

# Preparing MRS4719 Stock Solution for Cell Culture: Application Notes and Protocols

**Author:** BenchChem Technical Support Team. **Date:** April 2026

## Compound of Interest

Compound Name: MRS4719  
Cat. No.: B12398848

[Get Quote](#)

For Researchers, Scientists, and Drug Development Professionals

## Abstract

This document provides detailed application notes and protocols for the preparation and use of **MRS4719**, a potent and selective P2X4 receptor antagonist, in cell culture applications. **MRS4719** has demonstrated significant neuroprotective and neuro-rehabilitative activities, making it a valuable tool for research in areas such as ischemic stroke.<sup>[1][2]</sup> These guidelines will ensure accurate and reproducible experimental results when working with this compound.

## Introduction to MRS4719

**MRS4719** is a powerful antagonist of the P2X4 receptor, a ligand-gated ion channel activated by extracellular adenosine triphosphate (ATP).<sup>[3][4]</sup> It has an IC<sub>50</sub> value of 0.503  $\mu$ M for the human P2X4 receptor.<sup>[2][3][5][6]</sup> Research has shown that **MRS4719** can reduce infarct volume and brain atrophy in ischemic stroke models.<sup>[2][3][5]</sup> Furthermore, it inhibits ATP-induced calcium influx in primary human monocyte-derived macrophages.<sup>[1][2][3]</sup> These properties make **MRS4719** a compound of interest for studying the role of P2X4 receptors in various physiological and pathological processes.

## Chemical and Physical Properties

A summary of the key quantitative data for **MRS4719** is presented in the table below for easy reference.

Property	Value	Source
Molecular Formula	C <sub>26</sub> H <sub>13</sub> N <sub>5</sub> O <sub>3</sub> S.C <sub>6</sub> H <sub>15</sub> N	[1]
Molecular Weight	504.6 g/mol	[1][7]
IC50 (human P2X4R)	0.503 μM	[1][2][3][5][6][8]
Appearance	Powder	[1]
Purity	>98%	[7]

## Experimental Protocols

### Materials

- **MRS4719** powder
- Dimethyl sulfoxide (DMSO), cell culture grade
- Sterile microcentrifuge tubes
- Sterile, pyrogen-free water or phosphate-buffered saline (PBS)
- Pipettes and sterile, filtered pipette tips
- Vortex mixer
- Cell culture medium appropriate for the cell line being used

### Preparation of **MRS4719** Stock Solution (10 mM)

This protocol describes the preparation of a 10 mM stock solution of **MRS4719** in DMSO.

- Aseptic Technique: Perform all steps in a sterile environment, such as a laminar flow hood, to maintain the sterility of the stock solution.

- **Weighing the Compound:** Carefully weigh out the required amount of **MRS4719** powder. For example, to prepare 1 mL of a 10 mM stock solution, weigh out 0.5046 mg of **MRS4719** (Molecular Weight = 504.6 g/mol ).
- **Dissolving in DMSO:** Add the appropriate volume of DMSO to the weighed **MRS4719** powder. For the example above, add 100  $\mu$ L of DMSO to the 0.5046 mg of **MRS4719**.
- **Ensuring Complete Dissolution:** Vortex the solution thoroughly until the **MRS4719** powder is completely dissolved. Gentle warming (e.g., in a 37°C water bath) may be used to aid dissolution if necessary. Visually inspect the solution to ensure there are no visible particles.
- **Aliquoting and Storage:** Aliquot the stock solution into smaller, single-use volumes in sterile microcentrifuge tubes. This prevents repeated freeze-thaw cycles which can degrade the compound. Store the aliquots under the following conditions:
  - Long-term storage: -80°C for up to 6 months.[1]
  - Short-term storage: 4°C for up to 2 weeks.[1]
  - The powder form can be stored at -20°C for up to 2 years.[1]

## Preparation of Working Solutions

For cell culture experiments, the concentrated DMSO stock solution must be diluted to the final working concentration in the cell culture medium. Typical working concentrations for in vitro studies range from 0.1  $\mu$ M to 3.0  $\mu$ M.[2]

- **Thawing the Stock Solution:** Thaw a single aliquot of the 10 mM **MRS4719** stock solution at room temperature.
- **Serial Dilution:** Perform a serial dilution of the stock solution in cell culture medium to achieve the desired final concentration. It is crucial to add the **MRS4719** solution to the medium and mix immediately to avoid precipitation.
  - Example for a 1  $\mu$ M working solution:
    - Prepare an intermediate dilution by adding 1  $\mu$ L of the 10 mM stock solution to 999  $\mu$ L of cell culture medium to get a 10  $\mu$ M solution.

- Add 100  $\mu\text{L}$  of the 10  $\mu\text{M}$  intermediate solution to 900  $\mu\text{L}$  of cell culture medium to achieve a final concentration of 1  $\mu\text{M}$ .
- Vehicle Control: It is essential to include a vehicle control in your experiments. This control should contain the same final concentration of DMSO as the experimental conditions to account for any effects of the solvent on the cells.

## Signaling Pathway and Experimental Workflow

The following diagrams illustrate the mechanism of action of **MRS4719** and a typical experimental workflow for its use in cell culture.

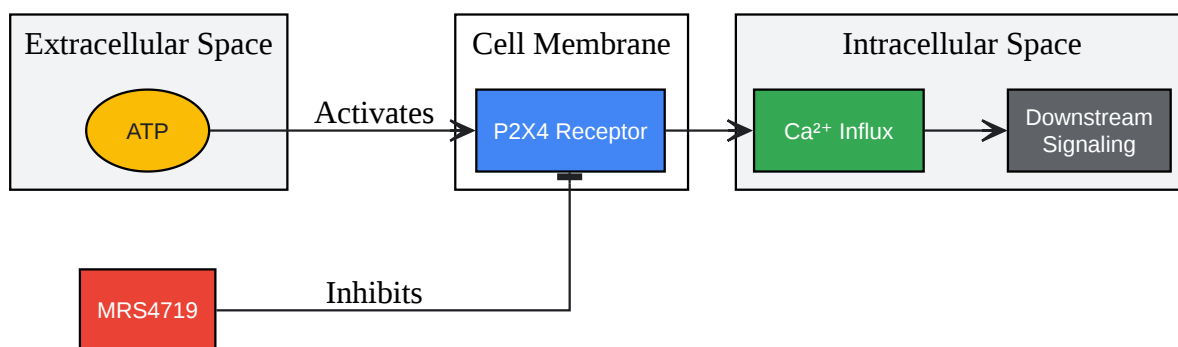

[Click to download full resolution via product page](#)

Caption: Mechanism of action of **MRS4719** as a P2X4 receptor antagonist.

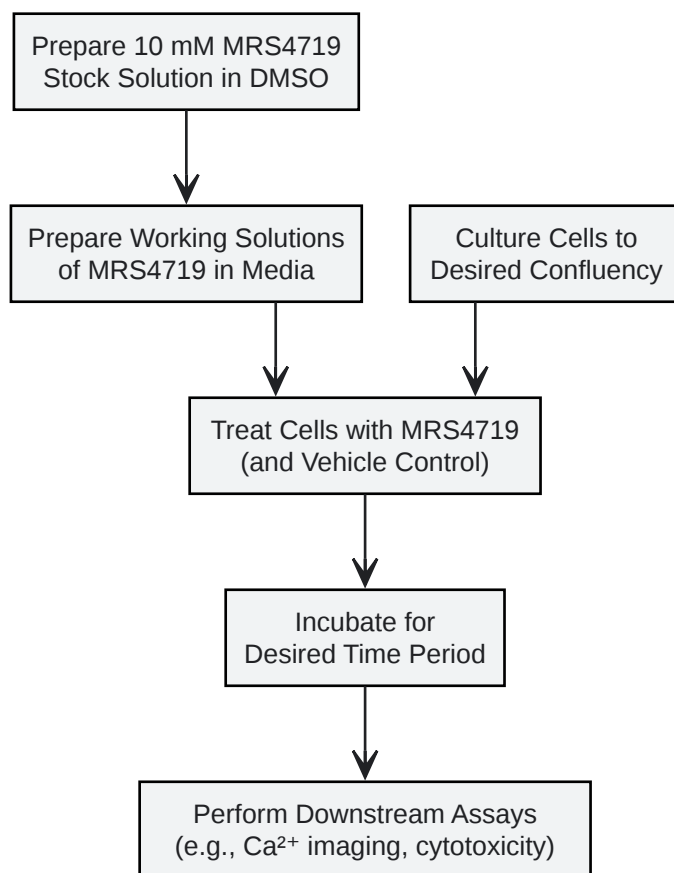

[Click to download full resolution via product page](#)

Caption: General experimental workflow for using **MRS4719** in cell culture.

### Need Custom Synthesis?

BenchChem offers custom synthesis for rare earth carbides and specific isotopic labeling.

Email: [info@benchchem.com](mailto:info@benchchem.com) or [Request Quote Online](#).

## References

- 1. [MRS4719 Datasheet DC Chemicals \[dcchemicals.com\]](#)
- 2. [medchemexpress.com \[medchemexpress.com\]](#)
- 3. [Structure–Activity Relationship and Neuroprotective Activity of 1,5-Dihydro-2H-naphtho\[1,2-b\]\[1,4\]diazepine-2,4\(3H\)-diones as P2X4 Receptor Antagonists - PMC \[pmc.ncbi.nlm.nih.gov\]](#)

- [4. researchgate.net \[researchgate.net\]](https://www.researchgate.net)
- [5. pubs.acs.org \[pubs.acs.org\]](https://pubs.acs.org)
- [6. Structure-Activity Relationship and Neuroprotective Activity of 1,5-Dihydro-2 H-naphtho\[1,2- b\]\[1,4\]diazepine-2,4\(3 H\)-diones as P2X4 Receptor Antagonists - PubMed \[pubmed.ncbi.nlm.nih.gov\]](#)
- [7. medkoo.com \[medkoo.com\]](https://www.medkoo.com)
- [8. ahajournals.org \[ahajournals.org\]](https://www.ahajournals.org)
- To cite this document: BenchChem. [Preparing MRS4719 Stock Solution for Cell Culture: Application Notes and Protocols]. BenchChem, [2026]. [Online PDF]. Available at: [\[https://www.benchchem.com/product/b12398848/docs#preparing-mrs4719-stock-solution-for-cell-culture-application-notes-and-protocols\]](https://www.benchchem.com/product/b12398848/docs#preparing-mrs4719-stock-solution-for-cell-culture-application-notes-and-protocols)

---

#### Disclaimer & Data Validity:

The information provided in this document is for Research Use Only (RUO) and is strictly not intended for diagnostic or therapeutic procedures. While BenchChem strives to provide accurate protocols, we make no warranties, express or implied, regarding the fitness of this product for every specific experimental setup.

**Technical Support:** The protocols provided are for reference purposes. Unsure if this reagent suits your experiment?

**Need Industrial/Bulk Grade?** [Request Custom Synthesis Quote](#)

## BenchChem

Our mission is to be the trusted global source of essential and advanced chemicals, empowering scientists and researchers to drive progress in science and industry.

#### Contact

Address: 3281 E Guasti Rd  
Ontario, CA 91761, United States  
Phone: (601) 213-4426  
Email: [info@benchchem.com](mailto:info@benchchem.com)

Contact our Ph.D. Support Team for a compatibility check