

# Optimizing Pomalidomide-Based PROTACs: A Comparative Analysis of Linker Length

**Author:** BenchChem Technical Support Team. **Date:** April 2026

## Compound of Interest

Compound Name: Pomalidomide-C11-NH2

Cat. No.: B12398348

[Get Quote](#)

A deep dive into the critical role of linker length in the efficacy of Pomalidomide-based Proteolysis Targeting Chimeras (PROTACs), this guide provides researchers, scientists, and drug development professionals with a comparative analysis supported by experimental data. The selection of an appropriate linker is a crucial determinant of a PROTAC's success, influencing its ability to form a stable and productive ternary complex between the target protein and the Cereblon (CRBN) E3 ligase.

Pomalidomide, a potent ligand for the CRBN E3 ubiquitin ligase, is a cornerstone in the design of PROTACs. These heterobifunctional molecules tether a target protein to an E3 ligase, leading to the ubiquitination and subsequent degradation of the target. The linker, far from being a mere spacer, plays a pivotal role in this process. Its length and composition dictate the physicochemical properties, cell permeability, and the ultimate degradation efficiency of the PROTAC.

## The Decisive Impact of Linker Length on PROTAC Performance

The length of the linker is a parameter that necessitates meticulous optimization for each target protein. An optimal linker length is essential for bridging the distance between the E3 ligase

and the target protein, facilitating the formation of a stable ternary complex. A linker that is too short can result in steric hindrance, preventing the formation of a productive complex.

Conversely, an excessively long linker can lead to an entropically unfavorable complex and may induce the "hook effect," a phenomenon where high concentrations of the PROTAC lead to the formation of binary complexes with either the target protein or the E3 ligase, thereby diminishing degradation efficiency.

Experimental evidence underscores that the optimal linker length is highly dependent on the specific target protein. For instance, in the development of p38 $\alpha$  degraders, a minimum linker length of 15 atoms was found to be necessary for significant activity, with the optimal length being in the range of 16-17 atoms.

## Quantitative Analysis of Linker Length on PROTAC Efficacy

The following tables summarize quantitative data from published studies on Pomalidomide-based PROTACs, illustrating the impact of linker length on their degradation efficiency (DC50 and Dmax) and, where available, their anti-proliferative activity (IC50). It is important to note that direct comparisons across different targets and cell lines can be challenging due to variations in experimental conditions. However, these data provide valuable insights into the performance of different linker strategies.

**Table 1: Comparative Analysis of Linker Length on p38 $\alpha$  Degradation**

| PROTAC ID       | Linker Type | Linker Length (atoms) | DC50 (nM) in T47D cells    | DC50 (nM) in BBL358 cells |
|-----------------|-------------|-----------------------|----------------------------|---------------------------|
| NR-X (example)  | Alkyl/PEG   | < 15                  | Poor degradation           | Poor degradation          |
| NR-7h           | Alkyl/PEG   | 16                    | ~3-27                      | ~3-27                     |
| NR-6a           | Alkyl/PEG   | 17                    | ~3-27                      | ~3-27                     |
| NR-1c (example) | Alkyl/PEG   | 20                    | Less efficient degradation | Efficient degradation     |

Data compiled from studies on p38 $\alpha$  and p38 $\beta$  degraders.[\[1\]](#)[\[2\]](#)

## Table 2: General Observations on Linker Length for Other Targets

| Target Protein   | Linker Type | Optimal Linker Length (atoms) | Key Observations   |
|--|-------------|-------------------------------|--|
| Estrogen Receptor (ER)                                     | Alkyl       | 16                            | A 16-atom linker was found to be superior for ER-based PROTACs, leading to significant degradation and inhibition of cell proliferation.[3][4]   |
| Bromodomain and Extra-Terminal (BET) proteins (e.g., BRD4) | PEG         | Variable                      | While specific comparative data on linker length is dispersed, highly potent pomalidomide-based BET degraders like ARV-825 utilize PEG linkers. The optimal length is target and cell line dependent.[5] |

## Visualizing the PROTAC Mechanism and Experimental Workflow

To better understand the concepts discussed, the following diagrams illustrate the key signaling pathway, a typical experimental workflow for linker optimization, and the logical relationship of the "hook effect."

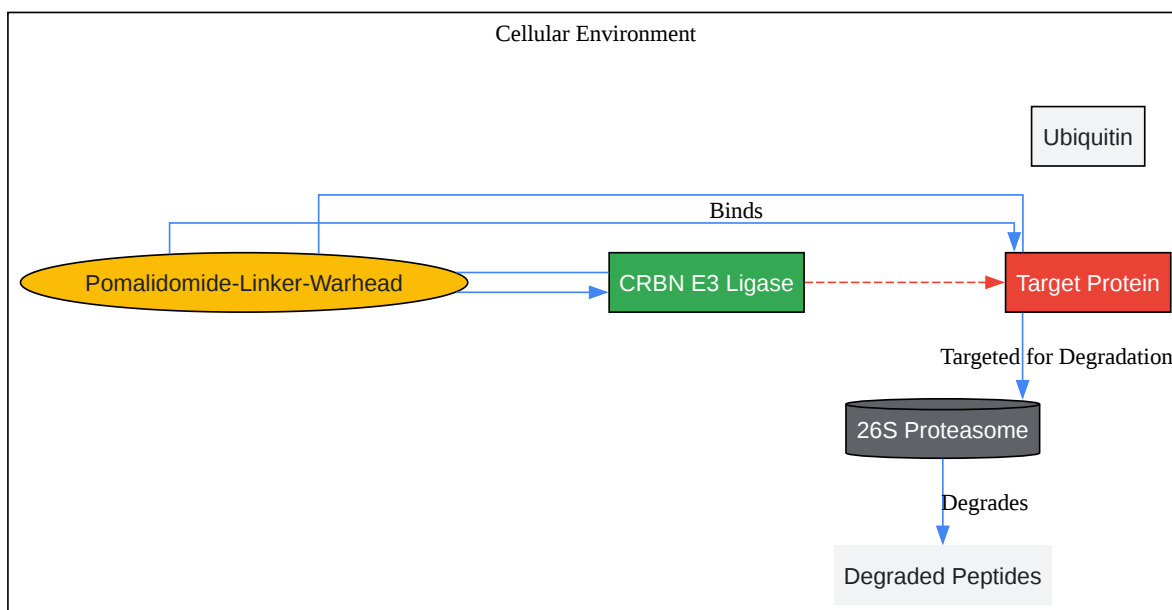

[Click to download full resolution via product page](#)

Caption: PROTAC-mediated protein degradation pathway.

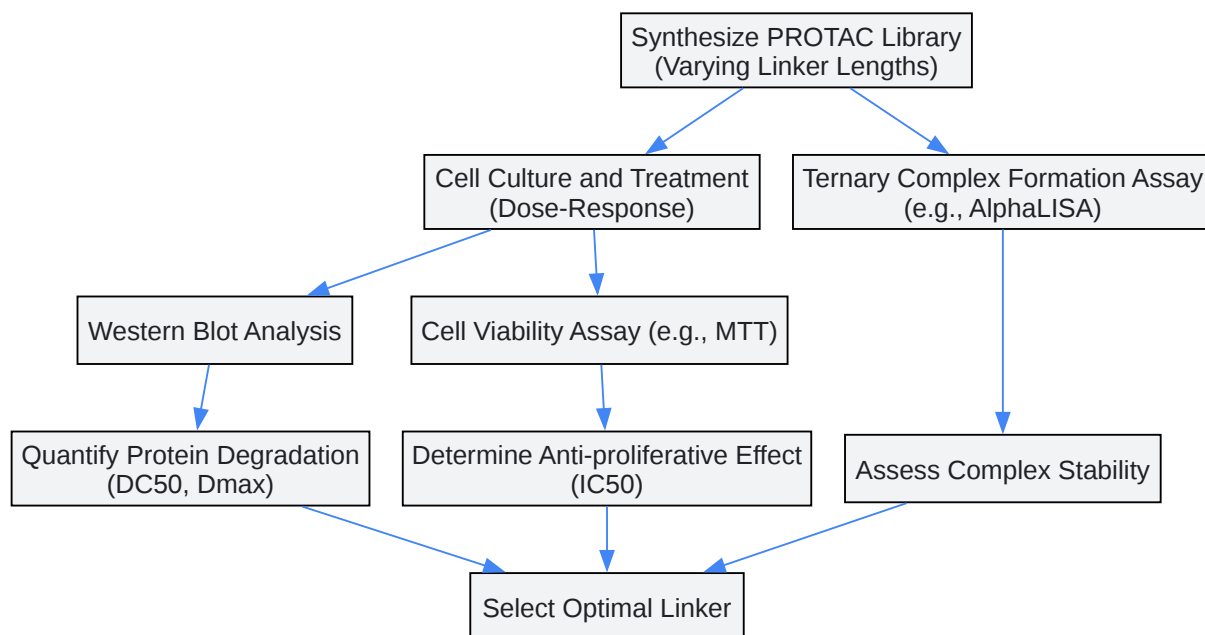

[Click to download full resolution via product page](#)

Caption: A typical workflow for assessing the degradation of a target protein by a PROTAC.

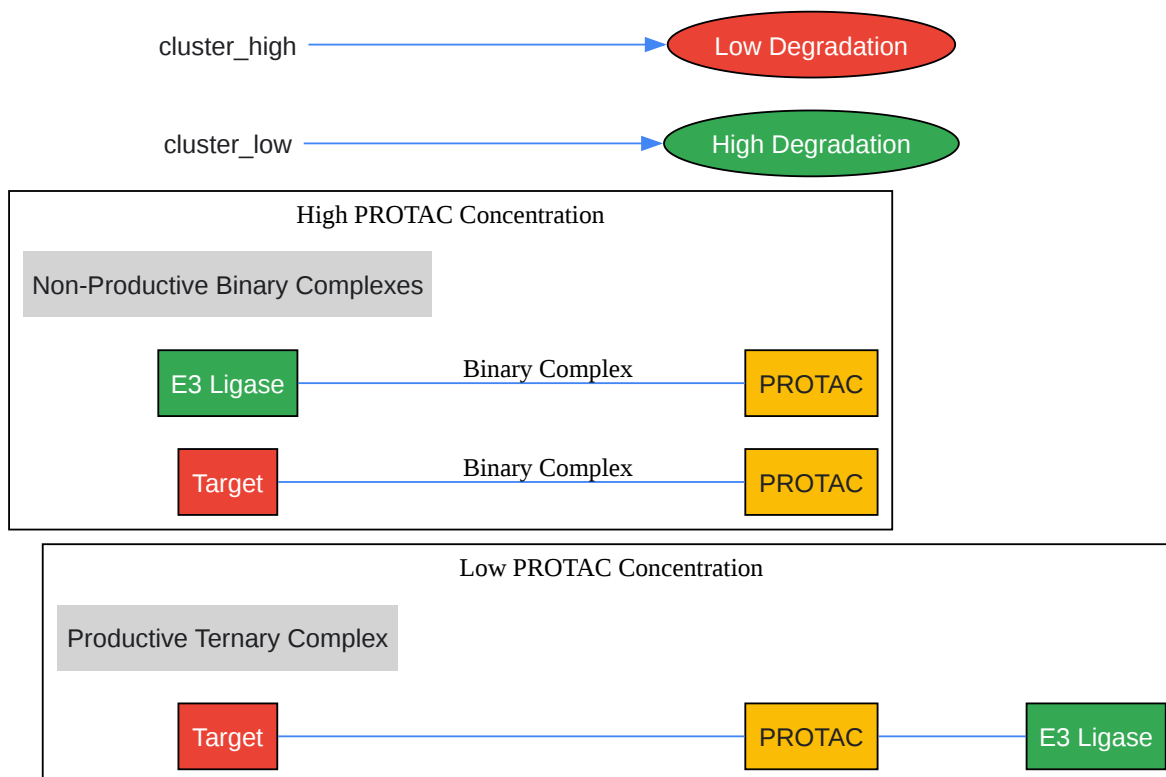

[Click to download full resolution via product page](#)

Caption: The "Hook Effect" in PROTAC-mediated degradation.

## Experimental Protocols

Detailed methodologies for the key experiments cited in this guide are provided below to enable researchers to evaluate their own Pomalidomide-based PROTACs.

### Western Blot for PROTAC-Induced Degradation

This protocol is a standard method to quantify the reduction in target protein levels following PROTAC treatment.

- **Cell Culture and Treatment:** Seed cells in 6-well plates and allow them to adhere overnight. Treat the cells with a serial dilution of the PROTAC for a specified duration (e.g., 24 hours). Include a vehicle control (e.g., DMSO).
- **Cell Lysis:** After treatment, wash the cells with ice-cold PBS and lyse them using RIPA buffer supplemented with protease and phosphatase inhibitors.
- **Protein Quantification:** Determine the protein concentration of each lysate using a BCA protein assay kit.
- **Sample Preparation and SDS-PAGE:** Normalize the protein concentrations for all samples. Add Laemmli sample buffer and boil at 95°C for 5-10 minutes. Load equal amounts of protein onto an SDS-PAGE gel and run the electrophoresis.
- **Protein Transfer:** Transfer the separated proteins from the gel to a PVDF or nitrocellulose membrane.
- **Immunoblotting:** Block the membrane with 5% non-fat milk or BSA in TBST for 1 hour at room temperature. Incubate the membrane with a primary antibody specific to the target protein overnight at 4°C. After washing, incubate with an HRP-conjugated secondary antibody for 1 hour at room temperature.
- **Detection and Analysis:** Visualize the protein bands using a chemiluminescence detection system. Quantify the band intensities using densitometry software. Normalize the target protein levels to a loading control (e.g., GAPDH or  $\beta$ -actin). Calculate the percentage of degradation relative to the vehicle-treated control to determine DC50 and Dmax values.

## AlphaLISA for Ternary Complex Formation

This assay is used to measure the formation of the ternary complex (Target Protein-PROTAC-E3 Ligase) in vitro.

- **Reagent Preparation:** Prepare tagged recombinant target protein (e.g., GST-tagged), tagged E3 ligase complex (e.g., His-tagged CRBN/DDB1), and the PROTAC at various concentrations in an appropriate assay buffer.

- **Assay Plate Setup:** In a 384-well plate, add the target protein, E3 ligase, and serially diluted PROTAC. Incubate at room temperature for 1 hour to allow for complex formation.
- **Bead Addition:** Add AlphaLISA acceptor beads (e.g., anti-GST) and donor beads (e.g., streptavidin-coated, if one protein is biotinylated) to the wells. Incubate in the dark at room temperature for 1 hour.
- **Signal Detection:** Read the plate on an AlphaLISA-compatible plate reader. The signal generated is proportional to the amount of ternary complex formed.
- **Data Analysis:** Plot the AlphaLISA signal against the PROTAC concentration. A bell-shaped curve is typically observed, and the peak of the curve indicates the concentration at which maximal ternary complex formation occurs. The decrease in signal at higher concentrations demonstrates the "hook effect."

## MTT Assay for Cell Viability

This colorimetric assay measures the metabolic activity of cells as an indicator of cell viability and proliferation following PROTAC treatment.

- **Cell Seeding:** Seed cells in a 96-well plate at a desired density and allow them to attach overnight.
- **PROTAC Treatment:** Treat the cells with a serial dilution of the PROTAC for a specified duration (e.g., 72 hours). Include a vehicle control.
- **MTT Addition:** Add MTT solution (3-(4,5-dimethylthiazol-2-yl)-2,5-diphenyltetrazolium bromide) to each well to a final concentration of 0.5 mg/mL and incubate for 3-4 hours at 37°C.
- **Formazan Solubilization:** Add a solubilization solution (e.g., DMSO or a solution of SDS in HCl) to each well to dissolve the formazan crystals.
- **Absorbance Measurement:** Measure the absorbance at a wavelength of 570 nm using a microplate reader.

- **Data Analysis:** Calculate the percentage of cell viability relative to the vehicle-treated control and plot the results to determine the IC50 value.

## Conclusion

The linker is a critical component in the design of effective Pomalidomide-based PROTACs. Its length must be carefully optimized for each target protein to ensure the formation of a stable and productive ternary complex, leading to efficient ubiquitination and degradation. While general trends suggest optimal linker lengths for certain protein families, empirical determination through systematic variation and evaluation using the described experimental protocols is paramount for the development of potent and selective protein degraders. This guide provides a framework for the rational design and evaluation of Pomalidomide-based PROTACs, emphasizing the crucial role of the linker in achieving therapeutic success.

### *Need Custom Synthesis?*

*BenchChem offers custom synthesis for rare earth carbides and specific isotopic labeling.*

*Email: [info@benchchem.com](mailto:info@benchchem.com) or [Request Quote Online](#).*

## References

- 1. DSpace [diposit.ub.edu]
- 2. Optimal linker length for small molecule PROTACs that selectively target p38 $\alpha$  and p38 $\beta$  for degradation - PubMed [pubmed.ncbi.nlm.nih.gov]
- 3. Activity of BET-proteolysis targeting chimeric (PROTAC) compounds in triple negative breast cancer - PMC [pmc.ncbi.nlm.nih.gov]
- 4. Current strategies for the design of PROTAC linkers: a critical review [explorationpub.com]
- 5. benchchem.com [benchchem.com]
- To cite this document: BenchChem. [Optimizing Pomalidomide-Based PROTACs: A Comparative Analysis of Linker Length]. BenchChem, [2026]. [Online PDF]. Available at: [https://www.benchchem.com/product/b12398348/docs#optimizing-pomalidomide-based-protacs-a-comparative-analysis-of-linker-length]

---

### Disclaimer & Data Validity:

The information provided in this document is for Research Use Only (RUO) and is strictly not intended for diagnostic or therapeutic procedures. While BenchChem strives to provide accurate protocols, we make no warranties, express or implied, regarding the fitness of this product for every specific experimental setup.

**Technical Support:** The protocols provided are for reference purposes. Unsure if this reagent suits your experiment?

**Need Industrial/Bulk Grade?** [Request Custom Synthesis Quote](#)

## BenchChem

Our mission is to be the trusted global source of essential and advanced chemicals, empowering scientists and researchers to drive progress in science and industry.

### Contact

Address: 3281 E Guasti Rd  
Ontario, CA 91761, United States  
Phone: (601) 213-4426  
Email: [info@benchchem.com](mailto:info@benchchem.com)

[Contact our Ph.D. Support Team for a compatibility check](#)