

# Comparative Technical Guide: $^{13}\text{C}3$ Lactate vs. $^{13}\text{C}$ Pyruvate Hyperpolarized MRI

**Author:** BenchChem Technical Support Team. **Date:** May 2026

## Compound of Interest

Compound Name: Sodium L-lactate- $^{13}\text{C}3$

Cat. No.: B12398467

[Get Quote](#)

## Executive Summary: The Sensitivity vs. Specificity Trade-off

In the field of dissolution Dynamic Nuclear Polarization (d-DNP),  $[1-^{13}\text{C}]$ Pyruvate remains the "gold standard" for sensitivity and robustness. It offers the highest Signal-to-Noise Ratio (SNR), the longest

relaxation times, and the most favorable transport kinetics across the Blood-Brain Barrier (BBB).

$[U-^{13}\text{C}]$ Lactate ( $^{13}\text{C}3$  Lactate) is a specialized probe. While it allows for the interrogation of "reverse" metabolic flux (Lactate

Pyruvate

TCA cycle) and isotopomer analysis, it suffers from significant sensitivity penalties due to J-coupling signal splitting and faster dipolar relaxation.

Verdict: Use  $[1-^{13}\text{C}]$ Pyruvate for detecting tumors and general metabolic deviations. Use  $[U-^{13}\text{C}]$ Lactate only when the specific scientific question requires proving reverse transport (e.g.,

MCT1/4 dynamics) or cardiac fuel preference, and be prepared for a 2-5x reduction in effective SNR.

## The Physics of Sensitivity: Why Pyruvate Wins

The sensitivity of a hyperpolarized probe is dictated by three factors: Polarization level (

), Relaxation rate (

), and Spectral dispersion (Splitting).

### Relaxation Kinetics ( )

The longevity of the hyperpolarized signal is critical.

- [1-13C]Pyruvate: The C1 carbonyl is a quaternary carbon with no directly attached protons. It has a very low Chemical Shift Anisotropy (CSA) at clinical field strengths (3T).

- Result:

seconds (in vivo).

- [U-13C]Lactate (13C3): The C1 is coupled to C2 and C3. The presence of adjacent 13C nuclei introduces 13C-13C dipolar relaxation, which significantly accelerates signal decay compared to singly labeled variants.

- Result:

seconds (estimated effective in vivo).

### Spectral Splitting (The Multiplet Penalty)

This is the most overlooked factor in sensitivity comparisons.

- [1-13C]Pyruvate: Appears as a singlet. All polarization energy is focused into a single spectral peak.

- [U-13C]Lactate: Due to scalar coupling (

Hz), the signal is split into multiplets (doublets/quartets).

- Impact: The signal amplitude is distributed across multiple peaks. Even if the integral is high, the peak height (which defines MRI detectability against noise) is reduced by factor of ~2-4x compared to a singlet.

## Data Comparison Table[1]

Feature	[1-13C]Pyruvate	[1-13C]Lactate	[U-13C]Lactate (13C3)
Primary Application	Glycolysis (Warburg Effect)	Cardiac Metabolism / Reverse Flux	Isotopomer Analysis / TCA Flux
In Vivo (3T)	40–60 s	~40–50 s	< 30 s (due to dipolar coupling)
Spectral Profile	Singlet (High SNR)	Singlet (High SNR)	Multiplet (Diluted SNR)
Endogenous Competition	Low (Pyruvate pool is small)	High (Lactate pool is large)	High
Downstream SNR	100% (Reference)	~52% (relative to Pyr)	< 25% (Estimated)

ngcontent-ng-c3932382896="" class="ng-star-inserted">

*Note on Data: Studies comparing [1-13C]Lactate to Pyruvate show a ~50% reduction in downstream metabolite SNR (e.g., Bicarbonate detection).[1] [U-13C]Lactate will be significantly lower due to the multiplet splitting described above.*

## Metabolic Utility & Pathway Mapping

While Pyruvate is sensitive, it only tells half the story (Forward Flux). Lactate is required to map the reverse transport.

## The Pool Size Dilution Problem

When you inject HP Pyruvate, it enters a cell where endogenous pyruvate is scarce (~50  $\mu\text{M}$ ). The HP signal dominates. When you inject HP Lactate, it enters a cell where endogenous lactate is abundant (1–10 mM). The HP label is instantly diluted by the "cold" pool, drastically reducing the apparent conversion rate (

) observable by MRI.

## Pathway Visualization (Graphviz)

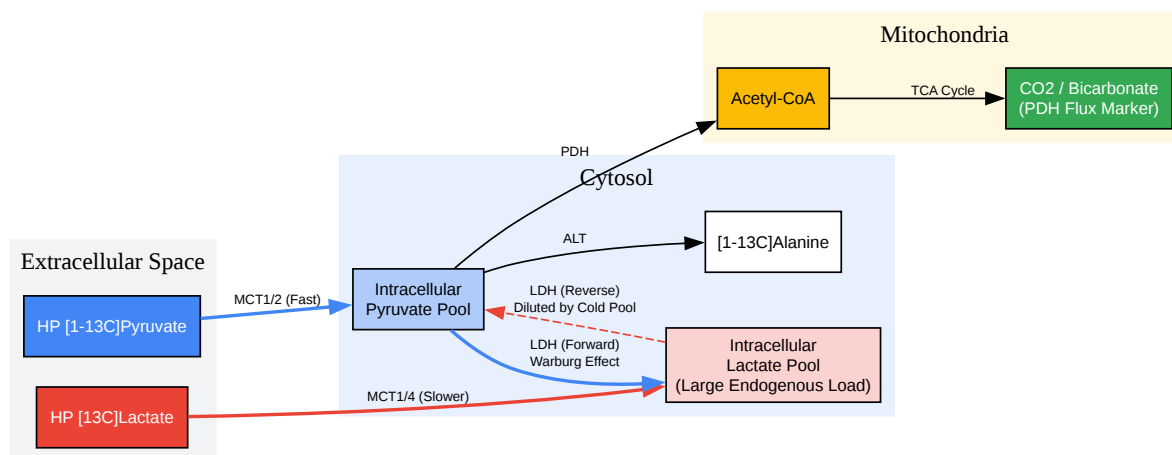

[Click to download full resolution via product page](#)

Figure 1: Comparison of metabolic entry points. Note that HP Lactate must traverse the large endogenous lactate pool (Red dashed line) before conversion to Pyruvate, causing signal dilution.

## Experimental Protocols

To ensure reproducibility, the formulation of the agent is as critical as the MRI sequence.

## Radical Choice & Polarization

- Pyruvate: Typically polarized neat (as Pyruvic Acid) with Trityl radical (AH111501).
- Lactate: Cannot be polarized as pure Lactic Acid easily (glassing issues). Usually requires a glassing agent (glycerol/glycol) or specific salt formulations (Sodium Lactate) in water/D<sub>2</sub>O.
  - Recommendation: Use [1-<sup>13</sup>C]Lactic Acid (syrup) mixed with small amounts of water and Trityl radical for optimal glass formation.

## Dissolution & Neutralization Workflow

Lactate solutions are often more acidic or require higher buffering capacity upon dissolution.

Step-by-Step Protocol:

- Sample Prep:
  - Mix 40 mg [1-<sup>13</sup>C]Lactic Acid with 15 mM Trityl Radical and 1.5 mM Gd<sup>3+</sup> (relaxation agent).
  - Critical: If using <sup>13</sup>C<sub>3</sub>, reduce Gd<sup>3+</sup> concentration to 1.0 mM to prevent excessive line broadening.
- Hyperpolarization:
  - Irradiate at 94 GHz (3.35 T) or 188 GHz (6.7 T) for 60–90 minutes.
  - Temp: 1.2 K.
- Dissolution:
  - Rapidly dissolve in superheated buffer (Tris/NaOH/EDTA).
  - Target pH: 7.4 ± 0.2. Warning: Lactate has a pK<sub>a</sub> of ~3.86. Ensure sufficient base equivalents.
- QC Injection:
  - Measure pH and Temperature.

- Inject within 15 seconds of dissolution to minimize

loss.

## DNP Workflow Visualization (Graphviz)

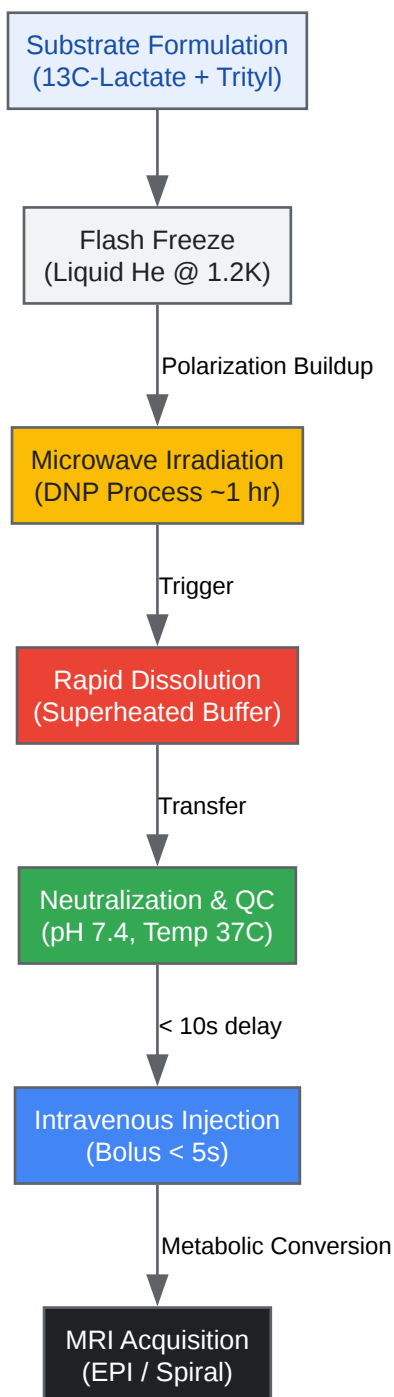

[Click to download full resolution via product page](#)

Figure 2: The critical time-sensitive workflow for Hyperpolarized MRI. Delays at the "Neutralize" or "Inject" stage are more punitive for Lactate due to shorter T1.

## References

- Lau, A. Z., et al. (2010). "Rapid multislice imaging of hyperpolarized  $^{13}\text{C}$  pyruvate and bicarbonate in the heart." *Magnetic Resonance in Medicine*.
- Chen, A. P., et al. (2008). "Feasibility of using hyperpolarized  $[1-^{13}\text{C}]$ lactate as a substrate for in vivo metabolic  $^{13}\text{C}$  MR imaging." *Magnetic Resonance Imaging*.
- Josan, S., et al. (2013). "Assessing cancer metabolism with hyperpolarized  $[1-^{13}\text{C}]$ lactate." *NMR in Biomedicine*. (Demonstrates the lower SNR of Lactate vs Pyruvate).[2][1][3]
- Cunningham, C. H., et al. (2016). "Hyperpolarized  $^{13}\text{C}$  Metabolic MRI of the Human Heart: Initial Experience." *Circulation Research*.
- Golman, K., et al. (2006). "Molecular imaging with endogenous substances." *Proceedings of the National Academy of Sciences*. (The foundational paper on Pyruvate DNP).

### Need Custom Synthesis?

BenchChem offers custom synthesis for rare earth carbides and specific isotopic labeling.

Email: [info@benchchem.com](mailto:info@benchchem.com) or [Request Quote Online](#).

## Sources

- 1. [biorxiv.org](https://www.biorxiv.org) [[biorxiv.org](https://www.biorxiv.org)]
- 2. [Cardiac metabolic imaging using hyperpolarized  \$\[1-^{13}\text{C}\]\$ lactate as a substrate | bioRxiv](#) [[biorxiv.org](https://www.biorxiv.org)]
- 3. [researchgate.net](https://www.researchgate.net) [[researchgate.net](https://www.researchgate.net)]
- To cite this document: BenchChem. [Comparative Technical Guide:  $^{13}\text{C}_3$  Lactate vs.  $^{13}\text{C}$  Pyruvate Hyperpolarized MRI]. BenchChem, [2026]. [Online PDF]. Available at: [<https://www.benchchem.com/product/b12398467/docs#comparative-technical-guide-13c3-lactate-vs-13c-pyruvate-hyperpolarized-mri>]

**Disclaimer & Data Validity:**

The information provided in this document is for Research Use Only (RUO) and is strictly not intended for diagnostic or therapeutic procedures. While BenchChem strives to provide accurate protocols, we make no warranties, express or implied, regarding the fitness of this product for every specific experimental setup.

**Technical Support:** The protocols provided are for reference purposes. Unsure if this reagent suits your experiment?

**Need Industrial/Bulk Grade?** [Request Custom Synthesis Quote](#)

## BenchChem

Our mission is to be the trusted global source of essential and advanced chemicals, empowering scientists and researchers to drive progress in science and industry.

### Contact

Address: 3281 E Guasti Rd  
Ontario, CA 91761, United States  
Phone: (601) 213-4426  
Email: [info@benchchem.com](mailto:info@benchchem.com)

[Contact our Ph.D. Support Team for a compatibility check](#)