

# Application of TRPV1 Activators in Pain Research Models: Application Notes and Protocols

**Author:** BenchChem Technical Support Team. **Date:** April 2026

## Compound of Interest

Compound Name: *TRPV1 activator-1*

Cat. No.: *B12398520*

[Get Quote](#)

For Researchers, Scientists, and Drug Development Professionals

## Introduction

The Transient Receptor Potential Vanilloid 1 (TRPV1), also known as the capsaicin receptor, is a critical ion channel involved in the detection and transduction of noxious stimuli.[1][2] Expressed predominantly in primary sensory neurons, TRPV1 acts as a polymodal sensor for heat, protons (acidic conditions), and a variety of endogenous and exogenous chemical ligands.[3][4][5] Its activation leads to a burning pain sensation, making it a key target in pain research and for the development of novel analgesics.

This document provides detailed application notes and protocols for the use of TRPV1 activators, such as capsaicin and resiniferatoxin (RTX), in various preclinical pain research models. These tools are invaluable for investigating the mechanisms of nociception and for the preclinical evaluation of analgesic drug candidates.

## Key TRPV1 Activators in Pain Research

The two most widely utilized TRPV1 activators in experimental settings are capsaicin, the pungent compound in chili peppers, and resiniferatoxin, a potent analog isolated from the plant *Euphorbia resinifera*.

- **Capsaicin:** The principal pungent component of chili peppers, capsaicin is a selective TRPV1 agonist. Its application initially causes a painful, burning sensation, followed by a period of desensitization, which can lead to long-lasting analgesia. This property is exploited in both preclinical research and clinical applications for pain relief.
- **Resiniferatoxin (RTX):** An ultrapotent capsaicin analog, RTX is several orders of magnitude more potent than capsaicin. Its high potency and ability to induce long-term desensitization and even ablation of TRPV1-expressing nerve fibers make it a powerful tool for studying nociceptive pathways and for potential therapeutic applications in severe, intractable pain.

## Signaling Pathway of TRPV1 Activation

Activation of the TRPV1 channel by agonists like capsaicin or by noxious heat leads to the influx of cations, primarily  $\text{Ca}^{2+}$  and  $\text{Na}^{+}$ , into the sensory neuron. This influx depolarizes the neuron, triggering the generation and propagation of action potentials to the central nervous system, which are ultimately perceived as pain. The sustained influx of  $\text{Ca}^{2+}$  also initiates various downstream signaling cascades.

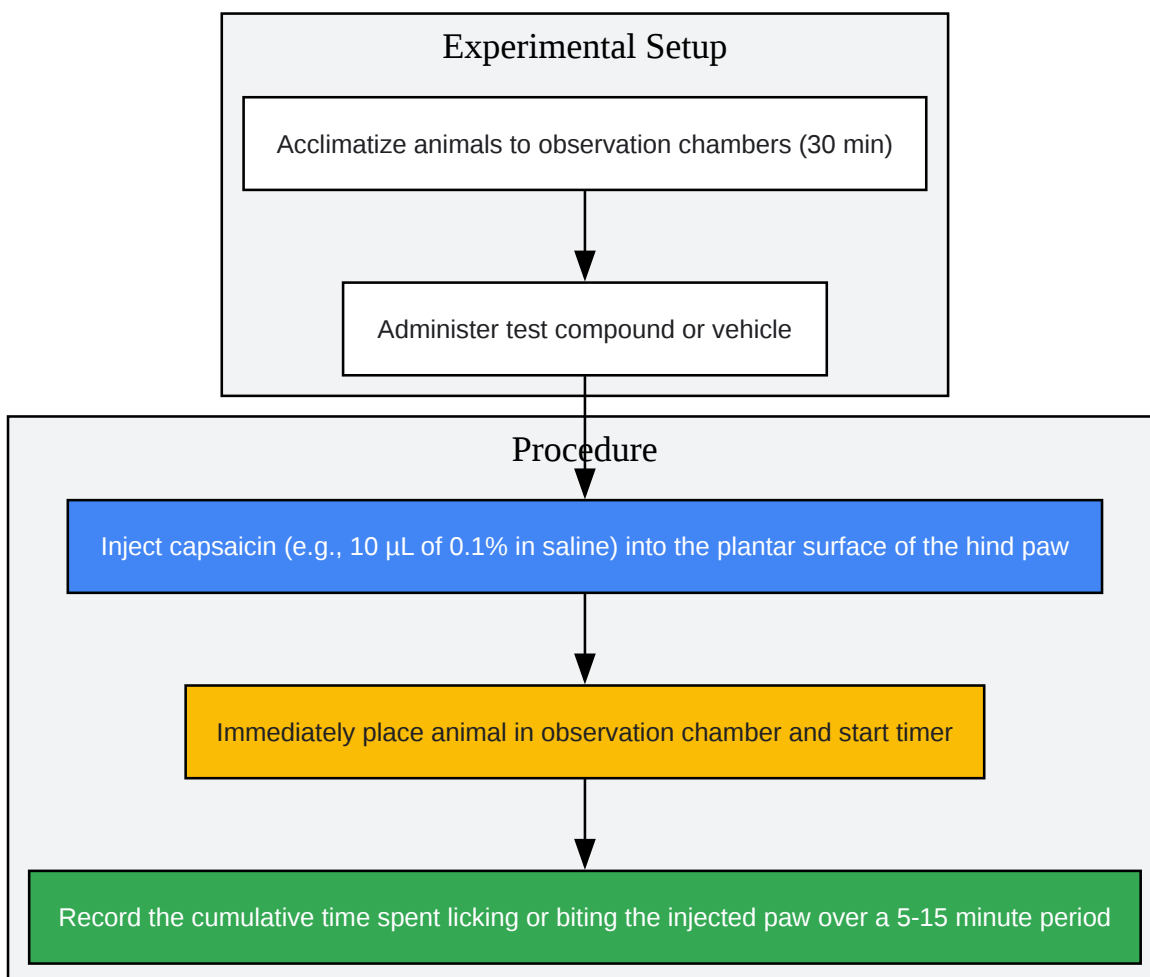
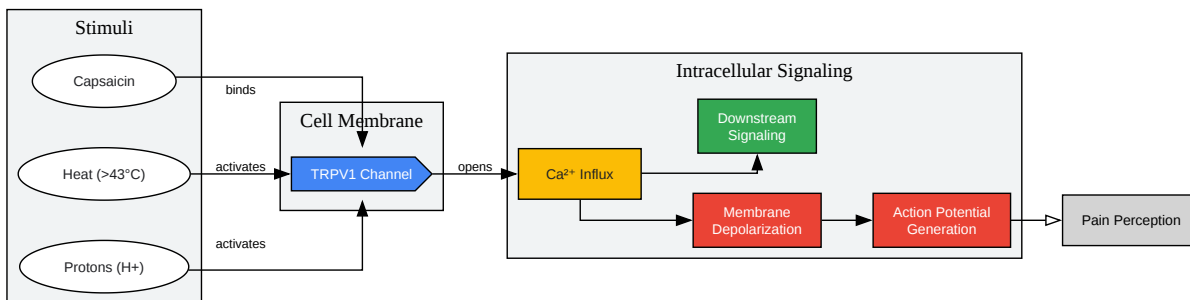

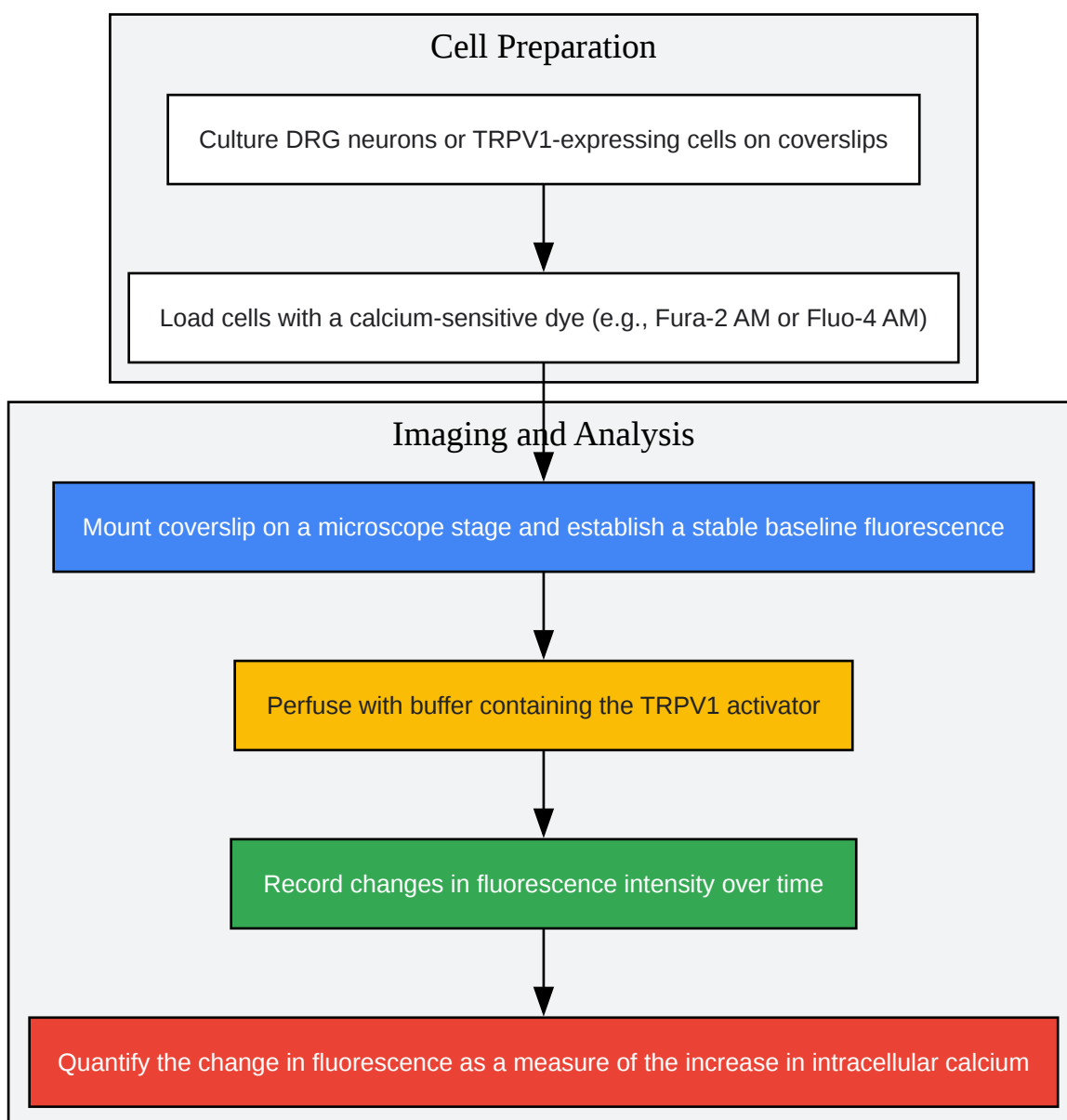

[Click to download full resolution via product page](#)

### Need Custom Synthesis?

BenchChem offers custom synthesis for rare earth carbides and specific isotopic labeling.

Email: [info@benchchem.com](mailto:info@benchchem.com) or [Request Quote Online](#).

## References

- [1. The TRPV1 receptor and nociception - PubMed \[pubmed.ncbi.nlm.nih.gov\]](#)
- [2. TRPV1-Targeted Drugs in Development for Human Pain Conditions - PubMed \[pubmed.ncbi.nlm.nih.gov\]](#)
- [3. TRPV1 Receptors and Signal Transduction - TRP Ion Channel Function in Sensory Transduction and Cellular Signaling Cascades - NCBI Bookshelf \[ncbi.nlm.nih.gov\]](#)
- [4. TRPV1 SUMOylation regulates nociceptive signaling in models of inflammatory pain - PMC \[pmc.ncbi.nlm.nih.gov\]](#)
- [5. Activation and activators of TRPV1 and their pharmaceutical implication - PubMed \[pubmed.ncbi.nlm.nih.gov\]](#)
- To cite this document: BenchChem. [Application of TRPV1 Activators in Pain Research Models: Application Notes and Protocols]. BenchChem, [2026]. [Online PDF]. Available at: [\[https://www.benchchem.com/product/b12398520/docs#application-of-trpv1-activators-in-pain-research-models-application-notes-and-protocols\]](https://www.benchchem.com/product/b12398520/docs#application-of-trpv1-activators-in-pain-research-models-application-notes-and-protocols)

---

#### Disclaimer & Data Validity:

The information provided in this document is for Research Use Only (RUO) and is strictly not intended for diagnostic or therapeutic procedures. While BenchChem strives to provide accurate protocols, we make no warranties, express or implied, regarding the fitness of this product for every specific experimental setup.

**Technical Support:** The protocols provided are for reference purposes. Unsure if this reagent suits your experiment?

**Need Industrial/Bulk Grade?** [Request Custom Synthesis Quote](#)

## BenchChem

Our mission is to be the trusted global source of essential and advanced chemicals, empowering scientists and researchers to drive progress in science and industry.

#### Contact

Address: 3281 E Guasti Rd

Ontario, CA 91761, United States

Phone: (601) 213-4426

Email: [info@benchchem.com](mailto:info@benchchem.com)

Contact our Ph.D. Support Team for a compatibility check