

Application Notes and Protocols for ONO-0740556 in Cell-Based Assays

Author: BenchChem Technical Support Team. **Date:** April 2026

Compound of Interest

Compound Name: ONO-0740556

Cat. No.: B12398866

[Get Quote](#)

For Researchers, Scientists, and Drug Development Professionals

Introduction

ONO-0740556 is a potent and selective synthetic agonist for the human Lysophosphatidic Acid Receptor 1 (LPA1), a G protein-coupled receptor (GPCR) involved in a myriad of physiological and pathological processes.[1][2][3] As an analog of lysophosphatidic acid (LPA), **ONO-0740556** exhibits significantly higher potency, making it a valuable tool for investigating LPA1 signaling and for the development of novel therapeutics targeting this receptor.[2] These application notes provide detailed protocols for utilizing **ONO-0740556** in common cell-based assays to characterize its activity and the downstream signaling pathways of LPA1.

Mechanism of Action

ONO-0740556 acts as a high-affinity agonist at the LPA1 receptor. Upon binding, it induces a conformational change in the receptor, leading to the activation of heterotrimeric G proteins. LPA1 is known to couple with multiple G protein subtypes, primarily Gai/o, Gαq/11, and Gα12/13.[3][4][5] Activation of these G proteins initiates a cascade of downstream signaling events, including the inhibition of adenylyl cyclase (via Gai/o), mobilization of intracellular calcium (via Gαq/11), and activation of the Rho signaling pathway (via Gα12/13).[3][4][5] These

signaling events ultimately regulate a wide range of cellular responses such as proliferation, migration, and survival.^{[4][5]}

Quantitative Data

The following table summarizes the key quantitative data for **ONO-0740556** in a relevant cell-based assay.

Parameter	Value	Cell Line	Assay Type	Reference
EC50	0.26 nM	Human LPA1 expressing cells	NanoBIT G-protein Dissociation Assay	^{[1][2][3]}

Note: EC50 (Half-maximal effective concentration) is the concentration of an agonist that induces a response halfway between the baseline and maximum response. A lower EC50 value indicates a higher potency.

Signaling Pathway Diagram

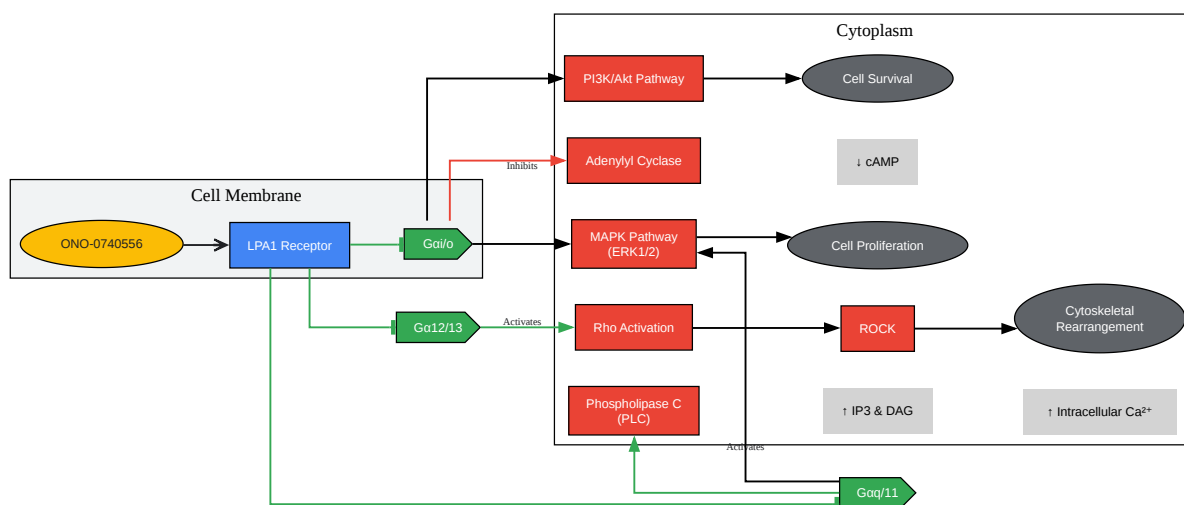

[Click to download full resolution via product page](#)

Caption: LPA1 Signaling Pathway Activated by **ONO-0740556**.

Experimental Protocols

Recommended Cell Lines

- HEK293 (Human Embryonic Kidney) cells: These cells are widely used for GPCR studies as they have low endogenous LPA1 expression and are easily transfectable for overexpression studies.
- CHO (Chinese Hamster Ovary) cells: Similar to HEK293 cells, CHO cells are a common host for stably or transiently expressing GPCRs.

- Cell lines with endogenous LPA1 expression: For studying LPA1 in a more physiologically relevant context, cell lines such as the human colon carcinoma cell line DLD1 can be used.

Protocol 1: NanoBiT® G-protein Dissociation Assay

This assay quantifies the activation of G proteins by LPA1 in real-time in live cells. The dissociation of the G α subunit from the G $\beta\gamma$ dimer upon receptor activation is measured using NanoLuc® Binary Technology (NanoBiT®).

Experimental Workflow Diagram

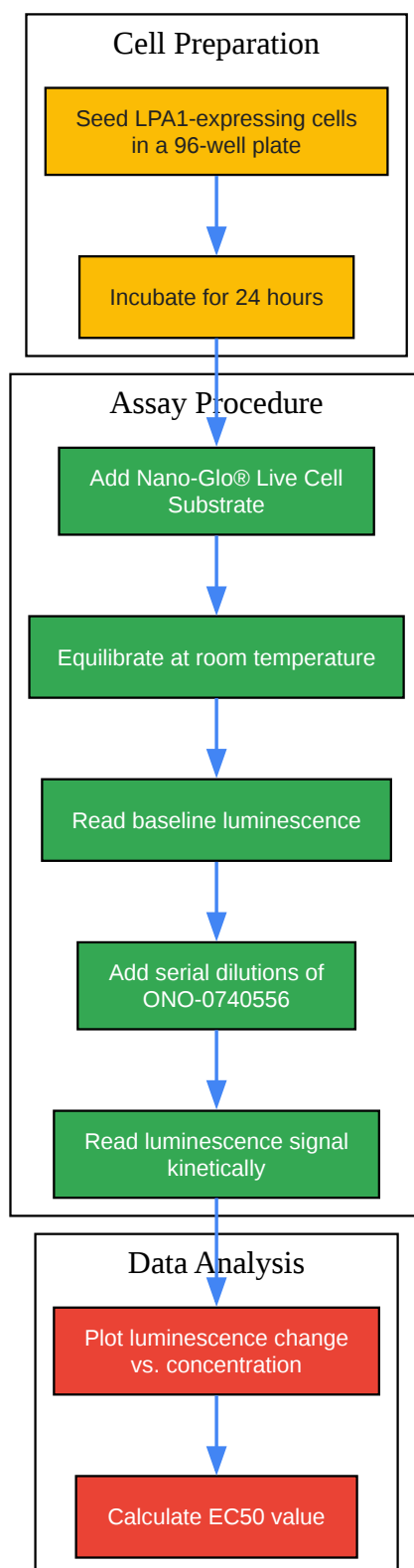

[Click to download full resolution via product page](#)

Caption: Workflow for the NanoBIT® G-protein Dissociation Assay.

Materials

- LPA1-expressing cells (e.g., HEK293 or CHO) co-expressing LgBiT-tagged G α and SmBiT-tagged G γ subunits.
- White, opaque 96-well cell culture plates.
- Cell culture medium (e.g., DMEM with 10% FBS).
- **ONO-0740556** stock solution (e.g., 10 mM in DMSO).
- Nano-Glo® Live Cell Assay System (Promega).
- Luminometer plate reader.

Procedure

- **Cell Seeding:** Seed the LPA1- and NanoBiT® G protein-expressing cells in a white, opaque 96-well plate at a density that will result in 80-90% confluency on the day of the assay. Incubate at 37°C and 5% CO₂ for 24 hours.
- **Reagent Preparation:** Prepare the Nano-Glo® Live Cell Substrate according to the manufacturer's instructions. Prepare serial dilutions of **ONO-0740556** in an appropriate assay buffer (e.g., HBSS with 20 mM HEPES).
- **Assay:** a. Carefully remove the growth medium from the cells. b. Add 80 μ L of the prepared Nano-Glo® Live Cell Substrate to each well. c. Incubate the plate at room temperature for 10-15 minutes to allow for substrate equilibration. d. Measure the baseline luminescence using a plate reader. e. Add 20 μ L of the **ONO-0740556** serial dilutions to the respective wells. f. Immediately begin kinetic measurement of luminescence for 30-60 minutes.
- **Data Analysis:** a. For each concentration of **ONO-0740556**, calculate the change in luminescence from the baseline. b. Plot the change in luminescence against the logarithm of the **ONO-0740556** concentration. c. Fit the data to a four-parameter logistic equation to determine the EC₅₀ value.

Protocol 2: Calcium Mobilization Assay

This assay measures the increase in intracellular calcium concentration following the activation of the Gαq/11 pathway by LPA1.

Materials

- LPA1-expressing cells (e.g., HEK293 or CHO).
- Black-walled, clear-bottom 96-well or 384-well microplates.
- Calcium-sensitive fluorescent dye (e.g., Fluo-4 AM).
- Pluronic F-127.
- Assay buffer (e.g., HBSS with 20 mM HEPES).
- **ONO-0740556** stock solution.
- Fluorescence plate reader with an injection system.

Procedure

- **Cell Seeding:** Seed LPA1-expressing cells into black-walled, clear-bottom microplates and grow to a confluent monolayer.
- **Serum Starvation:** Prior to the assay, serum-starve the cells for 4-6 hours in serum-free medium to reduce background signaling.
- **Dye Loading:** a. Prepare a loading solution of the calcium indicator dye (e.g., 2-5 μM Fluo-4 AM) with 0.02% Pluronic F-127 in assay buffer. b. Remove the serum-free medium and add the dye loading solution to each well. c. Incubate the plate at 37°C for 45-60 minutes in the dark. d. Gently wash the cells twice with assay buffer to remove excess dye.
- **Calcium Measurement:** a. Place the microplate into the fluorescence plate reader. b. Establish a stable baseline fluorescence reading for each well. c. Using the instrument's injection system, add the desired concentration of **ONO-0740556** to the wells. d. Immediately begin recording the fluorescence intensity kinetically for at least 60-120 seconds to capture the peak calcium response.

- Data Analysis: a. Determine the peak fluorescence intensity for each well after the addition of **ONO-0740556**. b. Plot the peak fluorescence intensity against the logarithm of the **ONO-0740556** concentration. c. Fit the data to a sigmoidal dose-response curve to calculate the EC50.

Protocol 3: Cell Proliferation Assay

This assay assesses the effect of LPA1 activation by **ONO-0740556** on cell growth.

Materials

- LPA1-expressing cells (e.g., DLD1 or engineered HEK293/CHO cells).
- Clear 96-well cell culture plates.
- Cell culture medium.
- Serum-free or low-serum (0.1% FBS) medium for starvation.
- **ONO-0740556** stock solution.
- Cell proliferation detection reagent (e.g., MTS, WST-1, or CyQUANT®).
- Microplate reader.

Procedure

- Cell Seeding: Seed cells in a clear 96-well plate at a low density (e.g., 2,000-5,000 cells per well) and allow them to adhere overnight.
- Serum Starvation: a. Aspirate the growth medium and wash the cells once with sterile PBS. b. Replace the medium with serum-free or low-serum medium. c. Incubate the cells for 24 hours to synchronize them in a quiescent state.
- Stimulation: a. Prepare serial dilutions of **ONO-0740556** in serum-free or low-serum medium. b. Aspirate the starvation medium and add the medium containing the different concentrations of **ONO-0740556**. c. Incubate the cells for 24-72 hours, depending on the cell type's doubling time.

- Proliferation Measurement: a. At the end of the incubation period, add the cell proliferation detection reagent to each well according to the manufacturer's protocol. b. Incubate for the recommended time (typically 1-4 hours). c. Measure the absorbance or fluorescence using a microplate reader at the appropriate wavelength.
- Data Analysis: a. Subtract the background reading from all wells. b. Plot the absorbance/fluorescence values against the logarithm of the **ONO-0740556** concentration. c. Determine the concentration of **ONO-0740556** that stimulates cell proliferation.

Troubleshooting

- Low signal in NanoBiT® assay: Ensure optimal transfection efficiency and expression levels of the LPA1 receptor and NanoBiT® G protein subunits. Titrate the Nano-Glo® Live Cell Substrate concentration.
- High background in calcium assay: Ensure complete removal of serum during starvation. Optimize the dye loading time and concentration.
- No proliferative response: Confirm LPA1 expression and functionality in the chosen cell line. Optimize the serum starvation and stimulation times. Ensure the cell seeding density allows for proliferation to occur.

Conclusion

ONO-0740556 is a powerful research tool for elucidating the role of the LPA1 receptor in cellular signaling. The protocols provided herein offer a starting point for researchers to investigate the effects of this potent agonist in a variety of cell-based assays. Careful optimization of experimental conditions for specific cell lines and assay formats will ensure the generation of robust and reproducible data.

Need Custom Synthesis?

BenchChem offers custom synthesis for rare earth carbides and specific isotopic labeling.

Email: info@benchchem.com or [Request Quote Online](#).

References

- [1. Illuminating G-Protein-Coupling Selectivity of GPCRs - PMC \[pmc.ncbi.nlm.nih.gov\]](#)
- [2. researchgate.net \[researchgate.net\]](#)
- [3. LPA receptor signaling: pharmacology, physiology, and pathophysiology - PMC \[pmc.ncbi.nlm.nih.gov\]](#)
- [4. researchgate.net \[researchgate.net\]](#)
- [5. benchchem.com \[benchchem.com\]](#)
- To cite this document: BenchChem. [Application Notes and Protocols for ONO-0740556 in Cell-Based Assays]. BenchChem, [2026]. [Online PDF]. Available at: [\[https://www.benchchem.com/product/b12398866/docs#application-notes-and-protocols-for-ono-0740556-in-cell-based-assays\]](https://www.benchchem.com/product/b12398866/docs#application-notes-and-protocols-for-ono-0740556-in-cell-based-assays)

Disclaimer & Data Validity:

The information provided in this document is for Research Use Only (RUO) and is strictly not intended for diagnostic or therapeutic procedures. While BenchChem strives to provide accurate protocols, we make no warranties, express or implied, regarding the fitness of this product for every specific experimental setup.

Technical Support: The protocols provided are for reference purposes. Unsure if this reagent suits your experiment?

Need Industrial/Bulk Grade? [Request Custom Synthesis Quote](#)

BenchChem

Our mission is to be the trusted global source of essential and advanced chemicals, empowering scientists and researchers to drive progress in science and industry.

Contact

Address: 3281 E Guasti Rd
Ontario, CA 91761, United States
Phone: (601) 213-4426
Email: info@benchchem.com

Contact our Ph.D. Support Team for a compatibility check