

initial studies on ZFP36 knockout mouse models

Author: BenchChem Technical Support Team. **Date:** April 2026

Compound of Interest

Compound Name: ZG36
Cat. No.: B12397880

[Get Quote](#)

An In-Depth Technical Guide to Initial Studies on ZFP36 Knockout Mouse Models

Introduction

Zinc finger protein 36 (ZFP36), also known as Tristetraprolin (TTP), is a critical RNA-binding protein that plays a pivotal role in post-transcriptional gene regulation. It is the most studied member of a family that also includes ZFP36L1 and ZFP36L2, and in rodents, ZFP36L3.[1][2] These proteins function by binding to Adenylate-Uridylate-Rich Elements (AREs), which are specific sequences typically found in the 3'-untranslated regions (3' UTR) of messenger RNAs (mRNAs).[1][3] This binding event initiates the degradation of the target mRNA, effectively silencing gene expression at the post-transcriptional level.[4]

The primary function of the ZFP36 family is to control the expression of inflammatory and immune-related genes, most notably Tumor Necrosis Factor-alpha (TNF- α).[1] Given this central role, ZFP36 knockout (KO) mouse models have become indispensable tools for researchers and drug development professionals. These models have provided profound insights into the physiological consequences of dysregulated inflammatory responses and have helped elucidate the complex signaling networks governed by ZFP36. This guide summarizes the foundational findings from initial studies on various ZFP36 KO mouse models, presenting key quantitative data, experimental protocols, and the underlying molecular pathways.

The ZFP36-Mediated mRNA Decay Pathway

The core function of ZFP36 is to destabilize target mRNAs. This process is initiated when the tandem CCCH-type zinc finger domains of ZFP36 recognize and bind to AREs in the 3' UTR of a target mRNA.[1] Following binding, ZFP36 acts as a scaffold, recruiting the CCR4-NOT deadenylase complex.[1][4] This complex removes the poly(A) tail from the mRNA, which is the rate-limiting step in mRNA degradation.[4] The now-deadenylated mRNA is rapidly degraded by cellular exonucleases. This mechanism allows for a swift and precise downregulation of gene expression in response to cellular signals.

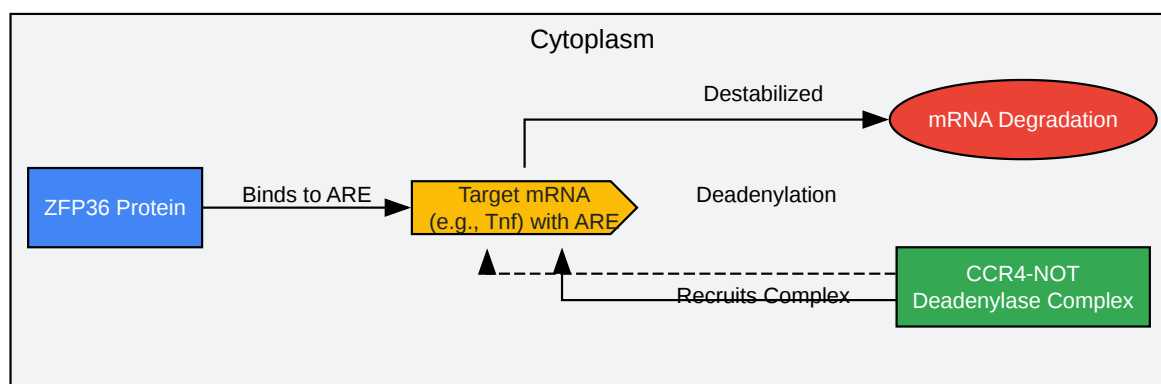

[Click to download full resolution via product page](#)

Diagram 1: The ZFP36-mediated mRNA decay pathway.

Phenotypes of ZFP36 Knockout Mouse Models

The consequences of ZFP36 deletion depend heavily on whether the gene is knocked out globally (germline) or in a specific cell lineage (conditional).

Germline ZFP36 Knockout

Initial studies on mice with a complete lack of ZFP36 revealed a severe and complex inflammatory syndrome.[1] This phenotype is primarily driven by the overexpression of TNF- α , as ZFP36 is its major negative regulator.[3] The key characteristics of these mice are summarized below.

Phenotypic Trait	Observation in ZFP36 KO Mice	Reference
Inflammatory Disease	Spontaneous development of inflammatory arthritis, dermatitis, and cachexia.	[1]
Autoimmunity	Presence of autoantibodies and signs of autoimmune disorders.	[1]
Myeloid Hyperplasia	Excessive proliferation of myeloid cells in the bone marrow.	[1]
TNF- α Levels	Markedly elevated systemic levels of TNF- α protein and mRNA.	[3]
Survival	Reduced lifespan due to severe inflammatory pathology.	[3][5]

Table 1: Summary of Phenotypes in Germline ZFP36 Knockout Mice.

Conditional Knockout Models

To dissect the cell-specific roles of ZFP36 and bypass the lethality of some germline knockouts, researchers have developed conditional KO models. These have revealed surprising and distinct functions in different immune and metabolic cell types.

Knockout Model	Key Phenotype	Key Quantitative Findings	Reference
Myeloid-Specific KO	Protection from diet-induced insulin resistance and hepatic steatosis.	Obese KO mice did not develop glucose intolerance seen in controls. Markedly improved lipid profiles.	[6]
T-Cell-Specific KO	Accelerated T-cell activation, proliferation, and enhanced anti-viral immunity.	Naïve KO CD4+ T cells showed greater proliferation than WT 16-24 hours post-activation. Enhanced clearance of LCMV infection.	[1][7]
T-Cell ZFP36L1/L2 dKO	Development of T-lymphoblastic leukemia (T-ALL).	Overexpression of the oncogenic transcription factor Notch1.	[3]
T-Cell ZFP36/L1/L2 TKO	Lethal, multiorgan inflammatory syndrome.	Median survival of approximately 10 weeks. Spontaneous T-cell activation and hypercytokinemia.	[5]

Table 2: Summary of Phenotypes in Conditional ZFP36 Family Knockout Mice.

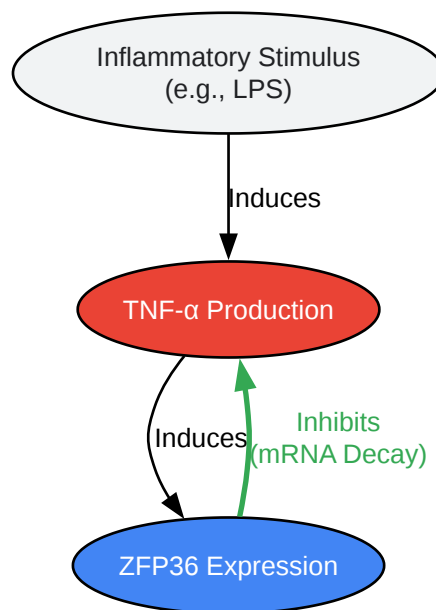
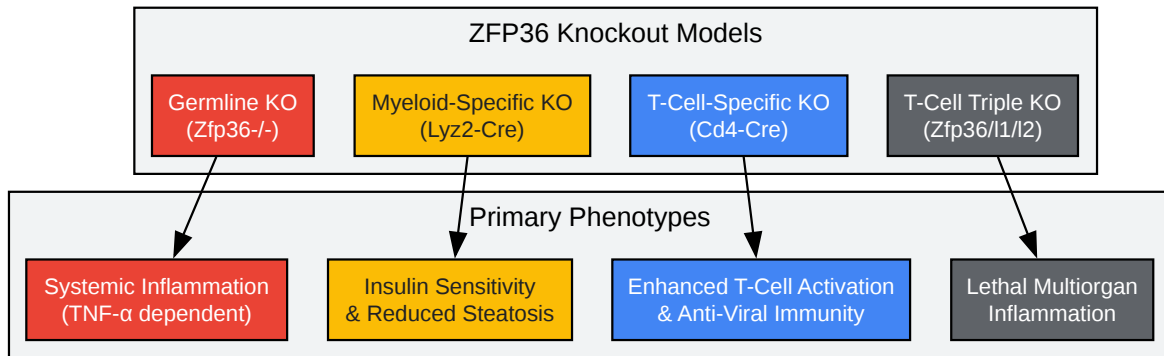

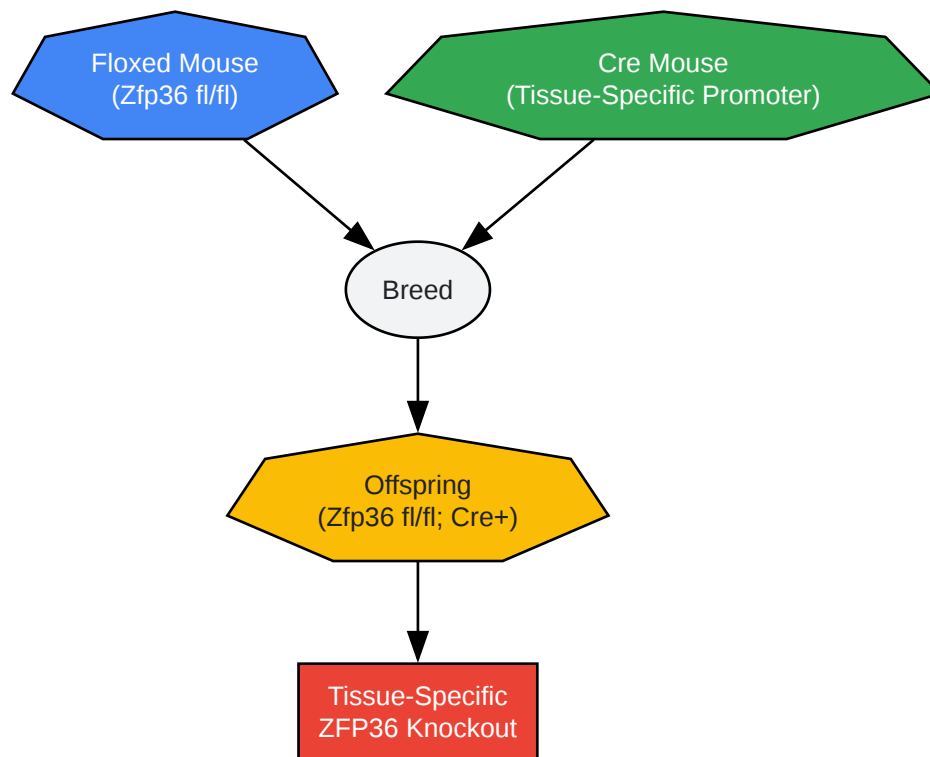

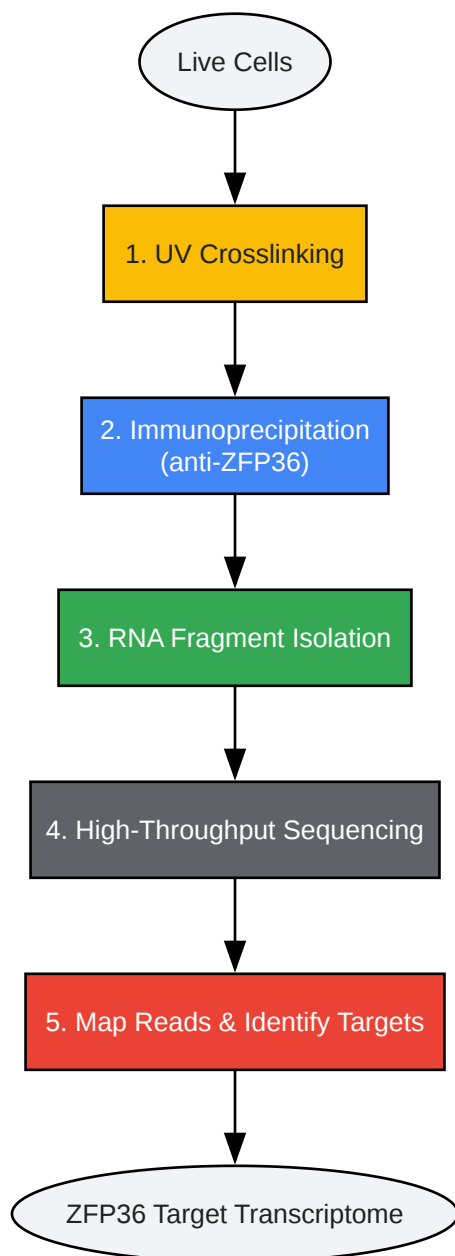

[Click to download full resolution via product page](#)

Need Custom Synthesis?

BenchChem offers custom synthesis for rare earth carbides and specific isotopic labeling.

Email: info@benchchem.com or [Request Quote Online](#).

References

- [1. Frontiers | Post-Transcriptional Regulation of Immune Responses and Inflammatory Diseases by RNA-Binding ZFP36 Family Proteins \[frontiersin.org\]](#)
- [2. Post-Transcriptional Regulation of Immune Responses and Inflammatory Diseases by RNA-Binding ZFP36 Family Proteins - PMC \[pmc.ncbi.nlm.nih.gov\]](#)
- [3. Deletion of the RNA-binding proteins Zfp36l1 and Zfp36l2 leads to perturbed thymic development and T-lymphoblastic leukaemia - PMC \[pmc.ncbi.nlm.nih.gov\]](#)
- [4. ZFP36-mediated mRNA decay regulates metabolism - PMC \[pmc.ncbi.nlm.nih.gov\]](#)
- [5. The ZFP36 family of RNA-binding proteins regulates homeostatic and autoreactive T cell responses - PMC \[pmc.ncbi.nlm.nih.gov\]](#)
- [6. journals.physiology.org \[journals.physiology.org\]](#)
- [7. ZFP36 RNA-binding proteins restrain T cell activation and anti-viral immunity - PMC \[pmc.ncbi.nlm.nih.gov\]](#)
- To cite this document: BenchChem. [initial studies on ZFP36 knockout mouse models]. BenchChem, [2026]. [Online PDF]. Available at: [\[https://www.benchchem.com/product/b12397880/docs#initial-studies-on-zfp36-knockout-mouse-models\]](https://www.benchchem.com/product/b12397880/docs#initial-studies-on-zfp36-knockout-mouse-models)

Disclaimer & Data Validity:

The information provided in this document is for Research Use Only (RUO) and is strictly not intended for diagnostic or therapeutic procedures. While BenchChem strives to provide accurate protocols, we make no warranties, express or implied, regarding the fitness of this product for every specific experimental setup.

Technical Support: The protocols provided are for reference purposes. Unsure if this reagent suits your experiment?

Need Industrial/Bulk Grade? [Request Custom Synthesis Quote](#)

BenchChem

Our mission is to be the trusted global source of essential and advanced chemicals, empowering scientists and researchers to drive progress in science and industry.

Contact

Address: 3281 E Guasti Rd

Ontario, CA 91761, United States

Phone: (601) 213-4426

Email: info@benchchem.com

[Contact our Ph.D. Support Team for a compatibility check](#)