

The Role of ZFP36 in Cellular Stress Responses: A Technical Guide

Author: BenchChem Technical Support Team. **Date:** April 2026

Compound of Interest

Compound Name: ZG36
Cat. No.: B12397880

[Get Quote](#)

Authored for: Researchers, Scientists, and Drug Development Professionals

Abstract

Zinc Finger Protein 36 (ZFP36), also known as Tristetraprolin (TTP), is a critical post-transcriptional regulator of gene expression. As an RNA-binding protein, it targets AU-rich elements (AREs) within the 3'-untranslated regions (3'-UTRs) of messenger RNAs (mRNAs), primarily those encoding proteins involved in cellular stress and inflammatory responses. By recruiting the CCR4-NOT deadenylase complex, ZFP36 orchestrates the rapid decay of these transcripts, functioning as a crucial brake on stress-induced gene expression. This guide provides an in-depth examination of the signaling pathways, molecular interactions, and quantitative effects of ZFP36's involvement in various cellular stress responses, including inflammatory, oxidative, and heat shock stress. Detailed experimental protocols and pathway visualizations are provided to facilitate further research and therapeutic development targeting this pivotal regulatory hub.

Core Mechanism of ZFP36-Mediated mRNA Decay

ZFP36 is a member of a highly conserved family of CCCH tandem zinc finger proteins that also includes ZFP36L1 and ZFP36L2.^{[1][2]} The primary function of these proteins is to bind to AREs

in the 3' UTR of target mRNAs.[3] This binding event serves as a scaffold for the recruitment of the CCR4-NOT deadenylase complex, which initiates the rate-limiting step of mRNA degradation: the removal of the poly(A) tail.[1][3][4] Once deadenylated, the mRNA is rapidly degraded by cellular exonucleases.[5] Under certain stress conditions, ZFP36 can also facilitate the transport of target mRNAs from stress granules, which are sites of translational arrest, to processing bodies (P-bodies), where mRNA decay occurs.[3]

ZFP36 in the Inflammatory Stress Response

The most well-characterized role of ZFP36 is its function as a negative regulator of inflammation.[4] Inflammatory stimuli, such as lipopolysaccharide (LPS) or cytokines like Interleukin-1 β (IL-1 β) and Tumor Necrosis Factor-alpha (TNF- α), trigger intracellular signaling cascades that lead to the production of potent pro-inflammatory mediators.[6] Many of the mRNAs encoding these mediators, including TNF- α , IL-6, and IL-8, contain AREs and are direct targets of ZFP36.[6]

The p38 MAPK/MK2 Regulatory Axis

A central pathway governing ZFP36 activity during inflammatory stress is the p38 MAPK cascade.[7][8]

- **Activation:** Stress signals like LPS activate the p38 MAPK pathway.[7]
- **Phosphorylation:** Activated p38 phosphorylates and activates its downstream kinase, MAPKAPK2 (MK2).[8][9]
- **Inactivation of ZFP36:** MK2 then phosphorylates ZFP36 at key serine residues (S52 and S178 in mice; S60 and S186 in humans).[3][9]
- **14-3-3 Binding:** This phosphorylation event creates a binding site for 14-3-3 adaptor proteins.[9] The formation of the ZFP36/14-3-3 complex inhibits ZFP36's deadenylase-recruiting activity, effectively stabilizing its target mRNAs (e.g., TNF- α) and allowing for a potent, transient inflammatory response.[3][9]
- **Negative Feedback:** The inflammatory response itself induces higher expression of ZFP36, creating a negative feedback loop that eventually resolves the inflammation by promoting the

decay of pro-inflammatory transcripts once the stress signal subsides and ZFP36 is dephosphorylated.[4][6]

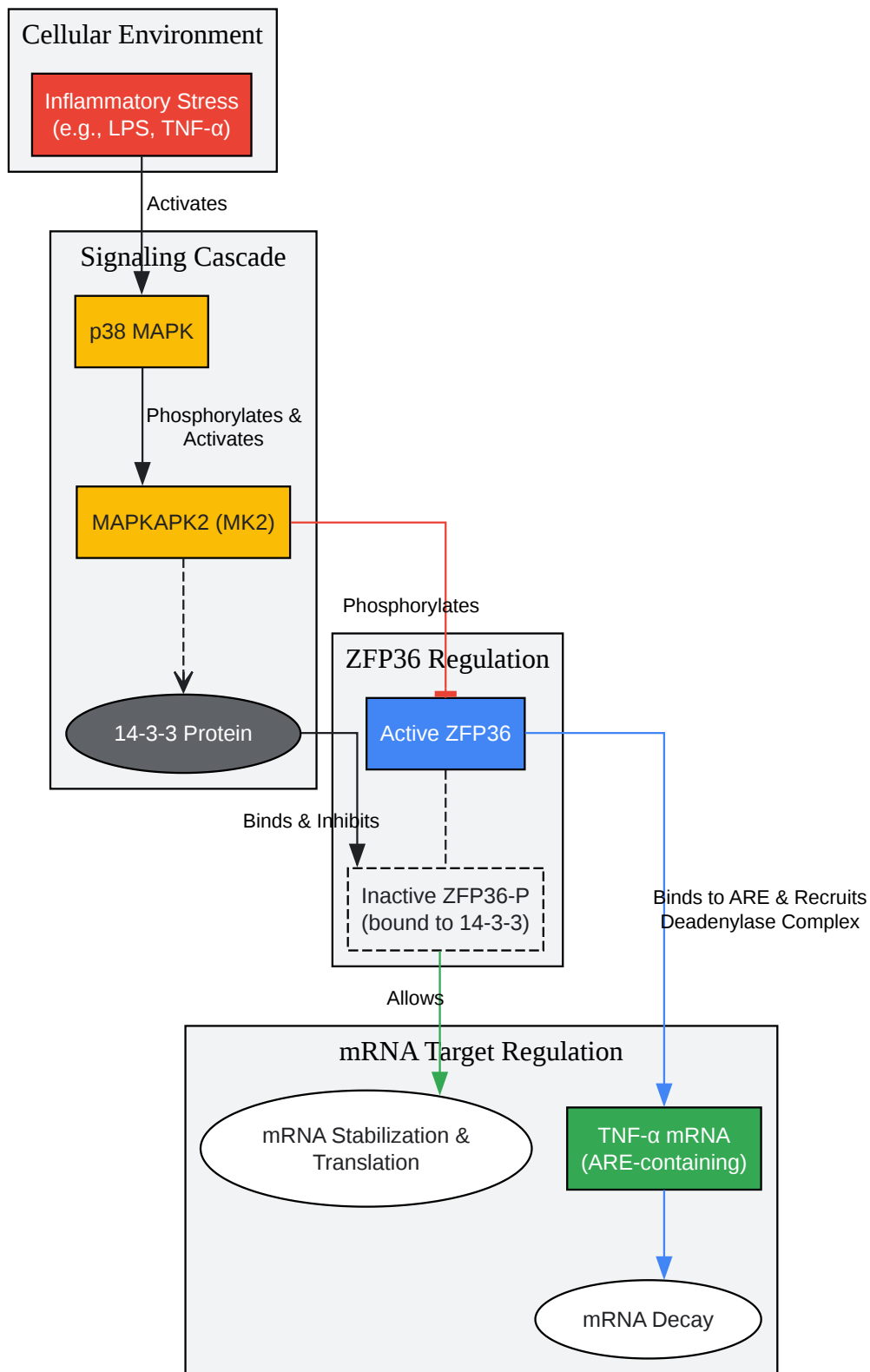

[Click to download full resolution via product page](#)**Figure 1.** The p38/MK2 pathway regulates ZFP36 activity.

Quantitative Data: ZFP36 and TNF- α mRNA Stability

The functional consequence of ZFP36 regulation is a dramatic change in the stability of its target mRNAs. This can be quantified by measuring mRNA half-life.

Cell Type	Condition	Target mRNA	mRNA Half-life (t $\frac{1}{2}$)	Citation
THP-1	Untreated	TNF- α	~17 minutes	[10]
THP-1	1 hr PMA stimulation	TNF- α	~36 minutes	[10]
THP-1	24 hr PMA (differentiation)	TNF- α	~21 minutes	[10]
A549	IL-1 β stimulation	TNF- α	~30-40 minutes	[6]
A549	IL-1 β stim. + ZFP36 siRNA	TNF- α	Significantly increased	[6]

ZFP36 in the Oxidative Stress Response

Oxidative stress, characterized by an excess of reactive oxygen species (ROS), can damage cellular components and trigger stress signaling. ZFP36 plays a protective role by regulating key enzymes involved in ROS production.

Regulation of NADPH Oxidase 4 (NOX4)

A key target of ZFP36 in the oxidative stress response is NADPH Oxidase 4 (NOX4), an enzyme that produces ROS.[11]

- Stress Induction: In neuronal cells, oxygen-glucose deprivation/reoxygenation (OGD/R), a model for ischemic injury, increases the expression of both ZFP36 and NOX4.[11]

- Direct Targeting: ZFP36 directly targets NOX4 mRNA for degradation by binding to AREs in its 3'-UTR.[11]
- Protective Effect: By promoting the decay of NOX4 mRNA, ZFP36 limits excessive ROS production, thereby protecting neurons from mitochondrial fragmentation and apoptosis.[11] Silencing ZFP36 exacerbates OGD/R-induced oxidative stress and cell death.[11]

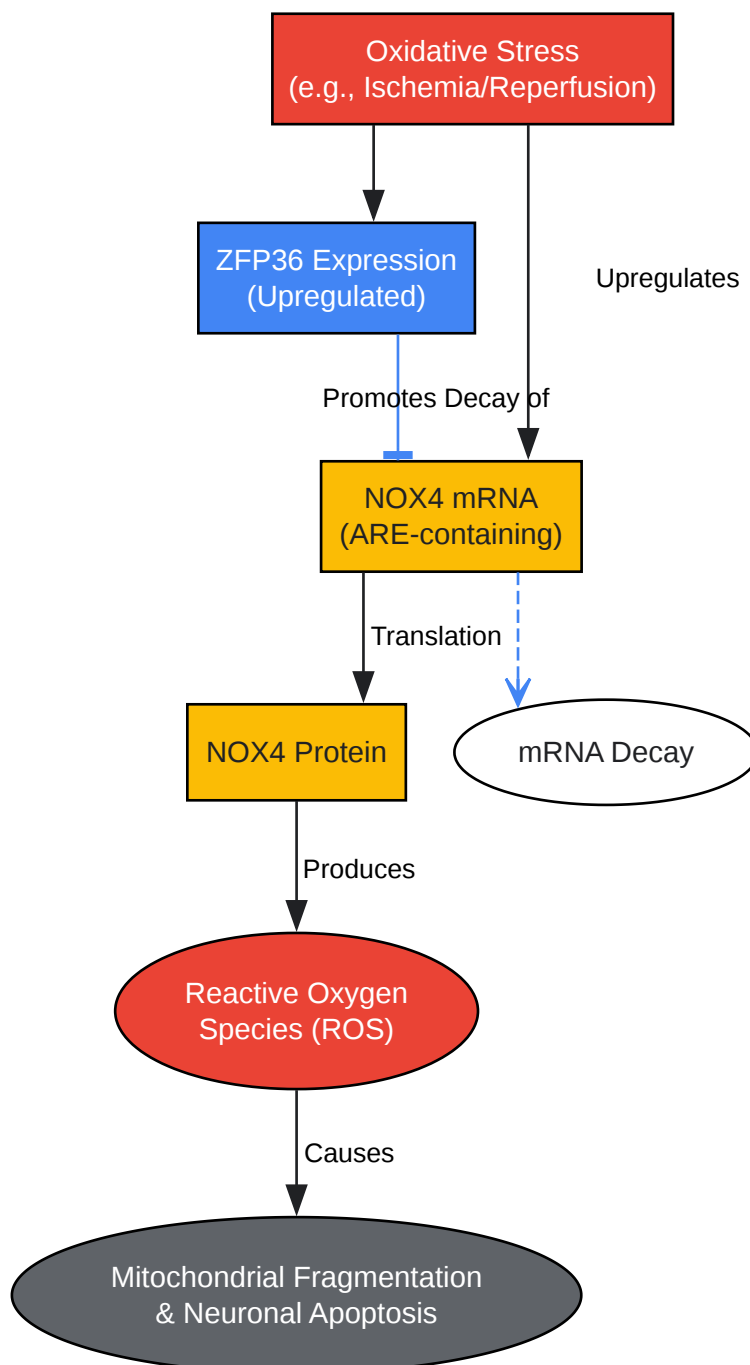

[Click to download full resolution via product page](#)

Figure 2. ZFP36 mitigates oxidative stress by targeting NOX4 mRNA.

ZFP36 Family in Other Stress Responses

Heat Shock Response

The heat shock response is a highly conserved cellular defense mechanism involving the upregulation of heat shock proteins (HSPs). The ZFP36 family member, ZFP36L1, has been implicated in regulating this pathway.

- Target: ZFP36L1 directly binds to the 3'-UTR of mRNAs encoding HSP70 family members, specifically HSPA1A and HSPA1B, to induce their decay.[12]
- Pathological Context: In the context of osteoarthritis, a disease involving mechanical and inflammatory stress, ZFP36L1 is upregulated in chondrocytes.[12] By destabilizing the normally protective HSPA1A/B mRNAs, elevated ZFP36L1 contributes to chondrocyte apoptosis and disease progression.[12] Genetic silencing of Zfp36l1 in mouse models abrogates experimental osteoarthritis, highlighting its therapeutic potential.[12]

DNA Damage Response

ZFP36 paralogs ZFP36L1 and ZFP36L2 play a crucial role as post-transcriptional safeguards against genomic instability by limiting DNA damage response signaling.[13] They act as critical regulators during lymphocyte development, where they control the expression of transcripts involved in the cell cycle and DNA damage response to ensure proper checkpoints are enforced.[13]

Key Experimental Methodologies

Protocol: mRNA Stability Assay via Actinomycin D Chase

This method measures the decay rate of a specific mRNA by halting transcription and quantifying the remaining mRNA over time.

Objective: To determine the half-life of a ZFP36 target mRNA (e.g., TNF- α).

Principle: Cells are treated with Actinomycin D, a potent inhibitor of RNA polymerase II. With new transcription blocked, the decay of the existing mRNA pool can be measured by collecting

samples at various time points and quantifying the transcript of interest using quantitative reverse transcription PCR (qRT-PCR).[14]

Procedure:

- Cell Culture: Plate cells (e.g., macrophages or A549 epithelial cells) to achieve 70-80% confluency on the day of the experiment.
- Stimulation: Treat cells with a stress-inducing agent (e.g., 100 ng/mL LPS for macrophages) for a predetermined time (e.g., 2 hours) to induce robust expression of the target mRNA.
- Transcription Inhibition: Add Actinomycin D to the culture medium at a final concentration of 5-10 µg/mL.[10] This is Time 0 (T=0).
- Time-Course Collection: Harvest cells at multiple time points after Actinomycin D addition (e.g., 0, 15, 30, 60, 90, 120 minutes).
- RNA Extraction: Immediately lyse cells at each time point using a suitable reagent (e.g., TRIzol) and purify total RNA according to the manufacturer's protocol. Ensure DNase treatment to remove genomic DNA contamination.
- cDNA Synthesis: Synthesize cDNA from 1 µg of total RNA using a reverse transcription kit with a mix of oligo(dT) and random hexamer primers.[14]
- qRT-PCR: Perform qRT-PCR using SYBR Green master mix and primers specific for the target mRNA (e.g., TNF-α) and a highly stable reference gene (e.g., 18S rRNA).
- Data Analysis:
 - Normalize the Ct value of the target gene to the reference gene for each time point ($\Delta Ct = Ct_{\text{target}} - Ct_{\text{reference}}$).
 - Calculate the amount of mRNA remaining relative to T=0 using the $2^{-\Delta\Delta Ct}$ method, where $\Delta\Delta Ct = \Delta Ct_{\text{timepoint}} - \Delta Ct_{T=0}$.
 - Plot the percentage of mRNA remaining versus time on a semi-logarithmic graph.

- Determine the half-life ($t_{1/2}$) as the time it takes for the mRNA level to decrease to 50% of its initial value at T=0.

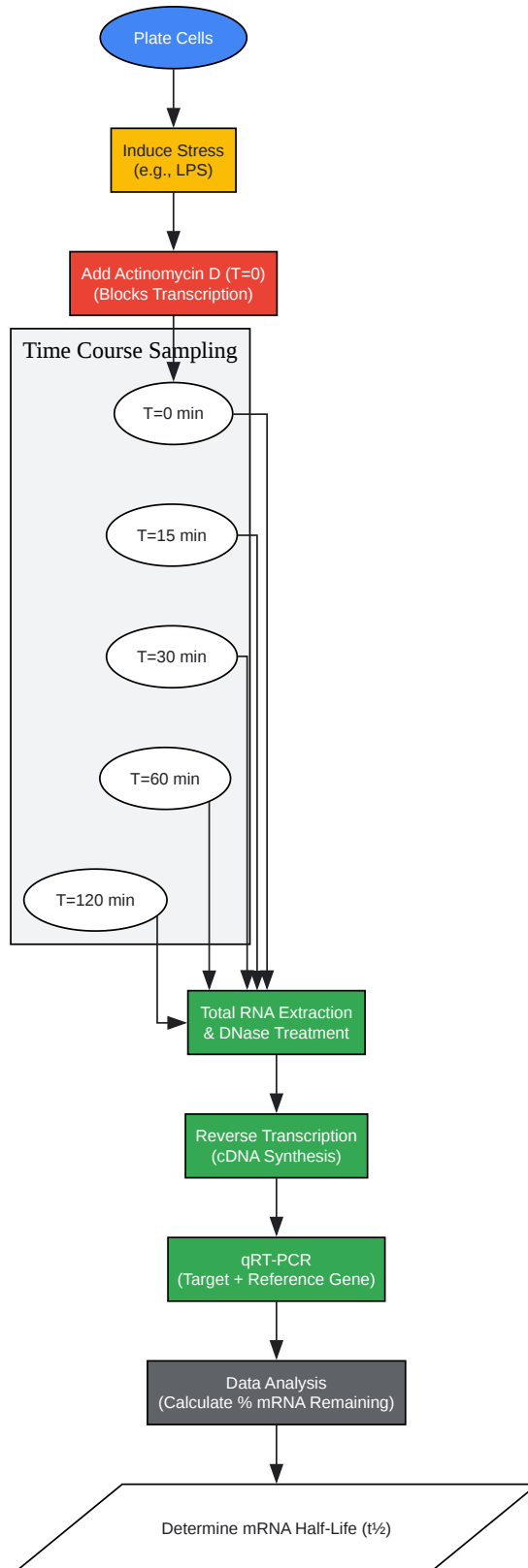

[Click to download full resolution via product page](#)

Figure 3. Workflow for Actinomycin D chase mRNA stability assay.

Protocol: RNA Immunoprecipitation (RIP) for ZFP36

This technique identifies the specific mRNAs that are physically associated with an RNA-binding protein of interest within the cell.

Objective: To confirm the *in vivo* binding of ZFP36 to a putative target mRNA (e.g., NOX4 mRNA).

Principle: A specific antibody against ZFP36 is used to immunoprecipitate endogenous ZFP36-mRNA complexes from cell lysates. The co-precipitated RNA is then purified and analyzed by qRT-PCR to identify and quantify the bound transcripts.

Procedure:

- **Cell Harvesting:** Grow cells to confluency (~1-2 x 10⁷ cells per IP). Treat with a relevant stressor if desired to modulate ZFP36 activity or expression. Wash cells with ice-cold PBS.
- **Cell Lysis:** Lyse cells in a polysome lysis buffer containing RNase inhibitors (e.g., SUPERase-In) and protease inhibitors. This buffer is designed to keep ribonucleoprotein (RNP) complexes intact.[15]
- **Lysate Clarification:** Centrifuge the lysate at high speed (e.g., 14,000 rpm) at 4°C to pellet cell debris. Collect the supernatant.
- **Bead Preparation:** Prepare Protein A/G magnetic beads by washing them with lysis buffer.
- **Immunoprecipitation:**
 - Set aside a small aliquot of the lysate as "Input" control.
 - Incubate the remaining lysate with an anti-ZFP36 antibody (typically 5-10 µg) for 2-4 hours or overnight at 4°C with gentle rotation.
 - A parallel sample with a non-specific IgG of the same isotype serves as a negative control.

- **Capture Complexes:** Add the prepared Protein A/G beads to the antibody-lysate mixture and incubate for another 1-2 hours at 4°C to capture the immune complexes.
- **Washing:** Pellet the beads using a magnetic stand and discard the supernatant. Wash the beads extensively (3-5 times) with a high-salt wash buffer to remove non-specific binding, followed by a final wash in PBS.[16]
- **RNA Elution & Purification:** Elute and purify RNA from the beads (and the "Input" sample) using TRIzol or a column-based RNA purification kit. Perform a DNase treatment step.
- **Analysis:** Perform qRT-PCR on the purified RNA from the ZFP36-IP, IgG-IP, and Input samples using primers for the putative target mRNA (e.g., NOX4) and a negative control transcript not expected to bind ZFP36.
- **Data Interpretation:** Results are typically presented as "fold enrichment" in the ZFP36-IP relative to the IgG control, after normalization to input levels. A significant enrichment indicates direct binding.

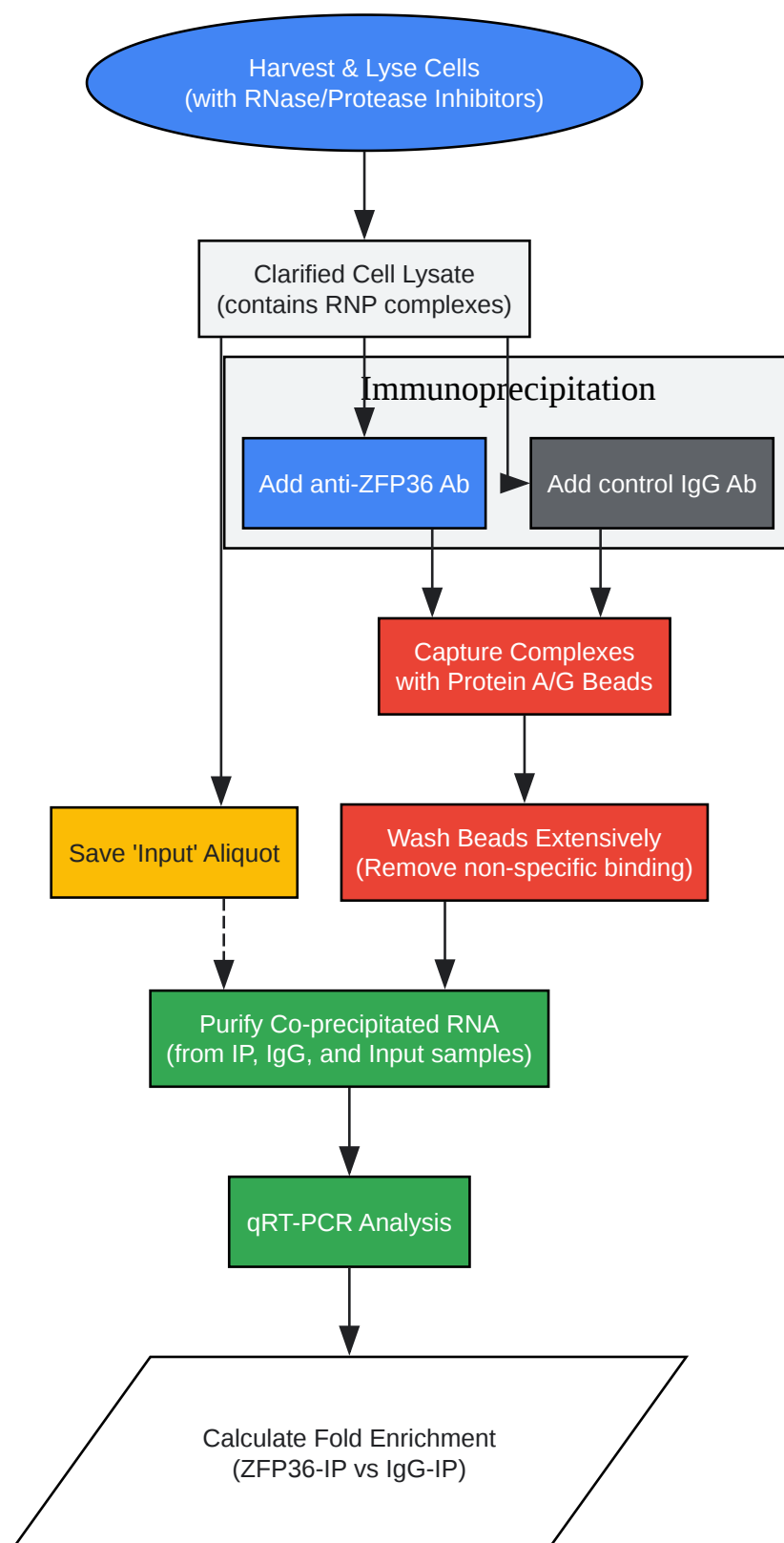

[Click to download full resolution via product page](#)

Figure 4. Workflow for RNA Immunoprecipitation (RIP).

Need Custom Synthesis?

BenchChem offers custom synthesis for rare earth carbides and specific isotopic labeling.

Email: info@benchchem.com or [Request Quote Online](#).

References

- [1. ZFP36-mediated mRNA decay regulates metabolism - PMC \[pmc.ncbi.nlm.nih.gov\]](#)
- [2. Post-Transcriptional Regulation of Immune Responses and Inflammatory Diseases by RNA-Binding ZFP36 Family Proteins - PubMed \[pubmed.ncbi.nlm.nih.gov\]](#)
- [3. Post-Transcriptional Regulation of Immune Responses and Inflammatory Diseases by RNA-Binding ZFP36 Family Proteins - PMC \[pmc.ncbi.nlm.nih.gov\]](#)
- [4. Frontiers | Post-Transcriptional Regulation of Immune Responses and Inflammatory Diseases by RNA-Binding ZFP36 Family Proteins \[frontiersin.org\]](#)
- [5. researchgate.net \[researchgate.net\]](#)
- [6. Negative Feed-forward Control of Tumor Necrosis Factor \(TNF\) by Tristetraprolin \(ZFP36\) Is Limited by the Mitogen-activated Protein Kinase Phosphatase, Dual-specificity Phosphatase 1 \(DUSP1\): IMPLICATIONS FOR REGULATION BY GLUCOCORTICOIDS - PMC \[pmc.ncbi.nlm.nih.gov\]](#)
- [7. Activation of the MKK3-p38-MK2-ZFP36 Axis by Coronavirus Infection Restricts the Upregulation of AU-Rich Element-Containing Transcripts in Proinflammatory Responses - PubMed \[pubmed.ncbi.nlm.nih.gov\]](#)
- [8. Activation of the MKK3-p38-MK2-ZFP36 Axis by Coronavirus Infection Restricts the Upregulation of AU-Rich Element-Containing Transcripts in Proinflammatory Responses - PMC \[pmc.ncbi.nlm.nih.gov\]](#)
- [9. genecards.org \[genecards.org\]](#)
- [10. researchgate.net \[researchgate.net\]](#)
- [11. ZFP36 protects against oxygen-glucose deprivation/reoxygenation-induced mitochondrial fragmentation and neuronal apoptosis through inhibiting NOX4-DRP1 pathway - PubMed \[pubmed.ncbi.nlm.nih.gov\]](#)
- [12. RNA-binding protein ZFP36L1 regulates osteoarthritis by modulating members of the heat shock protein 70 family - PMC \[pmc.ncbi.nlm.nih.gov\]](#)
- [13. iovs.arvojournals.org \[iovs.arvojournals.org\]](#)

- [14. mRNA Stability Assay Using transcription inhibition by Actinomycin D in Mouse Pluripotent Stem Cells - PMC \[pmc.ncbi.nlm.nih.gov\]](#)
- [15. Ribonucleoprotein Immunoprecipitation \(RIP\) Analysis - PMC \[pmc.ncbi.nlm.nih.gov\]](#)
- [16. docs.abcam.com \[docs.abcam.com\]](#)
- To cite this document: BenchChem. [The Role of ZFP36 in Cellular Stress Responses: A Technical Guide]. BenchChem, [2026]. [Online PDF]. Available at: [\[https://www.benchchem.com/product/b12397880/docs#the-role-of-zfp36-in-cellular-stress-responses-a-technical-guide\]](https://www.benchchem.com/product/b12397880/docs#the-role-of-zfp36-in-cellular-stress-responses-a-technical-guide)

Disclaimer & Data Validity:

The information provided in this document is for Research Use Only (RUO) and is strictly not intended for diagnostic or therapeutic procedures. While BenchChem strives to provide accurate protocols, we make no warranties, express or implied, regarding the fitness of this product for every specific experimental setup.

Technical Support: The protocols provided are for reference purposes. Unsure if this reagent suits your experiment?

Need Industrial/Bulk Grade? [Request Custom Synthesis Quote](#)

BenchChem

Our mission is to be the trusted global source of essential and advanced chemicals, empowering scientists and researchers to drive progress in science and industry.

Contact

Address: 3281 E Guasti Rd
Ontario, CA 91761, United States
Phone: (601) 213-4426
Email: info@benchchem.com

[Contact our Ph.D. Support Team for a compatibility check](#)

