

LUF7244 Modulation of Kv11.1 Channel Gating: A Technical Guide

Author: BenchChem Technical Support Team. **Date:** April 2026

Compound of Interest

Compound Name: LUF7244
Cat. No.: B12397052

[Get Quote](#)

For Researchers, Scientists, and Drug Development Professionals

This technical guide provides an in-depth analysis of the pharmacological modulation of the Kv11.1 (hERG) potassium channel by **LUF7244**. **LUF7244** is identified as a negative allosteric modulator and activator of the Kv11.1 channel, a critical component in cardiac repolarization. Blockade of this channel is a known cause of drug-induced cardiac arrhythmias.^{[1][2][3]} **LUF7244** presents a potential therapeutic strategy to counteract the proarrhythmic effects of drugs that inhibit the Kv11.1 channel.^{[1][4]}

Core Mechanism of Action

LUF7244 functions by allosterically modulating the Kv11.1 channel to increase the potassium current ($I_{Kv11.1}$). Molecular docking and dynamics simulations predict that **LUF7244** binds to a site between the pore helices of two adjacent subunits of the channel.^[1] This interaction is thought to stabilize the channel in its conductive state, primarily by inhibiting the process of inactivation.^{[1][3]} This leads to an overall increase in the current conducted by the channel.

The proposed mechanism involves interactions with key amino acid residues, including F557 in the S5 helix, F619 in the P-helix, Y652 in the S6 helix, and T623 in the selectivity filter.^[1] By

stabilizing the open state, **LUF7244** effectively counteracts the effects of channel blockers like dofetilide.

Quantitative Data Summary

The following tables summarize the key quantitative effects of **LUF7244** on Kv11.1 channel function and related physiological parameters as documented in preclinical studies.

Table 1: In Vitro Electrophysiological Effects of **LUF7244**

Parameter	Species/Cell Type	Concentration	Effect	Reference
I _{Kv11.1}	Human (HEK293 cells)	0.5–10 μM	Concentration-dependent increase	[1][3]
I _{Kr}	Canine Cardiomyocytes	10 μM	Doubled the current	[1][3]
Action Potential Duration (APD)	Human iPSC-CMCs & Canine Cardiomyocytes	10 μM	Shortened by ~50%	[1][3]
I _{KIR2.1} , I _{Nav1.5} , I _{Ca-L} , I _{Ks}	-	10 μM	No effect	[1][3]

Table 2: In Vivo Electrophysiological Effects of **LUF7244** in a Canine Model

Parameter	Condition	Dosage	Effect	Reference
QTc Interval	Sinus Rhythm	2.5 mg·kg ⁻¹ ·15 min ⁻¹	-6.8% (non-significant shortening)	[1][3]
RR Interval	Sinus Rhythm	2.5 mg·kg ⁻¹ ·15 min ⁻¹	Decrease from 581±21 ms to 516±13 ms	[4]
QTc Interval	Sinus Rhythm	2.5 mg·kg ⁻¹ ·15 min ⁻¹	Decrease from 302±13 ms to 281±11 ms	[4]
Right Ventricular MAPD	Sinus Rhythm	2.5 mg·kg ⁻¹ ·15 min ⁻¹	Decrease from 174±16 ms to 160±12 ms	[4]
Left Ventricular MAPD	Sinus Rhythm	2.5 mg·kg ⁻¹ ·15 min ⁻¹	Decrease from 198±17 ms to 181±11 ms	[4]
Dofetilide-induced Torsades de Pointes	Chronic Atrioventricular Block	2.5 mg·kg ⁻¹ ·15 min ⁻¹	Prevented in 5 out of 7 animals	[1][3]

 Table 3: Pharmacokinetic Parameters of **LUF7244** in a Canine Model

Parameter	Condition	Value (µM)	Reference
Peak Plasma Level	Sinus Rhythm	1.75 ± 0.80	[1][3]
Peak Plasma Level	Chronic Atrioventricular Block	2.34 ± 1.57	[1][3]

Experimental Protocols

In Vitro Electrophysiology

Cell Preparation:

- Human embryonic kidney (HEK293) cells stably expressing the human Kv11.1 channel were used for patch-clamp experiments.
- Cardiomyocytes were isolated from canine ventricles and derived from human induced pluripotent stem cells (hiPSC-CMCs).

Whole-Cell Patch Clamp:

- Voltage-Clamp: To measure $I_{Kv11.1}$, cells were held at a holding potential of -80 mV. Depolarizing steps were applied to various test potentials to elicit channel activation. The effect of **LUF7244** was assessed by comparing currents before and after drug application.
- Current-Clamp: Action potentials were recorded in isolated cardiomyocytes by injecting 2 ms current pulses at a frequency of 0.5 Hz. Changes in action potential duration (APD) were measured.
- Solutions: The bath solution (extracellular) typically contained (in mM): 140 NaCl, 5.4 KCl, 1.8 CaCl₂, 1 MgCl₂, 10 HEPES, and 10 glucose, with the pH adjusted to 7.4. The pipette solution (intracellular) typically contained (in mM): 110 K-aspartate, 20 KCl, 1 MgCl₂, 10 HEPES, 5 EGTA, and 5 MgATP, with the pH adjusted to 7.2.
- Temperature: All in vitro experiments were performed at 37°C.

In Vivo Studies in a Canine Model

Animal Model:

- Anesthetized dogs were used, either in normal sinus rhythm or with surgically induced chronic atrioventricular block, the latter being a model sensitive to Torsades de Pointes arrhythmia.

Data Acquisition:

- Electrocardiograms (ECG) and monophasic action potentials (MAP) from the right and left ventricles were continuously recorded.

- ECG parameters (RR, PQ, QRS, QT intervals) were measured, and the QT interval was corrected for heart rate using Van de Water's formula ($QTc = QT - 0.087 * (RR - 1000)$).
- **LUF7244** was administered intravenously.
- In the arrhythmia model, the I_{Kr} blocker dofetilide (0.025 mg/kg over 5 min) was infused to induce Torsades de Pointes. The efficacy of **LUF7244** was tested in a prevention protocol where it was administered prior to dofetilide.

Visualized Pathways and Workflows

The following diagrams illustrate the mechanism of action of **LUF7244** and its experimental workflow.

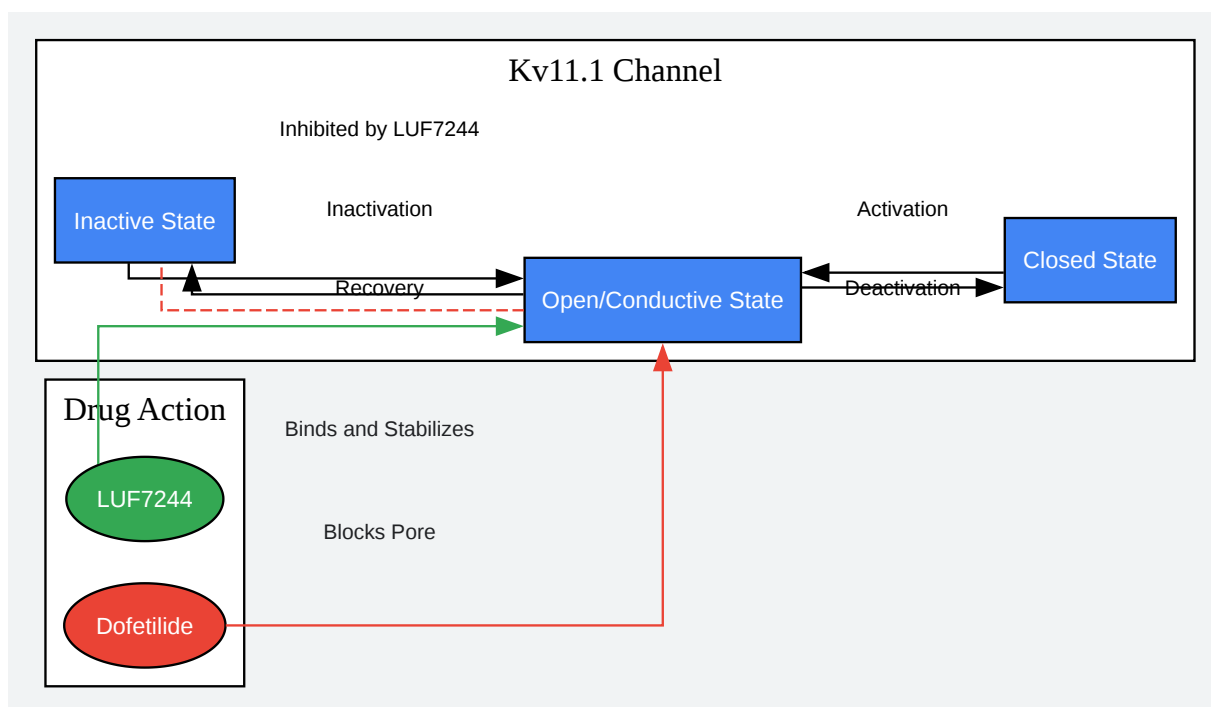

[Click to download full resolution via product page](#)

Caption: Mechanism of **LUF7244** on Kv11.1 channel gating states.

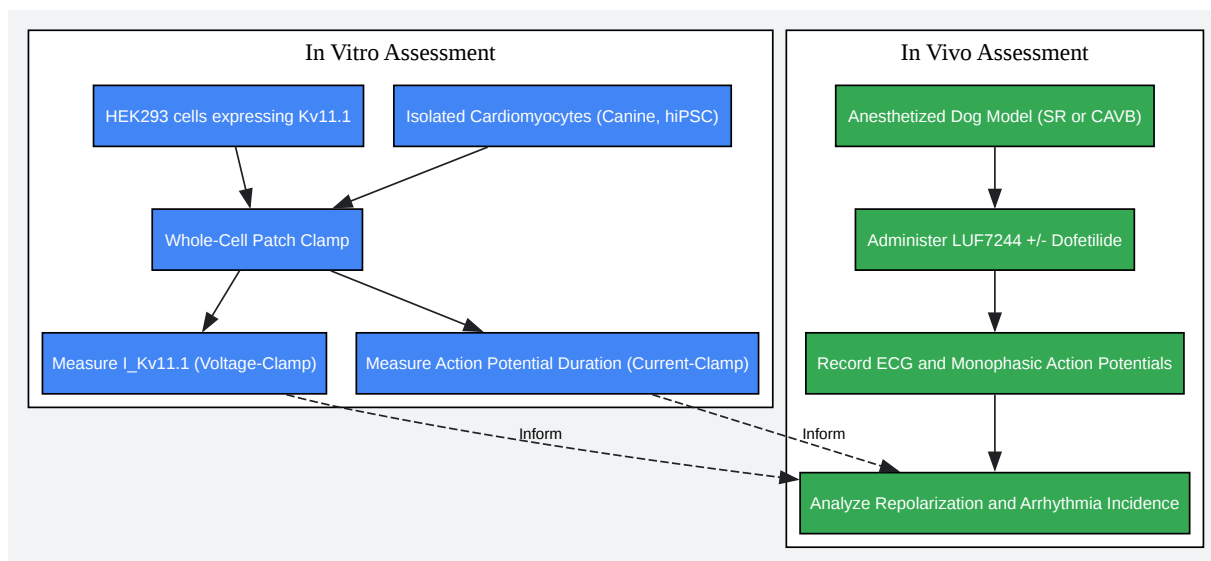

[Click to download full resolution via product page](#)

Caption: Experimental workflow for evaluating **LUF7244**'s effects.

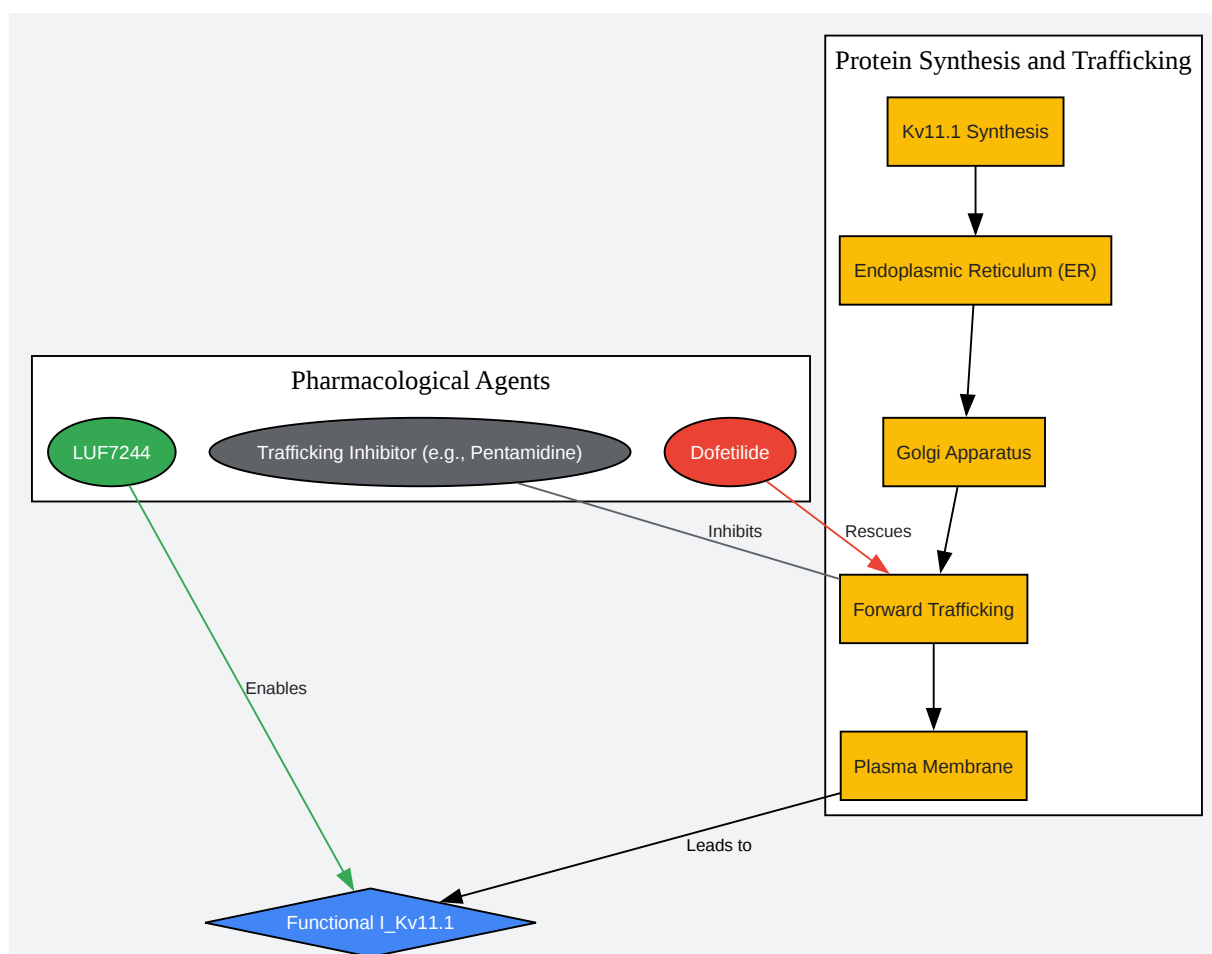

[Click to download full resolution via product page](#)

Caption: **LUF7244** and dofetilide in rescuing Kv11.1 trafficking.[5]

Need Custom Synthesis?

BenchChem offers custom synthesis for rare earth carbides and specific isotopic labeling.

Email: info@benchchem.com or [Request Quote Online](#).

References

- 1. LUF7244, an allosteric modulator/activator of Kv11.1 channels, counteracts dofetilide-induced torsades de pointes arrhythmia in the chronic atrioventricular block dog model - PMC [pmc.ncbi.nlm.nih.gov]
- 2. researchgate.net [researchgate.net]
- 3. LUF7244, an allosteric modulator/activator of Kv 11.1 channels, counteracts dofetilide-induced torsades de pointes arrhythmia in the chronic atrioventricular block dog model - PubMed [pubmed.ncbi.nlm.nih.gov]
- 4. academic.oup.com [academic.oup.com]
- 5. LUF7244 plus Dofetilide Rescues Aberrant Kv11.1 Trafficking and Produces Functional IKv11.1 - PubMed [pubmed.ncbi.nlm.nih.gov]
- To cite this document: BenchChem. [LUF7244 Modulation of Kv11.1 Channel Gating: A Technical Guide]. BenchChem, [2026]. [Online PDF]. Available at: [https://www.benchchem.com/product/b12397052/docs#luf7244-modulation-of-kv11-1-channel-gating-a-technical-guide]

Disclaimer & Data Validity:

The information provided in this document is for Research Use Only (RUO) and is strictly not intended for diagnostic or therapeutic procedures. While BenchChem strives to provide accurate protocols, we make no warranties, express or implied, regarding the fitness of this product for every specific experimental setup.

Technical Support: The protocols provided are for reference purposes. Unsure if this reagent suits your experiment?

Need Industrial/Bulk Grade? [Request Custom Synthesis Quote](#)

BenchChem

Our mission is to be the trusted global source of essential and advanced chemicals, empowering scientists and researchers to drive progress in science and industry.

Contact

Address: 3281 E Guasti Rd

Ontario, CA 91761, United States

Phone: (601) 213-4426

Email: info@benchchem.com

[Contact our Ph.D. Support Team for a compatibility check](#)