

Application Notes and Protocols for hERG Channel Assays Using LUF7244

Author: BenchChem Technical Support Team. **Date:** April 2026

Compound of Interest

Compound Name: LUF7244
Cat. No.: B12397052

[Get Quote](#)

For Researchers, Scientists, and Drug Development Professionals

Introduction

The human Ether-à-go-go-Related Gene (hERG) encodes the pore-forming alpha-subunit of the rapidly activating delayed rectifier potassium channel (IKr). This channel is critical for cardiac repolarization, and its inhibition can lead to QT interval prolongation, a major risk factor for developing life-threatening arrhythmias such as Torsades de Pointes (TdP).[1]

Consequently, assessing the potential of drug candidates to interact with the hERG channel is a critical step in preclinical safety evaluation.

LUF7244 is a small molecule identified as a negative allosteric modulator and activator of the hERG (Kv11.1) channel.[2][3] It exerts its effects by inhibiting the rapid inactivation of the channel, thereby increasing the overall hERG current.[1][2] This property makes **LUF7244** a valuable research tool for studying hERG channel gating and for developing potential therapeutic strategies to counteract the effects of hERG-blocking drugs.[2][3]

These application notes provide detailed protocols for utilizing **LUF7244** in hERG channel assays, primarily focusing on electrophysiological assessments using the whole-cell patch-clamp technique in a recombinant cell line.

hERG Channel Gating and Mechanism of LUF7244 Action

The hERG channel exhibits unique gating kinetics characterized by slow activation and rapid, voltage-dependent inactivation.[4][5] The channel transitions between three main conformational states: closed, open, and inactivated.[4][5] Upon membrane depolarization, the channel slowly moves from the closed to the open state, allowing potassium ion efflux. However, at sustained depolarized potentials, the channel rapidly enters a non-conducting inactivated state. This rapid inactivation limits the outward potassium current during the plateau phase of the cardiac action potential.

LUF7244 modulates this process by binding to an allosteric site on the hERG channel, which is distinct from the binding site of many classical hERG blockers.[3] This binding stabilizes the open state of the channel and inhibits the transition to the inactivated state.[2] The net effect is an increased outward hERG current, particularly at positive membrane potentials where inactivation is most prominent.

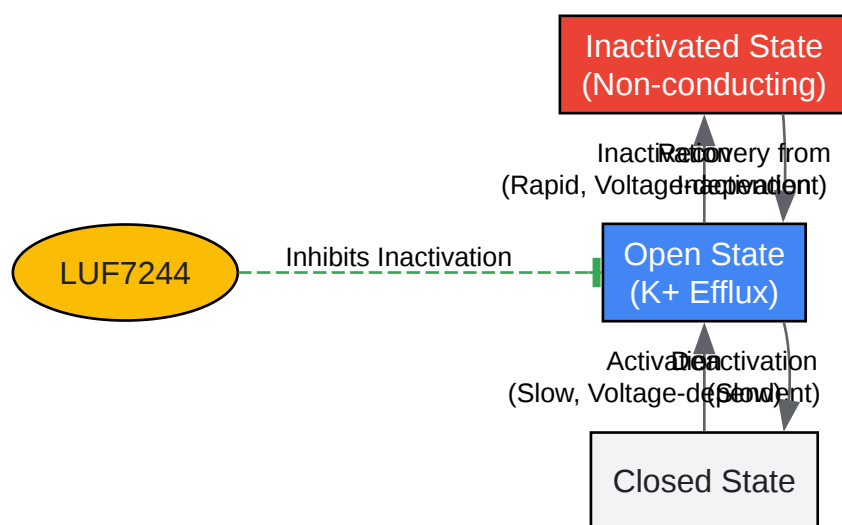

[Click to download full resolution via product page](#)

hERG channel gating states and the inhibitory effect of **LUF7244** on inactivation.

Quantitative Data: Electrophysiological Effects of LUF7244 on hERG Channels

The following data summarizes the concentration-dependent effects of **LUF7244** on hERG currents (IKv11.1) recorded from HEK293 cells stably expressing the hERG channel (HEK-hERG cells) using whole-cell patch-clamp electrophysiology.[2][6]

LUF7244 Concentration	Key Observations on hERG Current (IKv11.1)	Other Ion Channels (at 10 μ M)
0.5 μ M	Noticeable increase in steady-state outward current.[6]	Not reported.
3 μ M	Significant, concentration-dependent increase in steady-state outward current.[6]	Not reported.
10 μ M	Marked increase in steady-state outward current.[6]	No significant effect on IKIR2.1, INav1.5, ICa-L, and IKs.[1][2]
Doubled the native IKr current in cardiomyocytes.[1][2]		
Shortened action potential duration by approximately 50% in human and canine cardiomyocytes.[1][2]		

Note: The quantitative effects on current amplitude can be extracted from the current-voltage (I-V) relationship curves presented in the cited literature. The data indicates a clear dose-dependent increase in the outward hERG current at depolarizing potentials.

Experimental Protocols

Manual and Automated Whole-Cell Patch-Clamp Assay in HEK-hERG Cells

This protocol describes the methodology for assessing the effect of **LUF7244** on hERG channel currents using either manual or automated whole-cell patch-clamp systems.

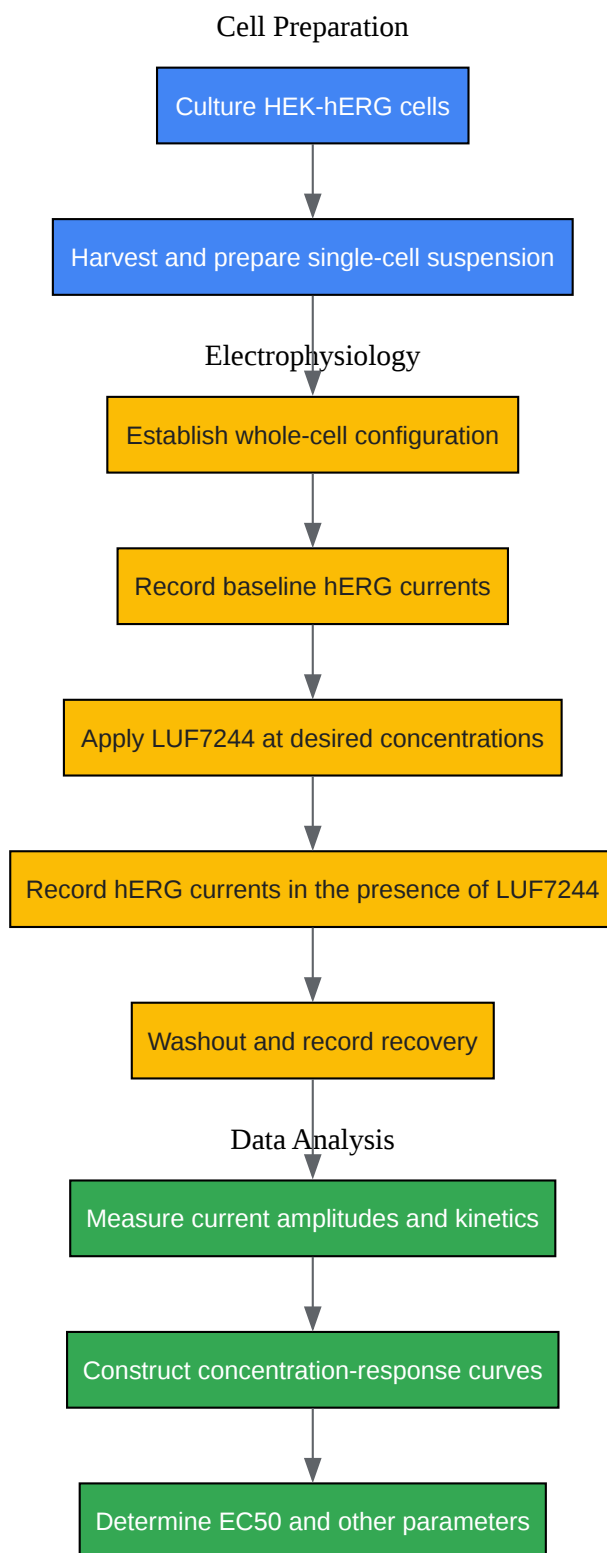

[Click to download full resolution via product page](#)

Workflow for assessing **LUF7244** effects on hERG channels via patch-clamp.

1. Cell Culture and Preparation

- Cell Line: Human Embryonic Kidney (HEK293) cells stably expressing the human hERG channel (HEK-hERG).
- Culture Medium: Dulbecco's Modified Eagle's Medium (DMEM) supplemented with 10% Fetal Bovine Serum (FBS), 1% Penicillin-Streptomycin, and a selection antibiotic (e.g., G418) to maintain hERG expression.
- Culture Conditions: Maintain cells at 37°C in a humidified atmosphere with 5% CO₂.
- Cell Preparation for Electrophysiology:
 - Aspirate the culture medium and wash the cells with Phosphate-Buffered Saline (PBS).
 - Detach the cells using a non-enzymatic cell dissociation solution or brief trypsinization.
 - Resuspend the cells in the extracellular solution to a final density of approximately 1 x 10⁶ cells/mL.
 - For automated patch-clamp systems, follow the manufacturer's instructions for cell preparation and loading.

2. Solutions and Reagents

- Intracellular (Pipette) Solution (in mM): 120 KCl, 5.374 CaCl₂, 1.75 MgCl₂, 10 EGTA, 10 HEPES, 4 Mg-ATP. Adjust pH to 7.2 with KOH.[7]
- Extracellular (Bath) Solution (in mM): 145 NaCl, 4 KCl, 2 CaCl₂, 1 MgCl₂, 10 HEPES, 10 Glucose. Adjust pH to 7.4 with NaOH.[7]
- **LUF7244** Stock Solution: Prepare a high-concentration stock solution (e.g., 10 mM) in Dimethyl Sulfoxide (DMSO).
- Test Solutions: Serially dilute the **LUF7244** stock solution in the extracellular solution to achieve the desired final concentrations (e.g., 0.5, 3, and 10 μM). The final DMSO concentration should be kept constant across all conditions and typically below 0.1%.

3. Electrophysiological Recording

- Technique: Whole-cell patch-clamp.
- Apparatus: A patch-clamp amplifier, data acquisition system, and microscope. For automated systems, use the appropriate platform (e.g., QPatch, SyncroPatch).
- Pipettes: Pull borosilicate glass capillaries to a resistance of 2-5 M Ω when filled with the intracellular solution.
- Procedure:
 - Obtain a high-resistance (>1 G Ω) seal between the patch pipette and the cell membrane.
 - Rupture the cell membrane to achieve the whole-cell configuration.
 - Allow the cell to stabilize for a few minutes before starting the recording.
 - Apply the voltage protocol and record baseline hERG currents in the extracellular solution.
 - Perfuse the cell with the test solutions containing different concentrations of **LUF7244** and record the steady-state effects.
 - Perform a washout with the extracellular solution to assess the reversibility of the drug effect.

4. Voltage-Clamp Protocol

A voltage protocol designed to elicit and characterize hERG currents is crucial. A commonly used protocol involves:

- A holding potential of -80 mV.
- A depolarizing step to a positive potential (e.g., +20 mV to +40 mV) for a duration sufficient to induce channel activation and subsequent inactivation (e.g., 1-2 seconds).
- A repolarizing step to a negative potential (e.g., -50 mV) to elicit a large tail current as channels recover from inactivation to the open state before deactivating.[8]

The peak amplitude of the tail current is often used to quantify the hERG current as it is less contaminated by other currents and reflects the population of channels that were open at the end of the depolarizing pulse.

5. Data Analysis

- Measure the peak tail current amplitude in the absence (control) and presence of different concentrations of **LUF7244**.
- Normalize the current in the presence of **LUF7244** to the control current to determine the percentage of current increase.
- Plot the percentage increase in current as a function of the **LUF7244** concentration.
- If a full concentration-response relationship is established, fit the data to a suitable equation (e.g., the Hill equation) to determine the EC50 (the concentration that elicits 50% of the maximal effect).
- Analyze changes in the current-voltage (I-V) relationship and channel kinetics (e.g., time constants of inactivation and deactivation) to further characterize the modulatory effects of **LUF7244**.

Need Custom Synthesis?

BenchChem offers custom synthesis for rare earth carbides and specific isotopic labeling.

Email: info@benchchem.com or [Request Quote Online](#).

References

- 1. LUF7244, an allosteric modulator/activator of Kv 11.1 channels, counteracts dofetilide-induced torsades de pointes arrhythmia in the chronic atrioventricular block dog model - PubMed [pubmed.ncbi.nlm.nih.gov]
- 2. LUF7244, an allosteric modulator/activator of Kv11.1 channels, counteracts dofetilide-induced torsades de pointes arrhythmia in the chronic atrioventricular block dog model - PMC [pmc.ncbi.nlm.nih.gov]
- 3. [researchgate.net](https://www.researchgate.net) [[researchgate.net](https://www.researchgate.net)]

- [4. Molecular Insights Into the Gating Kinetics of the Cardiac hERG Channel, Illuminated by Structure and Molecular Dynamics - PMC \[pmc.ncbi.nlm.nih.gov\]](#)
- [5. Getting to the heart of hERG K+ channel gating - PMC \[pmc.ncbi.nlm.nih.gov\]](#)
- [6. researchgate.net \[researchgate.net\]](#)
- [7. sophion.com \[sophion.com\]](#)
- [8. Electrophysiological analysis of mammalian cells expressing hERG using automated 384-well-patch-clamp - PMC \[pmc.ncbi.nlm.nih.gov\]](#)
- To cite this document: BenchChem. [Application Notes and Protocols for hERG Channel Assays Using LUF7244]. BenchChem, [2026]. [Online PDF]. Available at: [\[https://www.benchchem.com/product/b12397052/docs#application-notes-and-protocols-for-herg-channel-assays-using-luf7244\]](https://www.benchchem.com/product/b12397052/docs#application-notes-and-protocols-for-herg-channel-assays-using-luf7244)

Disclaimer & Data Validity:

The information provided in this document is for Research Use Only (RUO) and is strictly not intended for diagnostic or therapeutic procedures. While BenchChem strives to provide accurate protocols, we make no warranties, express or implied, regarding the fitness of this product for every specific experimental setup.

Technical Support: The protocols provided are for reference purposes. Unsure if this reagent suits your experiment?

Need Industrial/Bulk Grade? [Request Custom Synthesis Quote](#)

BenchChem

Our mission is to be the trusted global source of essential and advanced chemicals, empowering scientists and researchers to drive progress in science and industry.

Contact

Address: 3281 E Guasti Rd
Ontario, CA 91761, United States
Phone: (601) 213-4426
Email: info@benchchem.com

Contact our Ph.D. Support Team for a compatibility check