

# Application Notes and Protocols for AChE-IN-34 in Cholinergic Pathway Research

**Author:** BenchChem Technical Support Team. **Date:** April 2026

## Compound of Interest

Compound Name: AChE-IN-34

Cat. No.: B12397476

[Get Quote](#)

For Researchers, Scientists, and Drug Development Professionals

## Introduction

**AChE-IN-34** is a potent and selective inhibitor of acetylcholinesterase (AChE), the primary enzyme responsible for the hydrolysis of the neurotransmitter acetylcholine (ACh) in synaptic clefts.[1] By inhibiting AChE, **AChE-IN-34** increases the concentration and duration of action of ACh at cholinergic synapses, making it a valuable tool for studying the role of cholinergic pathways in various physiological and pathological processes.[2][3] These pathways are crucial for cognitive functions such as memory and learning, as well as for the regulation of movement and autonomic functions.[4][5][6] Dysregulation of cholinergic signaling is implicated in several neurological disorders, including Alzheimer's disease.[2]

This document provides detailed application notes and experimental protocols for the use of **AChE-IN-34** in both in vitro and in vivo research settings.

## Mechanism of Action

**AChE-IN-34** acts as a competitive inhibitor of acetylcholinesterase. It binds to the active site of the AChE enzyme, preventing the breakdown of acetylcholine into choline and acetate.[1][7]

This leads to an accumulation of acetylcholine in the synaptic cleft, thereby enhancing the stimulation of both nicotinic and muscarinic acetylcholine receptors on postsynaptic neurons.[3][7] This enhanced cholinergic transmission is the basis for its utility in studying the functional roles of cholinergic systems.

## Quantitative Data Summary

The following tables summarize the key quantitative parameters of **AChE-IN-34** based on in vitro enzymatic assays.

Table 1: In Vitro Inhibitory Activity of **AChE-IN-34**

Parameter	Value	Enzyme Source
IC50 (AChE)	15 nM	Human recombinant AChE
IC50 (BuChE)	350 nM	Human serum BuChE
Ki (AChE)	8.5 nM	Human recombinant AChE
Selectivity Index (BuChE/AChE)	23.3	

Table 2: Kinetic Parameters of AChE Inhibition by **AChE-IN-34**

Parameter	Value	Assay Condition
Inhibition Type	Competitive	Lineweaver-Burk analysis
Association Rate Constant (kon)	$2.1 \times 10^7 \text{ M}^{-1}\text{min}^{-1}$	Surface Plasmon Resonance
Dissociation Rate Constant (koff)	$0.18 \text{ min}^{-1}$	Surface Plasmon Resonance

## Signaling Pathway Diagram

The following diagram illustrates the effect of **AChE-IN-34** on the cholinergic signaling pathway.

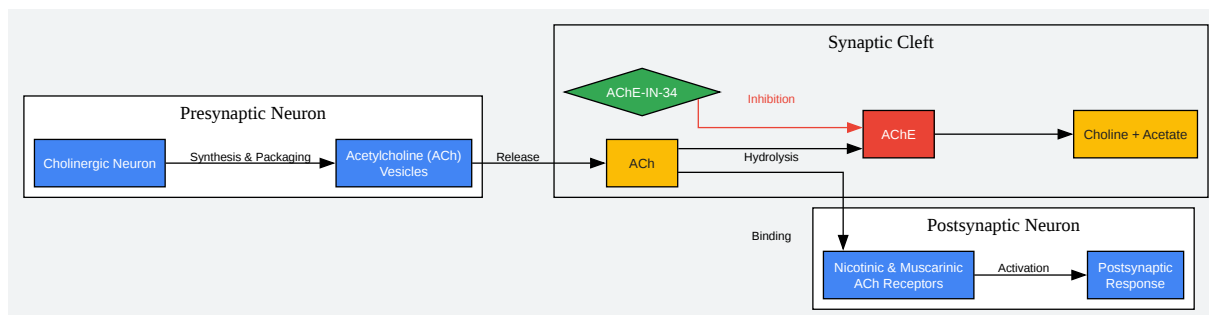

[Click to download full resolution via product page](#)

Caption: Effect of **AChE-IN-34** on cholinergic neurotransmission.

## Experimental Protocols

### In Vitro AChE Inhibition Assay (Ellman's Method)

This protocol describes a colorimetric method to determine the in vitro inhibitory activity of **AChE-IN-34**.

Materials:

- **AChE-IN-34**
- Acetylcholinesterase (AChE) from electric eel or human recombinant
- Acetylthiocholine iodide (ATCI)
- 5,5'-Dithiobis-(2-nitrobenzoic acid) (DTNB, Ellman's reagent)
- Phosphate buffer (pH 8.0)
- 96-well microplate

- Microplate reader

Procedure:

- Prepare a stock solution of **AChE-IN-34** in a suitable solvent (e.g., DMSO).
- Prepare serial dilutions of **AChE-IN-34** in phosphate buffer.
- In a 96-well plate, add 20  $\mu$ L of the **AChE-IN-34** dilutions to each well. Include a control group with buffer and a positive control with a known AChE inhibitor (e.g., donepezil).
- Add 140  $\mu$ L of phosphate buffer to all wells.
- Add 20  $\mu$ L of AChE solution to all wells and incubate for 15 minutes at 37°C.
- Add 10  $\mu$ L of DTNB solution to all wells.
- Initiate the reaction by adding 10  $\mu$ L of ATCI solution to all wells.
- Immediately measure the absorbance at 412 nm every minute for 10 minutes using a microplate reader.
- Calculate the rate of reaction for each concentration of **AChE-IN-34**.
- Plot the percentage of inhibition versus the logarithm of the inhibitor concentration to determine the IC50 value.

## Cell-Based Assay for Neurite Outgrowth

This protocol assesses the neuroprotective or neurotrophic effects of **AChE-IN-34** on a neuronal cell line.

Materials:

- Neuronal cell line (e.g., PC12 or SH-SY5Y)
- Cell culture medium (e.g., DMEM with fetal bovine serum)
- **AChE-IN-34**

- Nerve Growth Factor (NGF) for differentiation (if required)
- A neurotoxic agent (e.g., amyloid-beta peptide) for protection studies
- Microscope with imaging software

Procedure:

- Plate neuronal cells in a 24-well plate at an appropriate density.
- If necessary, differentiate the cells using NGF for several days.
- Treat the cells with various concentrations of **AChE-IN-34**. For neuroprotection studies, co-treat with the neurotoxic agent.
- Incubate the cells for 24-48 hours.
- Capture images of the cells using a microscope.
- Quantify neurite length and number of neurites per cell using imaging software.
- Analyze the data to determine the effect of **AChE-IN-34** on neurite outgrowth.

## In Vivo Microdialysis for Acetylcholine Measurement in Rodents

This protocol measures the effect of **AChE-IN-34** on extracellular acetylcholine levels in a specific brain region of an anesthetized or freely moving rodent.

Materials:

- **AChE-IN-34**
- Anesthetized or freely moving rat/mouse model
- Stereotaxic apparatus
- Microdialysis probes

- Perfusion pump
- Fraction collector
- HPLC system with electrochemical detection for ACh analysis
- Artificial cerebrospinal fluid (aCSF)

#### Procedure:

- Implant a guide cannula stereotaxically into the brain region of interest (e.g., hippocampus or prefrontal cortex).
- After a recovery period, insert a microdialysis probe through the guide cannula.
- Perfuse the probe with aCSF at a constant flow rate (e.g., 1  $\mu$ L/min).
- Collect baseline dialysate samples every 20 minutes.
- Administer **AChE-IN-34** systemically (e.g., via intraperitoneal injection) or locally through the probe.
- Continue collecting dialysate samples for several hours post-administration.
- Analyze the concentration of acetylcholine in the dialysate samples using HPLC-ECD.
- Express the post-administration ACh levels as a percentage of the baseline levels.

## Experimental Workflow Diagram

The following diagram outlines a typical workflow for screening and characterizing a novel acetylcholinesterase inhibitor like **AChE-IN-34**.

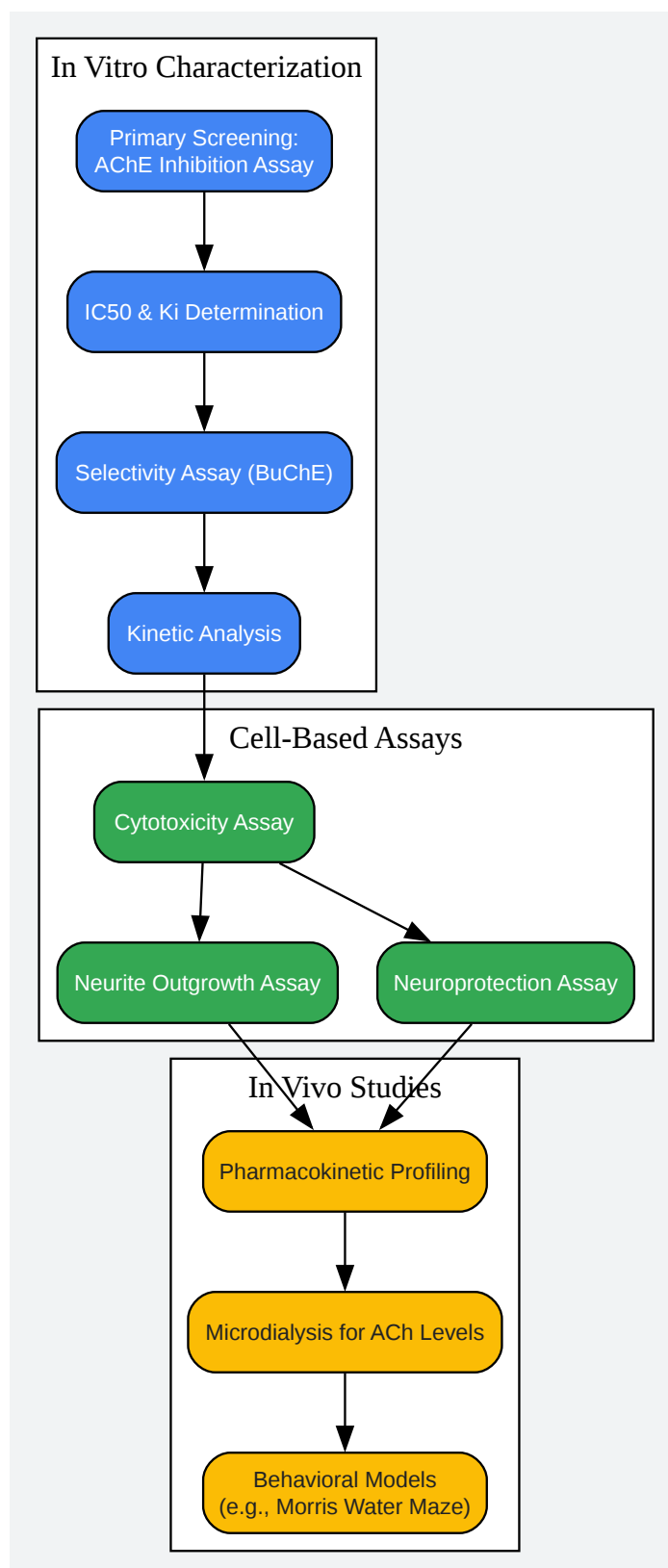

[Click to download full resolution via product page](#)

Caption: A typical workflow for characterizing AChE inhibitors.

## Conclusion

**AChE-IN-34** is a valuable pharmacological tool for the investigation of cholinergic pathways. Its high potency and selectivity for AChE allow for precise modulation of cholinergic neurotransmission. The protocols and data presented here provide a framework for researchers to effectively utilize **AChE-IN-34** in their studies to elucidate the role of the cholinergic system in health and disease. As with any potent bioactive compound, appropriate safety precautions and handling procedures should be followed.

### *Need Custom Synthesis?*

*BenchChem offers custom synthesis for rare earth carbides and specific isotopic labeling.*

*Email: [info@benchchem.com](mailto:info@benchchem.com) or [Request Quote Online](#).*

## References

- [1. Physiology, Acetylcholinesterase - StatPearls - NCBI Bookshelf \[ncbi.nlm.nih.gov\]](#)
- [2. Multitarget-Directed Ligands for Alzheimer's Disease: Recent Novel MTDLs and Mechanistic Insights \[mdpi.com\]](#)
- [3. Acetylcholine Neurotransmission \(Section 1, Chapter 11\) Neuroscience Online: An Electronic Textbook for the Neurosciences | Department of Neurobiology and Anatomy - The University of Texas Medical School at Houston \[nba.uth.tmc.edu\]](#)
- [4. discovery.researcher.life \[discovery.researcher.life\]](#)
- [5. Acetylcholine and cholinergic receptors - PMC \[pmc.ncbi.nlm.nih.gov\]](#)
- [6. Basic and modern concepts on cholinergic receptor: A review - PMC \[pmc.ncbi.nlm.nih.gov\]](#)
- [7. VX \(nerve agent\) - Wikipedia \[en.wikipedia.org\]](#)
- To cite this document: BenchChem. [Application Notes and Protocols for AChE-IN-34 in Cholinergic Pathway Research]. BenchChem, [2026]. [Online PDF]. Available at: [<https://www.benchchem.com/product/b12397476/docs#application-notes-and-protocols-for-ache-in-34-in-cholinergic-pathway-research>]

---

### Disclaimer & Data Validity:

The information provided in this document is for Research Use Only (RUO) and is strictly not intended for diagnostic or therapeutic procedures. While BenchChem strives to provide accurate protocols, we make no warranties, express or implied, regarding the fitness of this product for every specific experimental setup.

**Technical Support:** The protocols provided are for reference purposes. Unsure if this reagent suits your experiment?

**Need Industrial/Bulk Grade?** [Request Custom Synthesis Quote](#)

## BenchChem

Our mission is to be the trusted global source of essential and advanced chemicals, empowering scientists and researchers to drive progress in science and industry.

### Contact

Address: 3281 E Guasti Rd  
Ontario, CA 91761, United States  
Phone: (601) 213-4426  
Email: [info@benchchem.com](mailto:info@benchchem.com)

[Contact our Ph.D. Support Team for a compatibility check](#)