

An In-depth Technical Guide to Lsd1-IN-22 and its Paralog LSD2

Author: BenchChem Technical Support Team. **Date:** April 2026

Compound of Interest

Compound Name: *Lsd1-IN-22*

Cat. No.: *B12397650*

[Get Quote](#)

For Researchers, Scientists, and Drug Development Professionals

Abstract

This technical guide provides a comprehensive overview of the lysine-specific demethylase 1 (LSD1) inhibitor, **Lsd1-IN-22**, and its paralog, lysine-specific demethylase 2 (LSD2). It delves into their structural and functional differences, the mechanism of action of **Lsd1-IN-22**, and the broader context of LSD1 inhibition in therapeutic development. Detailed experimental protocols for key biochemical and cellular assays are provided, alongside a quantitative comparison of various LSD1 inhibitors. Furthermore, this guide illustrates the intricate signaling pathways regulated by LSD1 and the metabolic role of LSD2 through detailed diagrams, offering a valuable resource for researchers in epigenetics and drug discovery.

Introduction: LSD1 and LSD2 - Sibling Enzymes with Distinct Roles

Lysine-specific demethylase 1 (LSD1), also known as KDM1A, and its paralog LSD2 (KDM1B) are flavin adenine dinucleotide (FAD)-dependent amine oxidases that play crucial roles in epigenetic regulation by removing methyl groups from histone and non-histone proteins.^{[1][2]}

While both enzymes share a conserved amine oxidase (AO)-like domain and a SWIRM (Swi3p, Rsc8p, and Moira) domain, they exhibit distinct structural features that dictate their specific functions and protein-protein interactions.[1][2]

LSD1 is characterized by a C-terminal Tower domain, which is absent in LSD2 and facilitates its interaction with the CoREST complex, essential for its demethylase activity on nucleosomal substrates.[1][3] In contrast, LSD2 possesses a unique N-terminal zinc-finger domain.[3][4] These structural divergences contribute to their differential substrate specificities and biological roles. LSD1 primarily demethylates mono- and di-methylated histone H3 at lysine 4 (H3K4me1/2) and lysine 9 (H3K9me1/2), thereby acting as both a transcriptional repressor and activator, respectively.[1][2] LSD2 also targets H3K4me1/2 for demethylation.[3]

Given their significant roles in gene regulation and the dysregulation of their activity in various cancers, both LSD1 and LSD2 have emerged as attractive targets for therapeutic intervention.

Lsd1-IN-22: A Potent Inhibitor of LSD1

Lsd1-IN-22 is a potent inhibitor of LSD1, exhibiting a high binding affinity with a reported K_i value of 98 nM. The mechanism of action for many LSD1 inhibitors involves either reversible or irreversible inactivation of the FAD cofactor, which is essential for the demethylation reaction.

Quantitative Comparison of LSD1 Inhibitors

The development of LSD1 inhibitors has been a major focus in cancer research. The following table summarizes the inhibitory potency of **Lsd1-IN-22** in comparison to other well-characterized LSD1 inhibitors.

Inhibitor	Target	IC50 Value	Ki Value	Notes
Lsd1-IN-22	LSD1	Not Reported	98 nM	Potent inhibitor.
ORY-1001 (Iadademstat)	LSD1	12 nM ^[5] , 18 nM ^{[6][7]}	Not Reported	Irreversible inhibitor, selective over LSD2 and MAOs. ^[8] In clinical trials. ^[6]
GSK2879552	LSD1	90 nM ^[7]	Not Reported	Irreversible inhibitor.
Tranlycypromine (TCP)	LSD1, MAO-A/B	~7.8 μ M ^[9] , 14.0 \pm 1.3 μ M (on nucleosomes) ^[10]	30.3 nM (for a TCP derivative) ^[11]	Weak, irreversible inhibitor of LSD1; also inhibits monoamine oxidases. ^{[10][12]}
SP-2577 (Seclidemstat)	LSD1	31 nM ^[10]	Not Reported	Reversible inhibitor. ^[10]
CC-90011 (Pulrodemstat)	LSD1	3.9 \pm 0.3 nM (on nucleosomes) ^[10]	Not Reported	Potent, reversible inhibitor. ^[10]

Experimental Protocols

This section provides detailed methodologies for key experiments commonly used to characterize LSD1/LSD2 inhibitors.

Biochemical Assays

This assay measures the demethylase activity of LSD1 by detecting the product of the enzymatic reaction using a fluorescence-based method.

Principle: The assay utilizes a biotinylated peptide substrate corresponding to the N-terminal tail of histone H3, monomethylated at lysine 4 (H3K4me1). Upon demethylation by LSD1, a

europium cryptate-labeled antibody specific for the demethylated product (H3K4me0) binds to the peptide. The biotinylated peptide is captured by streptavidin-conjugated XL665. The proximity of the europium donor and the XL665 acceptor results in a FRET signal that is proportional to the amount of demethylated product.[9]

Protocol:

- Reagent Preparation:
 - Prepare LSD1 enzyme dilution in assay buffer.
 - Prepare a pre-mixture of the biotinylated H3(1-21)K4me1 peptide substrate and FAD in assay buffer.
 - Prepare inhibitor solutions at various concentrations.
 - Prepare the detection mixture containing Eu³⁺-cryptate-labeled anti-H3K4me0 antibody and streptavidin-XL665 in the detection buffer.
- Enzymatic Reaction:
 - Add 2.5 μL of inhibitor or vehicle control to the wells of a 384-well plate.
 - Add 2.5 μL of the LSD1 enzyme solution.
 - Initiate the reaction by adding 5 μL of the substrate/FAD pre-mixture.
 - Incubate the plate at room temperature for a defined period (e.g., 60 minutes).[9]
- Detection:
 - Stop the reaction by adding 10 μL of the detection mixture.
 - Incubate the plate at room temperature for 60 minutes to allow for signal development.
 - Read the plate on an HTRF-compatible microplate reader, measuring the emission at 665 nm and 620 nm following excitation at 320 nm.

- Data Analysis:
 - Calculate the HTRF ratio ($665 \text{ nm}/620 \text{ nm} * 10,000$).
 - Plot the HTRF ratio against the inhibitor concentration and fit the data to a four-parameter logistic equation to determine the IC50 value.

This spectrophotometric assay continuously measures the production of hydrogen peroxide (H_2O_2), a byproduct of the LSD1-catalyzed demethylation reaction.[\[13\]](#)

Principle: LSD1-mediated demethylation of a methylated histone peptide substrate produces H_2O_2 . In the presence of HRP, the H_2O_2 oxidizes a chromogenic substrate (e.g., Amplex Red or a mixture of 4-aminoantipyrine and 3,5-dichloro-2-hydroxybenzenesulfonate), leading to the formation of a colored product that can be measured spectrophotometrically.[\[13\]](#)

Protocol:

- Reagent Preparation:
 - Prepare a reaction mixture containing assay buffer, HRP, the chromogenic substrate, and the methylated H3 peptide substrate.
 - Prepare LSD1 enzyme dilution in assay buffer.
 - Prepare inhibitor solutions at various concentrations.
- Enzymatic Reaction and Detection:
 - Add the inhibitor or vehicle control to the wells of a 96-well plate.
 - Add the reaction mixture to the wells.
 - Initiate the reaction by adding the LSD1 enzyme solution.
 - Immediately place the plate in a spectrophotometer pre-set to the appropriate wavelength (e.g., 571 nm for Amplex Red).
 - Monitor the increase in absorbance over time.

- Data Analysis:
 - Calculate the initial reaction velocity from the linear portion of the absorbance curve.
 - Plot the reaction velocity against the inhibitor concentration and fit the data to determine the IC50 value.

Cell-Based Assays

This assay determines the effect of an LSD1 inhibitor on the proliferation and survival of cancer cells.

Principle: Various methods can be employed, such as MTT or CellTiter-Glo assays. The CellTiter-Glo Luminescent Cell Viability Assay measures the amount of ATP present, which is an indicator of metabolically active cells.

Protocol (using CellTiter-Glo):

- Cell Seeding:
 - Seed cancer cells in a 96-well plate at a predetermined density and allow them to adhere overnight.
- Compound Treatment:
 - Treat the cells with a serial dilution of the LSD1 inhibitor or vehicle control.
 - Incubate the cells for a specified period (e.g., 72 hours).
- Lysis and Luminescence Measurement:
 - Equilibrate the plate and the CellTiter-Glo reagent to room temperature.
 - Add CellTiter-Glo reagent to each well according to the manufacturer's instructions.
 - Mix the contents on an orbital shaker for 2 minutes to induce cell lysis.
 - Incubate at room temperature for 10 minutes to stabilize the luminescent signal.

- Measure the luminescence using a microplate reader.
- Data Analysis:
 - Normalize the luminescence readings to the vehicle-treated control.
 - Plot the percentage of cell viability against the inhibitor concentration to determine the IC50 value.

ChIP is used to determine the occupancy of LSD1 at specific genomic loci and the effect of inhibitors on this binding and on histone methylation marks.[\[14\]](#)

Principle: Cells are treated with a cross-linking agent to fix protein-DNA interactions. The chromatin is then sheared, and an antibody specific to the protein of interest (e.g., LSD1) or a specific histone modification (e.g., H3K4me2) is used to immunoprecipitate the protein-DNA complexes. The associated DNA is then purified and analyzed by qPCR or sequencing.

Protocol:

- Cell Treatment and Cross-linking:
 - Treat cells with the LSD1 inhibitor or vehicle control for the desired time.
 - Add formaldehyde directly to the culture medium to a final concentration of 1% and incubate for 10 minutes at room temperature to cross-link proteins to DNA.
 - Quench the cross-linking reaction by adding glycine.
- Cell Lysis and Chromatin Shearing:
 - Harvest and lyse the cells to isolate the nuclei.
 - Resuspend the nuclei in a lysis buffer and shear the chromatin to fragments of 200-1000 bp using sonication or enzymatic digestion.
- Immunoprecipitation:
 - Pre-clear the chromatin with protein A/G agarose/magnetic beads.

- Incubate the pre-cleared chromatin with an antibody against LSD1 or the histone mark of interest overnight at 4°C.
- Add protein A/G beads to capture the antibody-protein-DNA complexes.
- Washing and Elution:
 - Wash the beads sequentially with low salt, high salt, LiCl, and TE buffers to remove non-specific binding.
 - Elute the protein-DNA complexes from the beads.
- Reverse Cross-linking and DNA Purification:
 - Reverse the protein-DNA cross-links by incubating at 65°C overnight with NaCl.
 - Treat with RNase A and Proteinase K to remove RNA and protein.
 - Purify the DNA using a PCR purification kit or phenol-chloroform extraction.
- Analysis:
 - Quantify the amount of precipitated DNA corresponding to specific gene promoters or enhancers using quantitative real-time PCR (qPCR) with specific primers.

Signaling Pathways and Molecular Interactions

LSD1 and LSD2 are involved in a multitude of cellular signaling pathways, often in a context-dependent manner. The following diagrams, generated using the DOT language for Graphviz, illustrate some of the key pathways influenced by these demethylases.

LSD1 in the Wnt/ β -catenin Signaling Pathway

LSD1 has been shown to regulate the Wnt/ β -catenin pathway, a critical signaling cascade in development and disease.^{[15][16][17][18]} LSD1 can demethylate and stabilize β -catenin, preventing its degradation and thereby promoting its nuclear translocation and transcriptional activity.^{[15][16][18]} Additionally, LSD1 can repress the expression of Wnt pathway antagonists like DKK1.^[17]

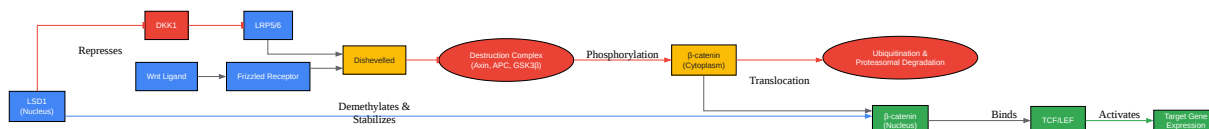

[Click to download full resolution via product page](#)

Caption: LSD1 positively regulates Wnt/ β -catenin signaling.

LSD1 in the Notch Signaling Pathway

LSD1 can act as a transcriptional repressor of Notch pathway genes. Inhibition of LSD1 leads to the upregulation of Notch receptors and downstream signaling, which can have anti-proliferative effects in certain cancers like small cell lung cancer.[14][19]

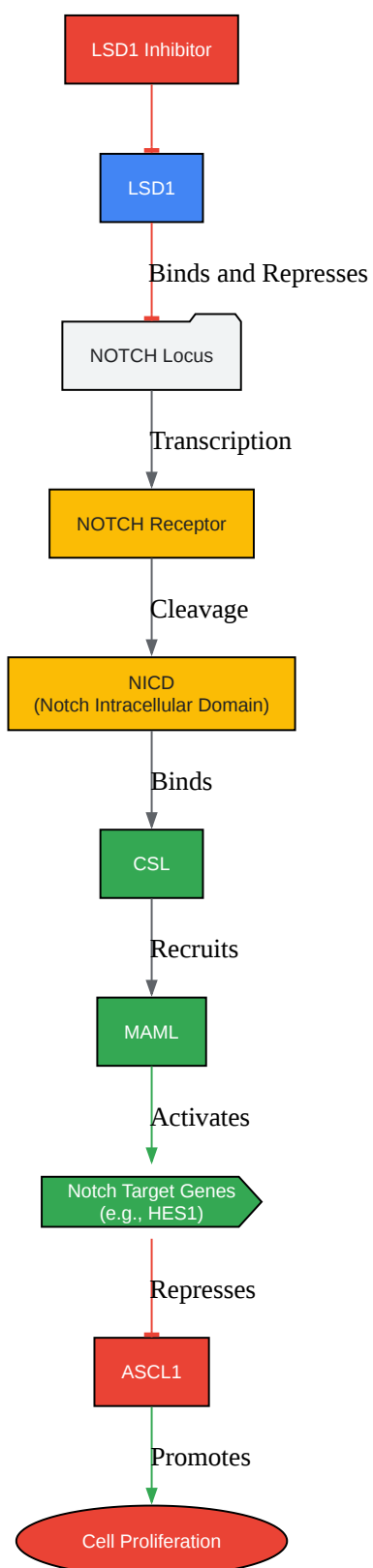

[Click to download full resolution via product page](#)

Caption: LSD1 inhibition activates Notch signaling.

LSD1 in the PI3K/Akt/mTOR Signaling Pathway

LSD1 can positively regulate the PI3K/Akt/mTOR pathway, a key cascade involved in cell growth, proliferation, and survival.^{[20][21][22][23]} This regulation can occur through the transcriptional control of pathway components like the p85 regulatory subunit of PI3K.^[21]

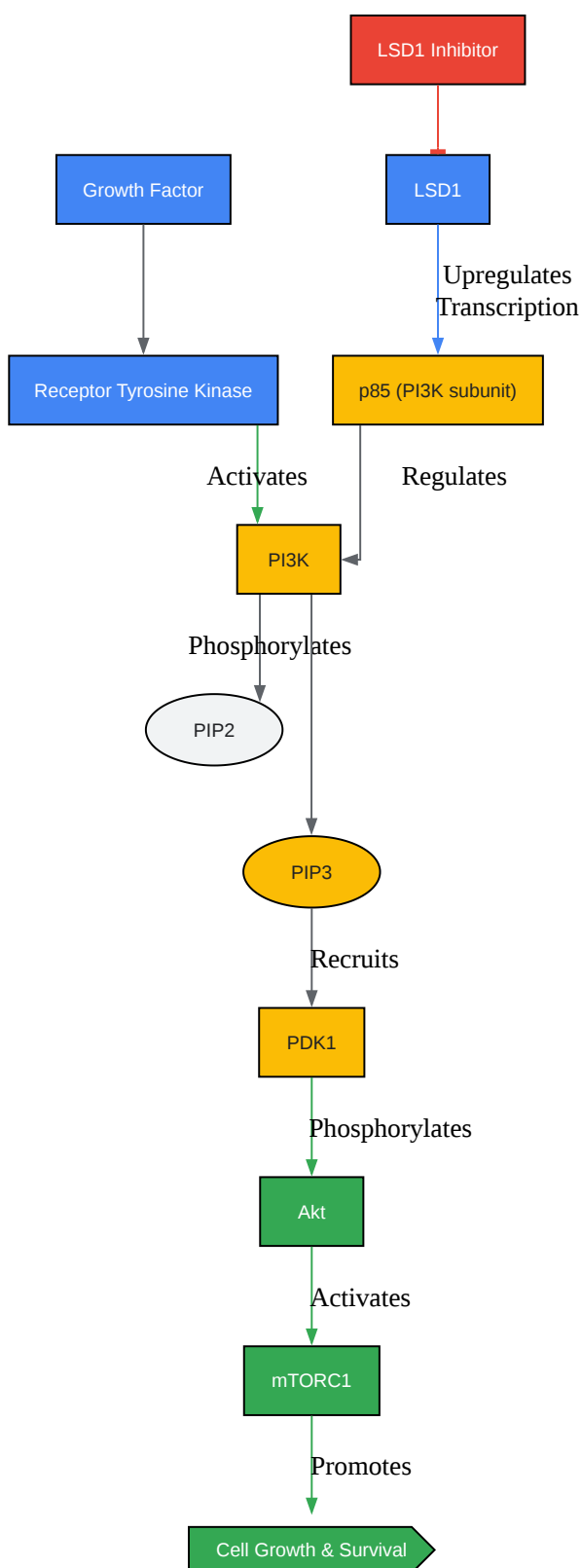

[Click to download full resolution via product page](#)

Caption: LSD1 promotes PI3K/Akt/mTOR signaling.

LSD2 in Metabolic Regulation

LSD2 has been implicated in the regulation of metabolic processes, including lipid metabolism. In *Drosophila*, the LSD2 homolog is involved in lipid storage and homeostasis.[24][25][26] In mammalian cells, LSD2 can modulate the expression of gluconeogenic enzymes.[27]

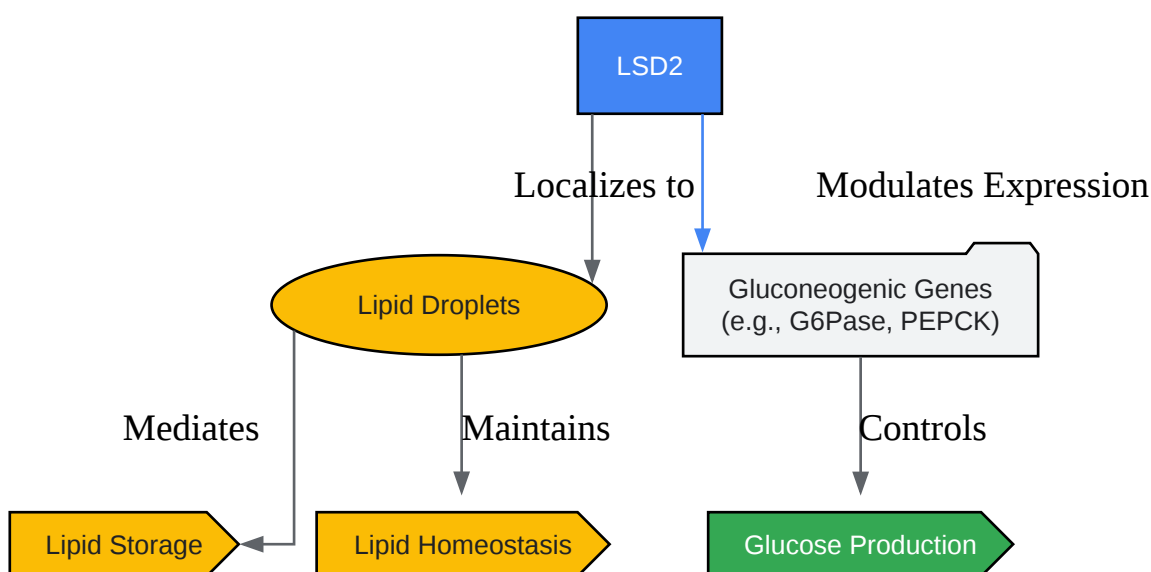

[Click to download full resolution via product page](#)

Caption: LSD2 plays a role in metabolic regulation.

Conclusion and Future Directions

Lsd1-IN-22 represents a potent tool for the chemical-biological investigation of LSD1. The distinct and sometimes overlapping functions of LSD1 and its paralog LSD2 underscore the complexity of epigenetic regulation. The development of highly selective inhibitors for each paralog remains a critical goal to dissect their individual contributions to cellular processes and to develop more targeted therapeutic strategies. The detailed protocols and pathway diagrams provided in this guide are intended to facilitate further research into the fascinating biology of these enzymes and the therapeutic potential of their inhibitors. Future work will likely focus on understanding the non-catalytic scaffolding functions of LSD1 and LSD2, identifying novel substrates, and exploring combination therapies that leverage the epigenetic vulnerabilities created by LSD1/LSD2 inhibition.

Need Custom Synthesis?

BenchChem offers custom synthesis for rare earth carbides and specific isotopic labeling.

Email: info@benchchem.com or [Request Quote Online](#).

References

- 1. LSD1: biologic roles and therapeutic targeting - PMC [[pmc.ncbi.nlm.nih.gov](https://pubmed.ncbi.nlm.nih.gov/)]
- 2. mdpi.com [mdpi.com]
- 3. researchgate.net [researchgate.net]
- 4. researchgate.net [researchgate.net]
- 5. The LSD1 inhibitor iadademstat (ORY-1001) targets SOX2-driven breast cancer stem cells: a potential epigenetic therapy in luminal-B and HER2-positive breast cancer subtypes - PMC [[pmc.ncbi.nlm.nih.gov](https://pubmed.ncbi.nlm.nih.gov/)]
- 6. iris.uniroma1.it [iris.uniroma1.it]
- 7. LSD1 inhibitors for cancer treatment: Focus on multi-target agents and compounds in clinical trials - PMC [[pmc.ncbi.nlm.nih.gov](https://pubmed.ncbi.nlm.nih.gov/)]
- 8. caymanchem.com [caymanchem.com]
- 9. moleculardevices.com [moleculardevices.com]
- 10. Anticancer Drugs of Lysine Specific Histone Demethylase-1 (LSD1) Display Variable Inhibition on Nucleosome Substrates - PMC [[pmc.ncbi.nlm.nih.gov](https://pubmed.ncbi.nlm.nih.gov/)]
- 11. TCP-based LSD1 inhibitors show potent anticancer activity in preclinical models | BioWorld [bioworld.com]
- 12. Comprehensive in Vitro Characterization of the LSD1 Small Molecule Inhibitor Class in Oncology - PMC [[pmc.ncbi.nlm.nih.gov](https://pubmed.ncbi.nlm.nih.gov/)]
- 13. LSD1 Histone Demethylase Assays and Inhibition - PMC [[pmc.ncbi.nlm.nih.gov](https://pubmed.ncbi.nlm.nih.gov/)]
- 14. LSD1 inhibition makes a NOTCH in SCLC | Fred Hutchinson Cancer Center [fredhutch.org]
- 15. biorxiv.org [biorxiv.org]
- 16. LSD1 controls a nuclear checkpoint in Wnt/ β -Catenin signaling to regulate muscle stem cell self-renewal - PMC [[pmc.ncbi.nlm.nih.gov](https://pubmed.ncbi.nlm.nih.gov/)]
- 17. researchgate.net [researchgate.net]

- 18. LSD1 controls a nuclear checkpoint in Wnt/ β -Catenin signaling to regulate muscle stem cell self-renewal - PubMed [pubmed.ncbi.nlm.nih.gov]
- 19. mdanderson.elsevierpure.com [mdanderson.elsevierpure.com]
- 20. LSD1 regulates Notch and PI3K/Akt/mTOR pathways through binding the promoter regions of Notch target genes in esophageal squamous cell carcinoma - PMC [pmc.ncbi.nlm.nih.gov]
- 21. LSD1 Activates PI3K/AKT Signaling Through Regulating p85 Expression in Prostate Cancer Cells - PMC [pmc.ncbi.nlm.nih.gov]
- 22. [PDF] LSD1 regulates Notch and PI3K/Akt/mTOR pathways through binding the promoter regions of Notch target genes in esophageal squamous cell carcinoma | Semantic Scholar [semanticscholar.org]
- 23. LSD1 regulates Notch and PI3K/Akt/mTOR pathways through binding the promoter regions of Notch target genes in esophageal squamous cell carcinoma - PubMed [pubmed.ncbi.nlm.nih.gov]
- 24. Regulation of lipid-droplet transport by the perilipin homolog LSD2 - PubMed [pubmed.ncbi.nlm.nih.gov]
- 25. Drosophila Perilipin/ADRP homologue Lsd2 regulates lipid metabolism - PubMed [pubmed.ncbi.nlm.nih.gov]
- 26. Drosophila Lipid Storage Droplet 2 gene (Lsd-2) is expressed and controls lipid storage in wing imaginal discs - PubMed [pubmed.ncbi.nlm.nih.gov]
- 27. researchgate.net [researchgate.net]
- To cite this document: BenchChem. [An In-depth Technical Guide to Lsd1-IN-22 and its Paralog LSD2]. BenchChem, [2026]. [Online PDF]. Available at: [<https://www.benchchem.com/product/b12397650/docs#an-in-depth-technical-guide-to-lsd1-in-22-and-its-paralog-lsd2>]

Disclaimer & Data Validity:

The information provided in this document is for Research Use Only (RUO) and is strictly not intended for diagnostic or therapeutic procedures. While BenchChem strives to provide accurate protocols, we make no warranties, express or implied, regarding the fitness of this product for every specific experimental setup.

Technical Support: The protocols provided are for reference purposes. Unsure if this reagent suits your experiment?

Need Industrial/Bulk Grade? [Request Custom Synthesis Quote](#)

BenchChem

Our mission is to be the trusted global source of essential and advanced chemicals, empowering scientists and researchers to drive progress in science and industry.

Contact

Address: 3281 E Guasti Rd
Ontario, CA 91761, United States
Phone: (601) 213-4426
Email: info@benchchem.com

[Contact our Ph.D. Support Team for a compatibility check](#)