

A Comparative Analysis of Protein Kinase CK2 Inhibitor Potency

Author: BenchChem Technical Support Team. **Date:** April 2026

Compound of Interest

Compound Name: CK2-IN-3
Cat. No.: B12397843

Get Quote

For Researchers, Scientists, and Drug Development Professionals

Protein kinase CK2 is a constitutively active serine/threonine kinase that plays a critical role in a wide array of cellular processes, including cell growth, proliferation, and survival.^{[1][2]} Its dysregulation is implicated in various diseases, particularly cancer, making it an attractive therapeutic target.^{[3][4]} This guide provides a comparative analysis of the potency of several prominent CK2 inhibitors, supported by experimental data and detailed methodologies.

Potency of CK2 Inhibitors: A Comparative Overview

The development of CK2 inhibitors has led to a range of compounds with varying potencies and specificities. The most common metrics for inhibitor potency are the half-maximal inhibitory concentration (IC₅₀) and the inhibition constant (K_i). The table below summarizes these values for several well-characterized CK2 inhibitors.

Inhibitor	Type	IC50	Ki	Notes
CX-4945 (Silmintasertib)	ATP-competitive	0.7 - 3.8 nM (CK2 α)	0.223 nM	Orally bioavailable, in clinical trials.[5] [6] Also inhibits other kinases like CLK2.[7]
SGC-CK2-1	ATP-competitive	4.2 nM (CK2 α), 2.3 nM (CK2 α')	Not specified	High potency.
SGC-CK2-2	ATP-competitive	920 nM (NanoBRET)	Not specified	Derivative of CX-4945 with enhanced specificity but reduced potency. [8][9]
GO289	ATP-competitive	Not specified	Not specified	Reported to have higher inhibitory efficacy than CX-4945 in cellular assays.[10]
TBB (4,5,6,7-Tetrabromobenzotriazole)	ATP-competitive	Not specified	Not specified	A polyhalogenated benzimidazole derivative.
Ellagic Acid	ATP-competitive	Not specified	0.020 μ M	A natural compound identified through virtual screening. [11]
NBC (Naphtho[2,3-b]furan-4,9-dione)	Dual CK2/PIM inhibitor	0.37 μ M (CK2)	0.22 μ M (CK2)	Also inhibits PIM-1 and PIM-3 kinases.[7]

Note: IC50 and Ki values can vary depending on the experimental conditions, such as ATP concentration and the specific CK2 isoform used.

Experimental Protocols

The determination of CK2 inhibitor potency relies on robust and reproducible experimental assays. Below are detailed methodologies for common in vitro and cellular assays.

In Vitro CK2 Kinase Inhibition Assay (Radiometric)

This traditional method measures the incorporation of radiolabeled phosphate into a specific CK2 substrate.

Materials:

- Purified recombinant CK2 enzyme (α or holoenzyme)
- CK2-specific peptide substrate (e.g., RRRADDSDDDDDD)
- [γ - 32 P]ATP
- Kinase reaction buffer (e.g., 25 mM Tris-HCl pH 7.5, 10 mM MgCl₂, 1 mM DTT)
- Inhibitor compounds dissolved in DMSO
- P81 phosphocellulose paper
- Phosphoric acid
- Scintillation counter

Procedure:

- Prepare a reaction mixture containing kinase buffer, purified CK2 enzyme, and the specific peptide substrate.
- Add the inhibitor compound at various concentrations (or DMSO as a vehicle control) to the reaction mixture and pre-incubate for 10-15 minutes at room temperature.

- Initiate the kinase reaction by adding [γ - ^{32}P]ATP.
- Incubate the reaction at 30°C for a defined period (e.g., 10-30 minutes), ensuring the reaction stays within the linear range.
- Stop the reaction by spotting a portion of the reaction mixture onto P81 phosphocellulose paper.
- Wash the P81 paper extensively with phosphoric acid to remove unincorporated [γ - ^{32}P]ATP.
- Quantify the incorporated radioactivity on the P81 paper using a scintillation counter.
- Calculate the percentage of inhibition for each inhibitor concentration relative to the DMSO control and determine the IC50 value by non-linear regression analysis.

Cellular CK2 Activity Assay

This assay assesses the ability of an inhibitor to block CK2 activity within a cellular context by measuring the phosphorylation of a known intracellular CK2 substrate.

Materials:

- Cell line of interest (e.g., HeLa, U373)
- Cell culture medium and reagents
- Inhibitor compounds
- Lysis buffer (e.g., RIPA buffer with protease and phosphatase inhibitors)
- Antibodies:
 - Primary antibody against a phosphorylated CK2 substrate (e.g., anti-phospho-Cdc37 (Ser13))
 - Primary antibody against the total protein of the substrate (e.g., anti-Cdc37)
 - Loading control antibody (e.g., anti-GAPDH)

- Secondary antibody conjugated to HRP or a fluorescent dye
- SDS-PAGE and Western blotting equipment and reagents

Procedure:

- Seed cells in multi-well plates and allow them to adhere overnight.
- Treat the cells with increasing concentrations of the CK2 inhibitor (and a DMSO control) for a specified duration (e.g., 24 or 48 hours).[12]
- Wash the cells with ice-cold PBS and lyse them using lysis buffer.
- Determine the protein concentration of the cell lysates.
- Separate equal amounts of protein from each sample by SDS-PAGE and transfer to a PVDF or nitrocellulose membrane.
- Block the membrane and probe with the primary antibody against the phosphorylated CK2 substrate.
- Wash the membrane and incubate with the appropriate secondary antibody.
- Detect the signal using a suitable detection reagent (e.g., ECL for HRP).
- Strip the membrane (if necessary) and re-probe with antibodies for the total substrate protein and a loading control to normalize the data.
- Quantify the band intensities and calculate the reduction in phosphorylation of the CK2 substrate as a measure of cellular CK2 inhibition.

Visualizing CK2's Role and Inhibition

CK2 Signaling Pathways

CK2 is a highly pleiotropic kinase that phosphorylates hundreds of substrates, thereby influencing numerous signaling pathways critical for cell survival and proliferation.[3][4] Key pathways regulated by CK2 include PI3K/AKT/mTOR, NF-κB, and JAK/STAT.[2]

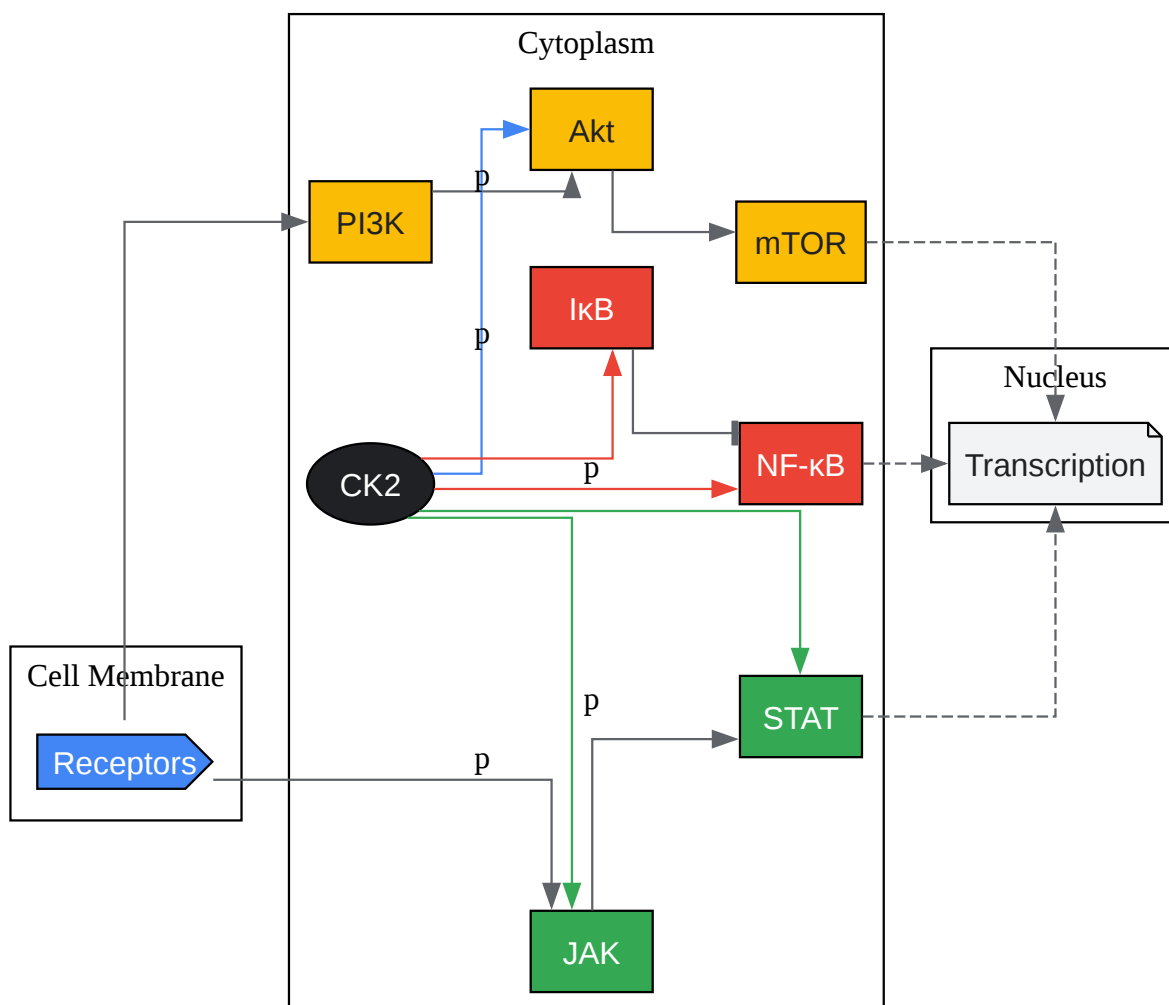

[Click to download full resolution via product page](#)

Caption: Key signaling pathways modulated by Protein Kinase CK2.

Experimental Workflow for CK2 Inhibitor Screening

The process of identifying and characterizing CK2 inhibitors follows a logical workflow, from initial screening to cellular validation.

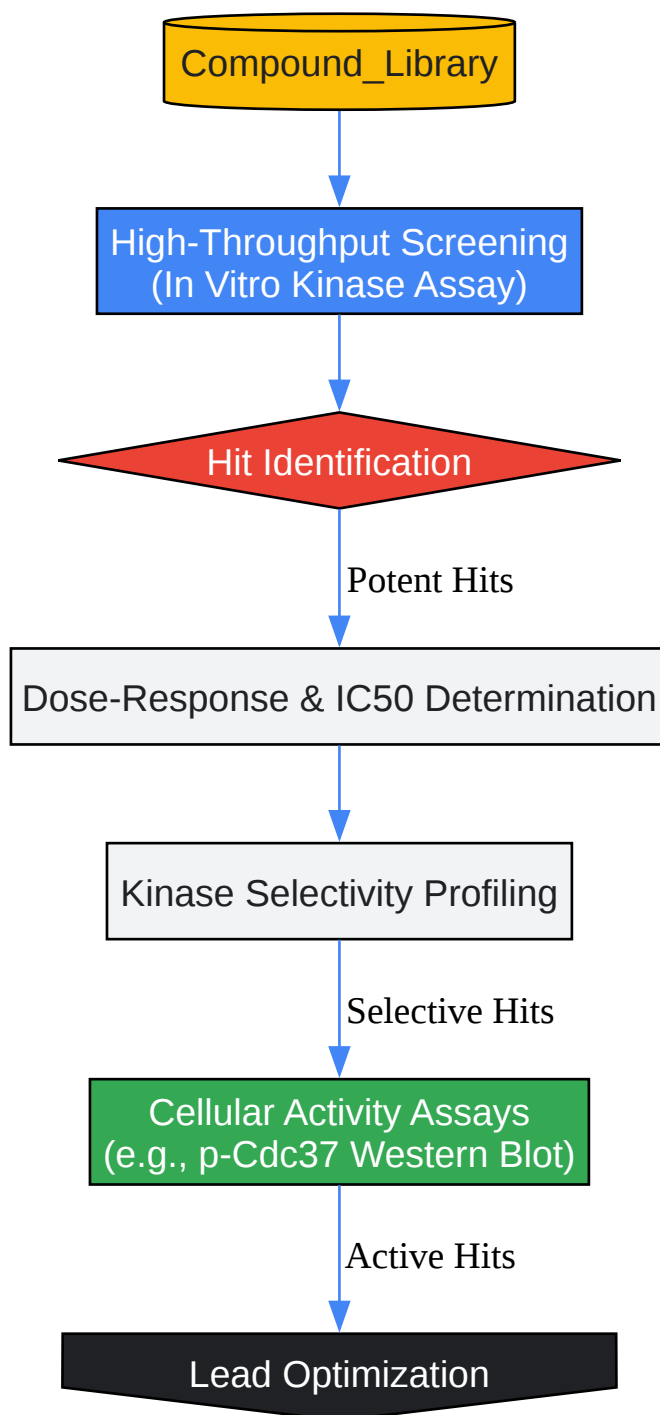

[Click to download full resolution via product page](#)

Caption: Workflow for the discovery and validation of CK2 inhibitors.

Need Custom Synthesis?

BenchChem offers custom synthesis for rare earth carbides and specific isotopic labeling.

Email: info@benchchem.com or [Request Quote Online](#).

References

- 1. Protein kinase CK2 in health and disease: CK2 and its role in Wnt and NF-kappaB signaling: linking development and cancer - PubMed [pubmed.ncbi.nlm.nih.gov]
- 2. [researchgate.net](https://www.researchgate.net) [[researchgate.net](https://www.researchgate.net)]
- 3. Protein kinase CK2: a potential therapeutic target for diverse human diseases - PMC [[pmc.ncbi.nlm.nih.gov](https://pubmed.ncbi.nlm.nih.gov)]
- 4. Frontiers | Protein Kinase CK2 in Cancer Energetics [[frontiersin.org](https://www.frontiersin.org)]
- 5. Recent Advances in the Discovery of CK2 Inhibitors - PMC [[pmc.ncbi.nlm.nih.gov](https://pubmed.ncbi.nlm.nih.gov)]
- 6. What are CK2 inhibitors and how do they work? [synapse.patsnap.com]
- 7. [mdpi.com](https://www.mdpi.com) [[mdpi.com](https://www.mdpi.com)]
- 8. Comparative Efficacy of CK2 Inhibitors CX-4945 and SGC-CK2-2 on CK2 Signaling - PubMed [pubmed.ncbi.nlm.nih.gov]
- 9. [mdpi.com](https://www.mdpi.com) [[mdpi.com](https://www.mdpi.com)]
- 10. Comparing the efficacy and selectivity of Ck2 inhibitors. A phosphoproteomics approach - PubMed [pubmed.ncbi.nlm.nih.gov]
- 11. [mdpi.com](https://www.mdpi.com) [[mdpi.com](https://www.mdpi.com)]
- 12. Antitumoral activity of allosteric inhibitors of protein kinase CK2 - PMC [[pmc.ncbi.nlm.nih.gov](https://pubmed.ncbi.nlm.nih.gov)]
- To cite this document: BenchChem. [A Comparative Analysis of Protein Kinase CK2 Inhibitor Potency]. BenchChem, [2026]. [Online PDF]. Available at: [<https://www.benchchem.com/product/b12397843/docs#a-comparative-analysis-of-protein-kinase-ck2-inhibitor-potency>]

Disclaimer & Data Validity:

The information provided in this document is for Research Use Only (RUO) and is strictly not intended for diagnostic or therapeutic procedures. While BenchChem strives to provide accurate protocols, we make no warranties, express or implied, regarding the fitness of this product for every specific experimental setup.

Technical Support: The protocols provided are for reference purposes. Unsure if this reagent suits your experiment?

Need Industrial/Bulk Grade? [Request Custom Synthesis Quote](#)

BenchChem

Our mission is to be the trusted global source of essential and advanced chemicals, empowering scientists and researchers to drive progress in science and industry.

Contact

Address: 3281 E Guasti Rd
Ontario, CA 91761, United States
Phone: (601) 213-4426
Email: info@benchchem.com

[Contact our Ph.D. Support Team for a compatibility check](#)