

# Technical Support Center: Overcoming FGFR Inhibitor Resistance with LC-MB12

**Author:** BenchChem Technical Support Team. **Date:** April 2026

## Compound of Interest

Compound Name: LC-MB12  
Cat. No.: B12396849

[Get Quote](#)

Welcome to the technical support center for **LC-MB12**, a selective, orally bioavailable FGFR2 PROTAC (Proteolysis Targeting Chimera) degrader. This resource is designed for researchers, scientists, and drug development professionals to provide troubleshooting guidance and frequently asked questions (FAQs) regarding the use of **LC-MB12**, particularly in the context of overcoming resistance to conventional FGFR inhibitors.

## Frequently Asked Questions (FAQs)

Q1: What is **LC-MB12** and how does it differ from traditional FGFR inhibitors?

A1: **LC-MB12** is a proteolysis-targeting chimera (PROTAC) that selectively induces the degradation of the FGFR2 protein.<sup>[1][2]</sup> It is not a direct inhibitor in the traditional sense. **LC-MB12** is a heterobifunctional molecule composed of a ligand that binds to FGFR2 (based on the pan-FGFR inhibitor BGJ398), a linker, and a ligand that recruits the Cereblon (CRBN) E3 ubiquitin ligase.<sup>[1]</sup> Upon binding to both FGFR2 and CRBN, **LC-MB12** facilitates the ubiquitination of FGFR2, marking it for degradation by the proteasome. This mechanism of action, which eliminates the entire protein, is distinct from traditional FGFR inhibitors that merely block the kinase activity.<sup>[2][3]</sup>

Q2: What are the common mechanisms of acquired resistance to FGFR inhibitors?

A2: Acquired resistance to FGFR inhibitors is a significant clinical challenge. The most common mechanisms include:

- On-target secondary mutations in the FGFR2 kinase domain. The most frequently observed mutations occur at the "molecular brake" residue (N550) and the "gatekeeper" residue (V565).[4][5][6] These mutations can prevent the inhibitor from binding effectively while preserving the kinase activity of the receptor.
- Activation of bypass signaling pathways, such as the PI3K/mTOR and MAPK pathways, which can sustain downstream signaling even when FGFR2 is inhibited.

Q3: Can **LC-MB12** overcome resistance caused by FGFR2 kinase domain mutations (e.g., N550K, V565F)?

A3: Theoretically, as a PROTAC degrader, **LC-MB12** may have the potential to overcome resistance mediated by kinase domain mutations. The rationale is that as long as the FGFR2-binding portion of **LC-MB12** can still bind to the mutated FGFR2 protein, even with reduced affinity, it can still bring the E3 ligase in proximity to tag the protein for degradation. By removing the entire protein, resistance conferred by mutations that prevent inhibitor-mediated kinase inactivation becomes irrelevant. However, it is important to note that currently, there is no publicly available data specifically demonstrating the efficacy of **LC-MB12** against known FGFR2 resistance mutations. Experimental validation is required to confirm this hypothesis.

Q4: What is the selectivity profile of **LC-MB12**?

A4: **LC-MB12** has been shown to preferentially degrade the membrane-bound form of FGFR2 over other FGFR isoforms (FGFR1, 3, and 4), despite its parental inhibitor (BGJ398) being a pan-FGFR inhibitor.[2][3] This suggests that the ternary complex formation required for degradation is more efficient with FGFR2.

## Troubleshooting Guide

| Issue/Observation   | Possible Cause(s)   | Suggested Solution(s)   |
|---|---|---|
| <p>No FGFR2 degradation observed after LC-MB12 treatment.</p>                             | <p>1. Sub-optimal concentration or treatment time. 2. Low expression of CRBN E3 ligase in the cell model. 3. Cell line is not dependent on FGFR2 signaling. 4. Issues with LC-MB12 compound integrity.</p>                                | <p>1. Perform a dose-response (e.g., 1 nM to 10 μM) and time-course (e.g., 2, 4, 8, 12, 24 hours) experiment to determine optimal degradation conditions. 2. Verify CRBN expression in your cell line by Western blot or qPCR. If low, consider using a different cell model. 3. Confirm FGFR2 expression and pathway activation (p-FRS2, p-ERK) at baseline. 4. Verify the quality and stability of the LC-MB12 compound.</p>                          |
| <p>Cell line resistant to a conventional FGFR inhibitor shows no response to LC-MB12.</p> | <p>1. The specific FGFR2 mutation in the resistant cell line prevents LC-MB12 binding. 2. Resistance is driven by a bypass pathway that is independent of FGFR2. 3. Insufficient degradation of FGFR2 is achieved at tolerable doses.</p> | <p>1. Sequence the FGFR2 kinase domain in your resistant cell line to identify mutations. Test a higher concentration of LC-MB12, but be mindful of off-target effects. 2. Perform pathway analysis (e.g., phospho-RTK array, Western blots for p-AKT, p-mTOR) to investigate bypass pathway activation. 3. Confirm FGFR2 degradation via Western blot. If degradation is incomplete, the remaining FGFR2 may be sufficient to drive proliferation.</p> |

|  |   |  |
|--|---|--|
| <p>High background or off-target effects observed.</p> | <p>1. LC-MB12 concentration is too high. 2. The parental inhibitor (BGJ398) has off-target activities at high concentrations.</p> | <p>1. Use the lowest effective concentration of LC-MB12 that achieves maximal FGFR2 degradation (DC<sub>max</sub>). 2. Compare the phenotype observed with LC-MB12 to that of BGJ398 at the same concentrations to distinguish between degradation-mediated and inhibition-mediated effects.</p> |
|--|---|--|

## Data Presentation

Table 1: In Vitro Activity of **LC-MB12** in FGFR2-Amplified Gastric Cancer Cell Lines<sup>[1]</sup>

| Cell Line | LC-MB12 DC <sub>50</sub> (nM) <sup>1</sup> | LC-MB12 IC <sub>50</sub> (nM) <sup>2</sup> |
|-----------|--|--|
| KATO III  | 11.8                                       | 29.1                                       |
| SNU-16    | Not Reported                               | 3.7  |
| NCI-H716  | Not Reported                               | 3.2  |

<sup>1</sup> DC<sub>50</sub>: Half-maximal degradation concentration. <sup>2</sup> IC<sub>50</sub>: Half-maximal inhibitory concentration for cell growth after 72 hours.

Table 2: In Vivo Antitumor Activity of **LC-MB12**<sup>[1]</sup>

| Xenograft Model | Treatment                    | Tumor Growth Inhibition (%) |
|-----------------|------------------------------|-----------------------------|
| SNU-16          | LC-MB12 (20 mg/kg/day, p.o.) | 63.1                        |

## Experimental Protocols

Protocol 1: Assessing FGFR2 Degradation by Western Blot

- Cell Culture and Treatment: Plate FGFR2-dependent cells (e.g., KATO III, SNU-16) and allow them to adhere overnight. Treat cells with a range of **LC-MB12** concentrations (e.g., 1, 10, 100, 1000 nM) and a vehicle control (e.g., 0.1% DMSO) for a specified time (e.g., 8 hours).
- Cell Lysis: Wash cells with ice-cold PBS and lyse with RIPA buffer containing protease and phosphatase inhibitors.
- Protein Quantification: Determine the protein concentration of each lysate using a BCA assay.
- Western Blotting:
  - Load equal amounts of protein (e.g., 20-30 µg) onto an SDS-PAGE gel.
  - Transfer proteins to a PVDF membrane.
  - Block the membrane with 5% non-fat milk or BSA in TBST for 1 hour.
  - Incubate with primary antibodies overnight at 4°C (e.g., anti-FGFR2, anti-p-FRS2, anti-p-ERK, anti-CRBN, and a loading control like anti-GAPDH or anti-β-actin).
  - Wash the membrane and incubate with HRP-conjugated secondary antibodies for 1 hour at room temperature.
  - Visualize bands using an ECL substrate and an imaging system.
- Analysis: Quantify band intensity and normalize FGFR2 levels to the loading control. Compare levels in **LC-MB12**-treated samples to the vehicle control to determine the percentage of degradation.

#### Protocol 2: Evaluating Proliferation in FGFR Inhibitor-Resistant Cells

- Cell Line Generation (if necessary): Generate resistant cell lines by long-term culture of an FGFR2-dependent cell line with an increasing concentration of a conventional FGFR inhibitor (e.g., pemigatinib, infigratinib). Confirm resistance by comparing the IC<sub>50</sub> of the resistant line to the parental line.

- Cell Seeding: Seed both parental and resistant cells in 96-well plates at an appropriate density.
- Treatment: Treat cells with serial dilutions of **LC-MB12**, the conventional FGFR inhibitor (as a control), and a vehicle control.
- Viability Assay: After 72-96 hours of incubation, measure cell viability using a suitable assay (e.g., CellTiter-Glo®, MTS, or crystal violet).
- Data Analysis: Normalize the data to the vehicle-treated wells. Plot the dose-response curves and calculate the  $IC_{50}$  values for each compound in both the parental and resistant cell lines. A significant decrease in the  $IC_{50}$  for **LC-MB12** in the resistant line compared to the conventional inhibitor would suggest that **LC-MB12** can overcome the resistance mechanism.

## Visualizations

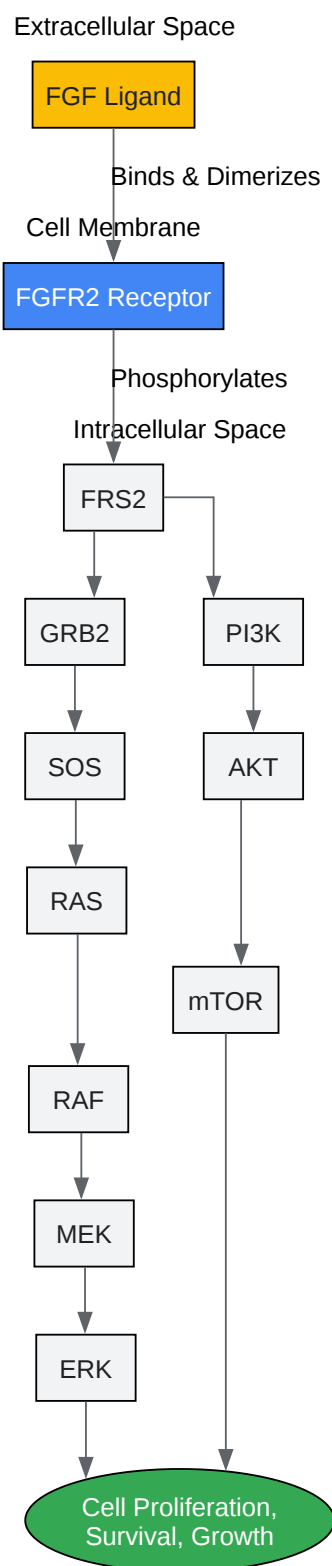

[Click to download full resolution via product page](#)

Caption: Canonical FGFR2 signaling pathway.

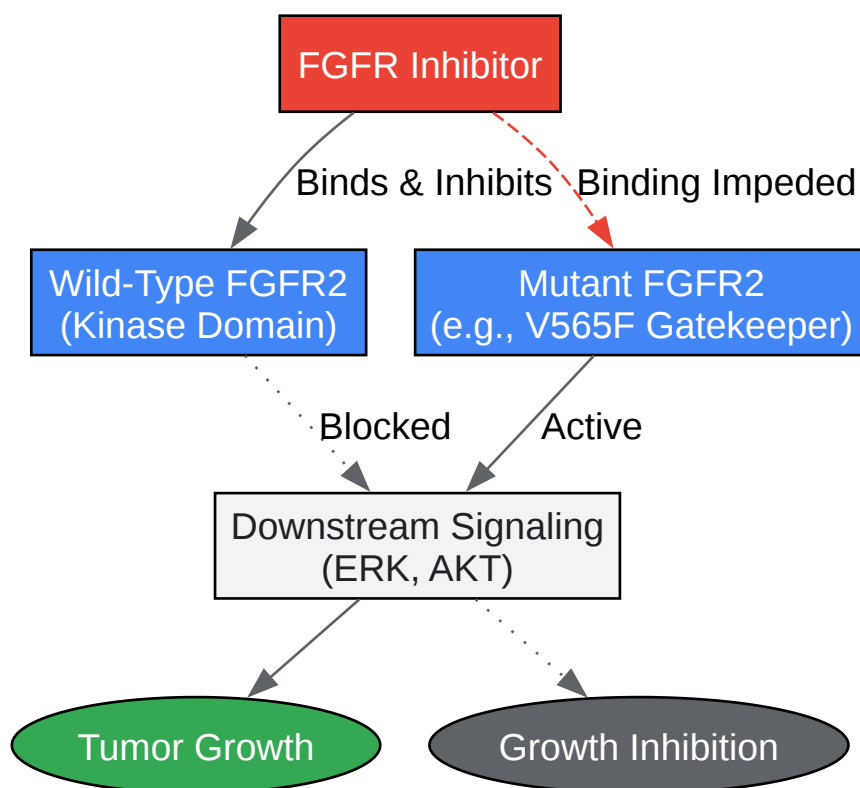

[Click to download full resolution via product page](#)

Caption: Resistance via FGFR2 gatekeeper mutation.

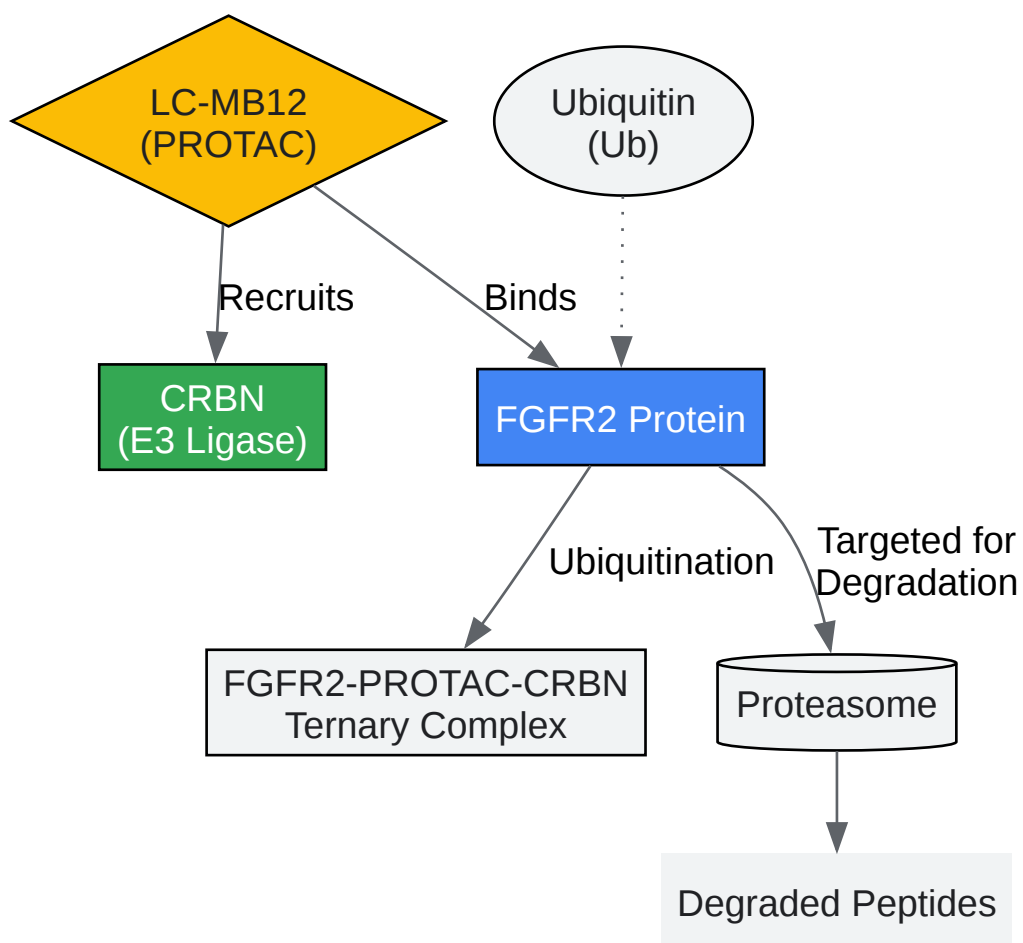

[Click to download full resolution via product page](#)

Caption: Mechanism of action of **LC-MB12**.

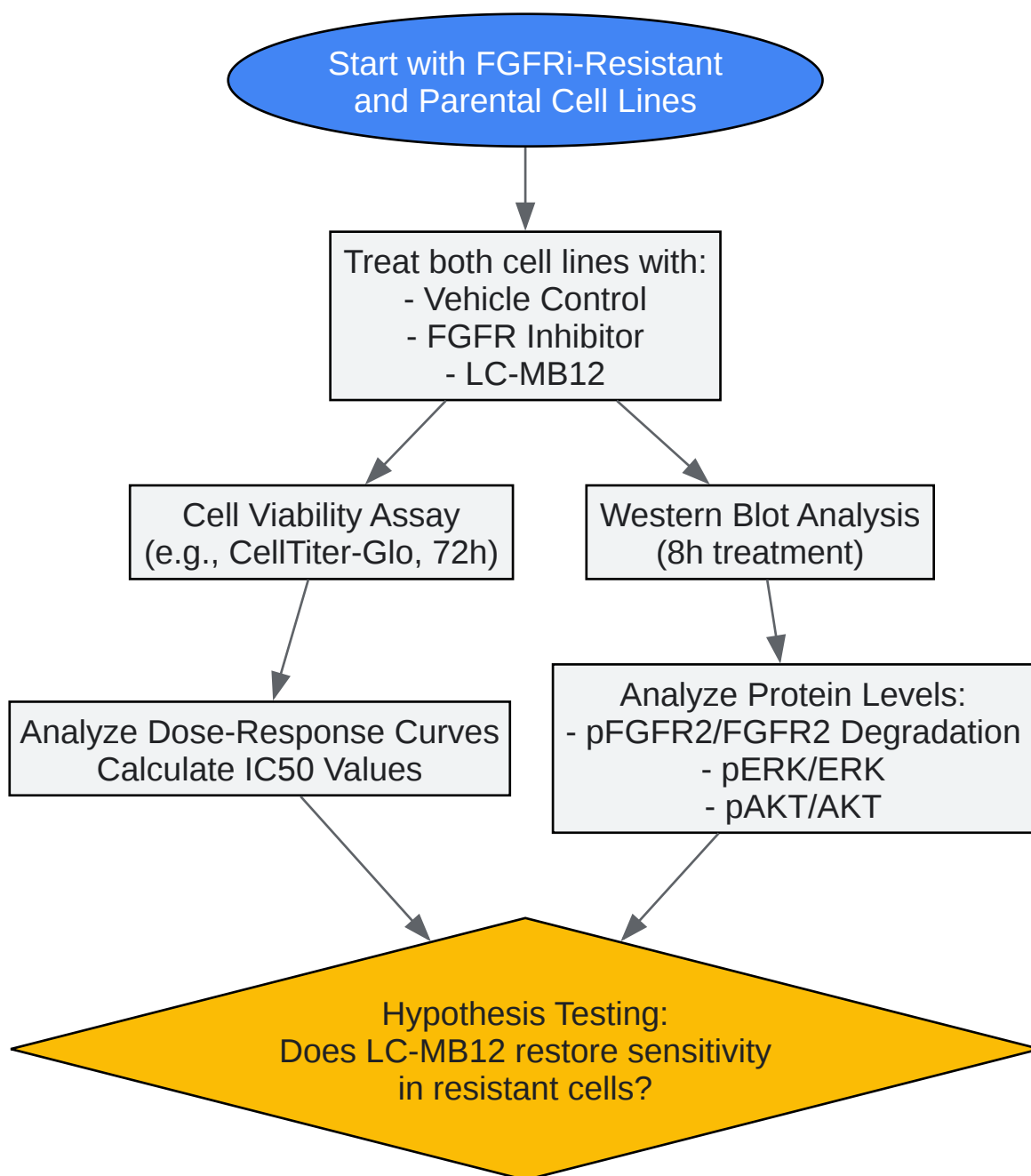

[Click to download full resolution via product page](#)

### Need Custom Synthesis?

BenchChem offers custom synthesis for rare earth carbides and specific isotopic labeling.

Email: [info@benchchem.com](mailto:info@benchchem.com) or [Request Quote Online](#).

## References

- [1. cancer-research-network.com \[cancer-research-network.com\]](https://cancer-research-network.com)
- [2. Discovery of a Selective and Orally Bioavailable FGFR2 Degradator for Treating Gastric Cancer \[pubmed.ncbi.nlm.nih.gov\]](https://pubmed.ncbi.nlm.nih.gov)
- [3. pubs.acs.org \[pubs.acs.org\]](https://pubs.acs.org)
- [4. researchgate.net \[researchgate.net\]](https://researchgate.net)
- [5. pubs.acs.org \[pubs.acs.org\]](https://pubs.acs.org)
- [6. Landscape of Clinical Resistance Mechanisms to FGFR Inhibitors in FGFR2-Altered Cholangiocarcinoma - PMC \[pmc.ncbi.nlm.nih.gov\]](https://pmc.ncbi.nlm.nih.gov)
- To cite this document: BenchChem. [Technical Support Center: Overcoming FGFR Inhibitor Resistance with LC-MB12]. BenchChem, [2026]. [Online PDF]. Available at: [\[https://www.benchchem.com/product/b12396849/docs#technical-support-center-overcoming-fgfr-inhibitor-resistance-with-lc-mb12\]](https://www.benchchem.com/product/b12396849/docs#technical-support-center-overcoming-fgfr-inhibitor-resistance-with-lc-mb12)

---

### Disclaimer & Data Validity:

The information provided in this document is for Research Use Only (RUO) and is strictly not intended for diagnostic or therapeutic procedures. While BenchChem strives to provide accurate protocols, we make no warranties, express or implied, regarding the fitness of this product for every specific experimental setup.

**Technical Support:** The protocols provided are for reference purposes. Unsure if this reagent suits your experiment?

**Need Industrial/Bulk Grade?** [Request Custom Synthesis Quote](#)

## BenchChem

Our mission is to be the trusted global source of essential and advanced chemicals, empowering scientists and researchers to drive progress in science and industry.

### Contact

Address: 3281 E Guasti Rd  
Ontario, CA 91761, United States  
Phone: (601) 213-4426  
Email: [info@benchchem.com](mailto:info@benchchem.com)

Contact our Ph.D. Support Team for a compatibility check