

Technical Support Center: Modifying Protocol J-1048 for Diverse Cell Lines

Author: BenchChem Technical Support Team. **Date:** April 2026

Compound of Interest

Compound Name: J-1048
Cat. No.: B12396714

[Get Quote](#)

This technical support center provides guidance for researchers and drug development professionals on adapting the hypothetical "**J-1048**" protocol for use with various cell lines. The following troubleshooting guides and frequently asked questions (FAQs) address common issues encountered during experimental adaptation.

Frequently Asked Questions (FAQs)

Q1: What is the first step in adapting Protocol **J-1048** for a new cell line?

A1: The initial and most critical step is to establish a baseline sensitivity of the new cell line to the treatment outlined in Protocol **J-1048**. Different cell lines exhibit varied responses to chemical compounds due to their unique genetic backgrounds and protein expression profiles. We recommend performing a dose-response assay to determine the half-maximal inhibitory concentration (IC50) or half-maximal effective concentration (EC50). This will provide a quantitative measure of the cell line's sensitivity and guide the selection of appropriate concentrations for subsequent experiments.

Q2: How do I optimize the seeding density for my specific cell line when using Protocol **J-1048**?

A2: Cell seeding density is a critical parameter that can significantly impact experimental outcomes. A suboptimal density can lead to issues with cell health, proliferation rates, and response to treatment. To optimize, perform a growth curve analysis for your cell line in the specific plate format (e.g., 96-well, 24-well) used in Protocol **J-1048**. Seed cells at a range of densities and measure their proliferation over several days. The optimal seeding density should ensure that the cells are in the exponential growth phase at the time of treatment and do not become over-confluent by the end of the experiment.

Q3: Protocol **J-1048** specifies a 24-hour incubation time. Should I adjust this for my cell line?

A3: Yes, incubation time may need to be optimized. The 24-hour time point in the protocol is a general guideline. The optimal duration of treatment can vary depending on the cell line's doubling time and the mechanism of action of the compound. For rapidly proliferating cell lines, a shorter incubation time may be sufficient, while slower-growing lines might require a longer exposure to observe a significant effect. A time-course experiment, where you assess the cellular response at multiple time points (e.g., 12, 24, 48, 72 hours), is recommended to determine the ideal incubation period.

Q4: I am not observing the expected downstream signaling effects described in Protocol **J-1048**. What could be the issue?

A4: This could be due to several factors. First, confirm that the target signaling pathway of "**J-1048**" is active and relevant in your chosen cell line. You can do this by reviewing literature or performing baseline protein expression analysis (e.g., Western blotting) for key components of the pathway. Second, the kinetics of the signaling response may differ. Perform a time-course experiment and collect samples at various time points post-treatment to identify the peak response time. Finally, ensure that the concentration of the compound used is appropriate for your cell line, as determined by your initial dose-response assays.

Troubleshooting Guide

Issue	Possible Cause	Recommended Solution
High variability between replicate wells.	Inconsistent cell seeding, edge effects in the plate, or technical error during reagent addition.	Ensure thorough cell suspension mixing before seeding. Avoid using the outer wells of the plate if edge effects are suspected. Use a multichannel pipette for reagent addition to minimize timing differences.
No significant difference between control and treated groups.	The cell line is resistant to the compound at the tested concentrations. The incubation time is too short. The compound has degraded.	Perform a wider dose-response curve to test higher concentrations. Conduct a time-course experiment to assess longer incubation periods. Ensure proper storage and handling of the compound.
Excessive cell death in the vehicle control group.	High concentration of the solvent (e.g., DMSO), contamination, or suboptimal cell culture conditions.	Ensure the final concentration of the solvent in the media is non-toxic to the cells (typically <0.1% for DMSO). Regularly test for mycoplasma contamination. Optimize cell culture conditions such as media formulation, serum percentage, and incubator CO ₂ and humidity levels.
Inconsistent results between experiments.	Variation in cell passage number, reagent quality, or subtle changes in experimental conditions.	Use cells within a consistent and low passage number range. Use fresh reagents and prepare master mixes to reduce pipetting variability. Maintain detailed records of all experimental parameters.

Experimental Protocols

Protocol 1: Dose-Response Assay for IC50/EC50

Determination

- **Cell Seeding:** Seed the desired cell line in a 96-well plate at the predetermined optimal density. Allow cells to adhere and enter the exponential growth phase (typically 18-24 hours).
- **Compound Dilution:** Prepare a serial dilution of the "**J-1048**" compound in the appropriate cell culture medium. A common starting point is a 10-point, 2-fold dilution series. Include a vehicle-only control.
- **Treatment:** Carefully remove the old medium from the cells and add the medium containing the different concentrations of the compound.
- **Incubation:** Incubate the plate for the desired time (e.g., 24, 48, or 72 hours) under standard cell culture conditions (37°C, 5% CO₂).
- **Viability Assay:** Assess cell viability using a suitable method, such as an MTT, MTS, or a luminescent-based assay (e.g., CellTiter-Glo®).
- **Data Analysis:** Normalize the data to the vehicle control. Plot the normalized response against the log of the compound concentration and fit a sigmoidal dose-response curve to calculate the IC₅₀/EC₅₀ value.

Protocol 2: Optimizing Cell Seeding Density

- **Cell Preparation:** Prepare a single-cell suspension of the cell line of interest.
- **Seeding:** In a 96-well plate, seed the cells in triplicate at a range of densities (e.g., from 1,000 to 20,000 cells per well).
- **Incubation and Monitoring:** Incubate the plate under standard conditions. At 24-hour intervals for 4-5 days, measure cell proliferation in a set of triplicate wells using a viability assay.
- **Growth Curve Generation:** Plot the viability measurement against time for each seeding density.

- **Optimal Density Selection:** Choose a seeding density that allows for exponential growth throughout the intended duration of your experiment as outlined in Protocol **J-1048**, ensuring cells do not reach confluency before the experimental endpoint.

Quantitative Data Summary

The following tables provide hypothetical data for adapting Protocol **J-1048** to three different cancer cell lines: a small cell lung cancer line (NCI-H1048), a breast cancer line (MCF-7), and a colon cancer line (HT-29).

Table 1: IC50 Values for "J-1048" in Different Cell Lines

Cell Line	Tissue of Origin	IC50 (μM) after 48h
NCI-H1048	Small Cell Lung Cancer	0.5
MCF-7	Breast Cancer	2.1
HT-29	Colon Cancer	8.5

Table 2: Recommended Seeding Densities for a 96-Well Plate

Cell Line	Doubling Time (approx.)	Recommended Seeding Density (cells/well) for a 48h Experiment
NCI-H1048	30 hours	5,000
MCF-7	24 hours	8,000
HT-29	20 hours	10,000

Visualizations

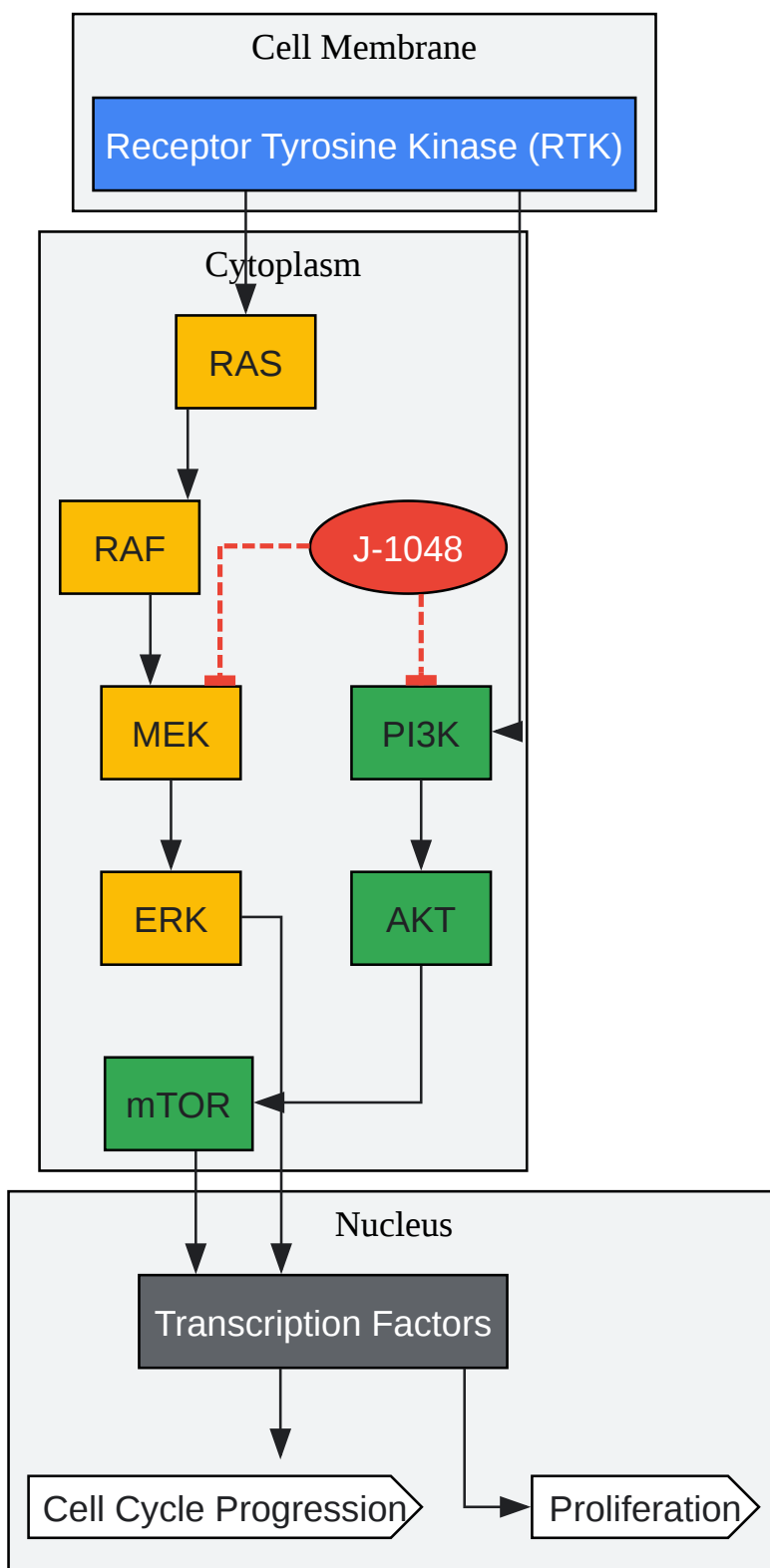

[Click to download full resolution via product page](#)

Caption: Hypothetical signaling pathway targeted by **J-1048**.



[Click to download full resolution via product page](#)

Caption: Workflow for adapting an experimental protocol to a new cell line.

- To cite this document: BenchChem. [Technical Support Center: Modifying Protocol J-1048 for Diverse Cell Lines]. BenchChem, [2026]. [Online PDF]. Available at: [\[https://www.benchchem.com/product/b12396714/docs#technical-support-center-modifying-protocol-j-1048-for-diverse-cell-lines\]](https://www.benchchem.com/product/b12396714/docs#technical-support-center-modifying-protocol-j-1048-for-diverse-cell-lines)

Disclaimer & Data Validity:

The information provided in this document is for Research Use Only (RUO) and is strictly not intended for diagnostic or therapeutic procedures. While BenchChem strives to provide accurate protocols, we make no warranties, express or implied, regarding the fitness of this product for every specific experimental setup.

Technical Support: The protocols provided are for reference purposes. Unsure if this reagent suits your experiment?

Need Industrial/Bulk Grade? [Request Custom Synthesis Quote](#)

BenchChem

Our mission is to be the trusted global source of essential and advanced chemicals, empowering scientists and researchers to drive progress in science and industry.

Contact

Address: 3281 E Guasti Rd
Ontario, CA 91761, United States
Phone: (601) 213-4426
Email: info@benchchem.com

Contact our Ph.D. Support Team for a compatibility check