

# Technical Support Center: LC-MB12 In Vivo Experiments

**Author:** BenchChem Technical Support Team. **Date:** April 2026

## Compound of Interest

Compound Name: LC-MB12  
Cat. No.: B12396849

[Get Quote](#)

This technical support center provides troubleshooting guidance and frequently asked questions for researchers utilizing **LC-MB12** in in vivo experiments. Our goal is to help you navigate common challenges and optimize your study outcomes.

## Frequently Asked Questions (FAQs)

Q1: What is **LC-MB12** and what is its primary mechanism of action?

A1: **LC-MB12** is an orally active and selective proteolysis-targeting chimera (PROTAC) designed to target Fibroblast Growth Factor Receptor 2 (FGFR2) for degradation.<sup>[1][2][3][4]</sup> It is composed of an FGFR2 inhibitor (BGJ398) linked to a ligand for the E3 ubiquitin ligase Cereblon (CRBN).<sup>[1]</sup> This dual-action molecule preferentially induces the internalization and degradation of membrane-bound FGFR2, leading to the suppression of downstream signaling pathways involved in cell division, growth, and differentiation.<sup>[2][3][4]</sup>

Q2: In which cancer models is **LC-MB12** expected to be most effective?

A2: **LC-MB12** has demonstrated significant anti-tumor effects in preclinical models of FGFR2-dependent gastric cancer.<sup>[2][3]</sup> Its efficacy is particularly pronounced in tumors with FGFR2 gene amplification or mutations.<sup>[3]</sup>

Q3: What is the recommended dosage and administration route for **LC-MB12** in mice?

A3: In published preclinical studies using SNU-16 xenograft models in nude mice, **LC-MB12** was administered orally (p.o.) at a dose of 20 mg/kg/day for 15 days.[1] This regimen resulted in a 63.1% inhibition of tumor growth.[1]

Q4: What are the known pharmacokinetic properties of **LC-MB12** in mice?

A4: **LC-MB12** exhibits rapid absorption after oral administration, with a maximum plasma concentration (C<sub>max</sub>) reached at 2.6 hours.[1] It has an oral bioavailability (F) of 13% in mice. [1]

Q5: Have any toxicity concerns been identified with **LC-MB12** in vivo?

A5: Preclinical studies have shown that **LC-MB12** is well-tolerated in mice.[1] Administration of 20 mg/kg/day for 30 days showed no apparent hepatotoxicity or nephrotoxicity.[1] However, as with any experimental compound, it is crucial to conduct independent toxicity studies within your specific animal model and experimental conditions.

## Troubleshooting Guide

Issue	Potential Cause(s)	Suggested Solution(s)
<p>Suboptimal tumor growth inhibition</p>	<p>- Insufficient Drug Exposure: The oral bioavailability of LC-MB12 is 13%[1]. Variability in gavage technique or animal-specific differences in absorption could lead to lower than expected plasma concentrations.- Tumor Model Resistance: The selected cancer cell line may not be dependent on FGFR2 signaling, or it may have developed resistance mechanisms.- Incorrect Dosing or Schedule: The dosage or frequency of administration may not be optimal for the specific tumor model.</p>	<p>- Confirm Drug Administration: Ensure proper oral gavage technique to minimize variability.- Verify FGFR2 Dependency: Confirm FGFR2 expression and signaling activation in your tumor model through techniques like Western blot or immunohistochemistry.- Dose-Response Study: Conduct a dose-response study to determine the optimal dose for your specific model.- Pharmacokinetic Analysis: Perform pharmacokinetic studies to measure plasma concentrations of LC-MB12 in your animal cohort.</p>
<p>High variability in tumor volume between animals</p>	<p>- Inconsistent Tumor Cell Implantation: Variation in the number of viable cells injected or the injection site can lead to differing tumor growth rates.- Animal Health Status: Underlying health issues in some animals can affect tumor engraftment and growth.- Inaccurate Tumor Measurement: Inconsistent caliper measurements can introduce significant variability.</p>	<p>- Standardize Cell Implantation: Ensure a consistent number of viable cells are injected into the same anatomical location for each animal.- Monitor Animal Health: Closely monitor the health and weight of all animals throughout the study.- Consistent Tumor Measurement: Have the same technician perform all tumor measurements using a standardized technique.</p>

Adverse events or toxicity observed

- Off-Target Effects: Although LC-MB12 is selective for FGFR2, high doses may lead to off-target toxicities.
- Vehicle-Related Toxicity: The formulation vehicle may be causing adverse reactions.
- Animal Model Sensitivity: The specific strain of mice being used may be more sensitive to the compound.
- Toxicity Study: Conduct a preliminary dose-escalation study to determine the maximum tolerated dose (MTD) in your specific animal model.
- Vehicle Control Group: Always include a vehicle-only control group to assess any effects of the formulation.
- Monitor Clinical Signs: Regularly monitor animals for signs of toxicity such as weight loss, lethargy, or changes in behavior.

## Quantitative Data Summary

Parameter	Value	Species	Cancer Model	Source
In Vivo Efficacy	63.1% tumor growth inhibition	Nude Mice	SNU-16 xenograft	[1]
Dosage	20 mg/kg/day, p.o.	Mice	-	[1]
Cmax	2.6 hours	Mice	-	[1]
Oral Bioavailability (F)	13%	Mice	-	[1]
In Vitro IC50 (KATO III)	29.1 nM	-	Gastric Cancer	[1]
In Vitro IC50 (SNU-16)	3.7 nM	-	Gastric Cancer	[1]
In Vitro IC50 (NCI-H716)	3.2 nM	-	-	[1]
In Vitro DC50 (KATO III)	11.8 nM	-	Gastric Cancer	[1]

## Experimental Protocols

### In Vivo Tumor Xenograft Efficacy Study

- **Cell Culture:** Culture FGFR2-dependent gastric cancer cells (e.g., SNU-16) under standard conditions.
- **Animal Model:** Utilize immunodeficient mice (e.g., nude mice).
- **Tumor Cell Implantation:** Subcutaneously inject a suspension of tumor cells (e.g.,  $5 \times 10^6$  cells in 100  $\mu$ L of PBS/Matrigel) into the flank of each mouse.
- **Tumor Growth Monitoring:** Allow tumors to reach a palpable size (e.g., 100-200 mm<sup>3</sup>). Measure tumor dimensions with calipers regularly (e.g., twice weekly) and calculate tumor volume using the formula:  $(\text{Length} \times \text{Width}^2) / 2$ .
- **Randomization:** Randomize mice into treatment and control groups.
- **Drug Preparation and Administration:** Prepare **LC-MB12** in an appropriate vehicle for oral administration. Administer the specified dose (e.g., 20 mg/kg/day) by oral gavage. The control group should receive the vehicle only.
- **Monitoring:** Monitor animal weight and health status throughout the study.
- **Endpoint:** Continue treatment for the specified duration (e.g., 15 days) or until tumors in the control group reach a predetermined endpoint.
- **Data Analysis:** At the end of the study, euthanize the animals, excise the tumors, and measure their weight. Analyze the differences in tumor volume and weight between the treatment and control groups.

## Visualizations

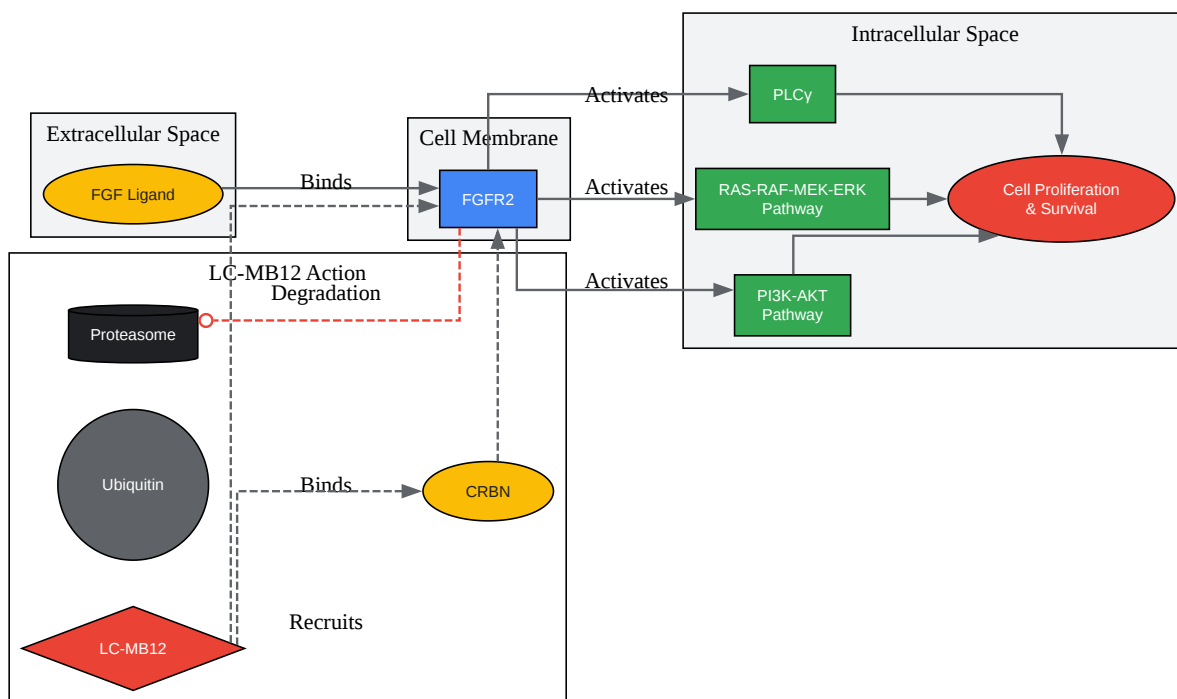

[Click to download full resolution via product page](#)

Caption: FGFR2 signaling pathway and the mechanism of **LC-MB12**-induced degradation.

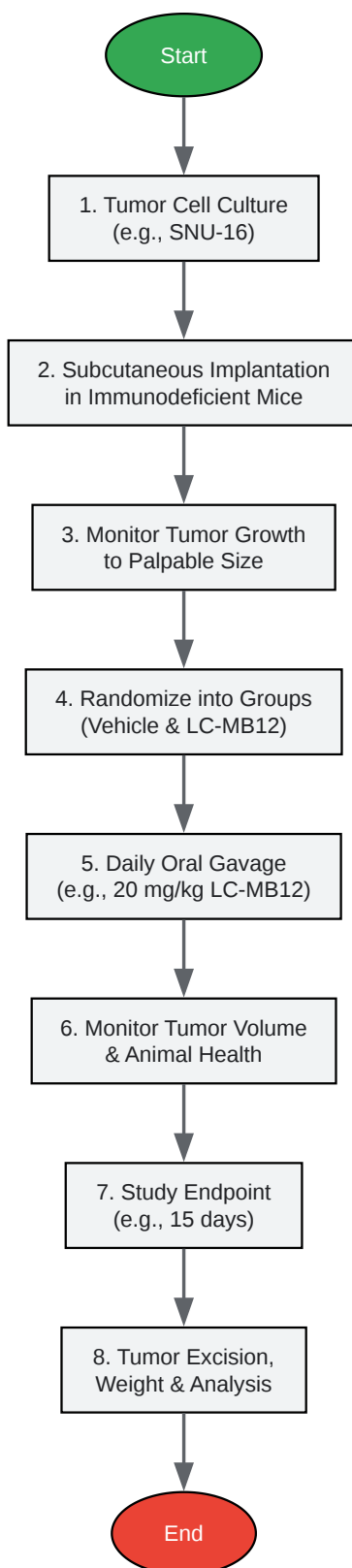

[Click to download full resolution via product page](#)

Caption: General experimental workflow for an in vivo efficacy study with **LC-MB12**.

### Need Custom Synthesis?

BenchChem offers custom synthesis for rare earth carbides and specific isotopic labeling.

Email: [info@benchchem.com](mailto:info@benchchem.com) or [Request Quote Online](#).

## References

- [1. cancer-research-network.com](https://www.cancer-research-network.com) [[cancer-research-network.com](https://www.cancer-research-network.com)]
- [2. researchgate.net](https://www.researchgate.net) [[researchgate.net](https://www.researchgate.net)]
- [3. Discovery of a Selective and Orally Bioavailable FGFR2 Degradar for Treating Gastric Cancer - PubMed](#) [[pubmed.ncbi.nlm.nih.gov](https://pubmed.ncbi.nlm.nih.gov)]
- [4. pubs.acs.org](https://pubs.acs.org) [[pubs.acs.org](https://pubs.acs.org)]
- To cite this document: BenchChem. [Technical Support Center: LC-MB12 In Vivo Experiments]. BenchChem, [2026]. [Online PDF]. Available at: [<https://www.benchchem.com/product/b12396849/docs#technical-support-center-lc-mb12-in-vivo-experiments>]

---

### Disclaimer & Data Validity:

The information provided in this document is for Research Use Only (RUO) and is strictly not intended for diagnostic or therapeutic procedures. While BenchChem strives to provide accurate protocols, we make no warranties, express or implied, regarding the fitness of this product for every specific experimental setup.

**Technical Support:** The protocols provided are for reference purposes. Unsure if this reagent suits your experiment?

**Need Industrial/Bulk Grade?** [Request Custom Synthesis Quote](#)

# BenchChem

Our mission is to be the trusted global source of essential and advanced chemicals, empowering scientists and researchers to drive progress in science and industry.

## Contact

Address: 3281 E Guasti Rd

Ontario, CA 91761, United States

Phone: (601) 213-4426

Email: [info@benchchem.com](mailto:info@benchchem.com)

[Contact our Ph.D. Support Team for a compatibility check](#)