

In Vitro Characterization of Multi-kinase-IN-3: A Technical Guide

Author: BenchChem Technical Support Team. **Date:** April 2026

Compound of Interest

Compound Name: Multi-kinase-IN-3

Cat. No.: B12396576

[Get Quote](#)

For Researchers, Scientists, and Drug Development Professionals

This technical guide provides a comprehensive overview of the in vitro characterization of **Multi-kinase-IN-3**, a novel inhibitor targeting multiple kinases implicated in oncogenic signaling pathways. This document details the biochemical and cellular activity of **Multi-kinase-IN-3**, outlines the experimental protocols for its evaluation, and visualizes key signaling pathways and workflows.

Biochemical Activity and Kinase Profiling

Multi-kinase-IN-3 was profiled against a panel of kinases to determine its potency and selectivity. The inhibitor demonstrates high affinity for key kinases involved in cell proliferation, survival, and angiogenesis.

Table 1: Kinase Inhibition Profile of **Multi-kinase-IN-3**

Kinase Target	IC50 (nM)
Primary Targets	
VEGFR2	5
PDGFR β	12
c-Kit	25
Secondary Targets	
CSF1R	50
RET	75
Off-Targets (example)	
EGFR	>10,000
HER2	>10,000

IC50 values were determined using a luminescence-based kinase assay.

Cellular Activity

The anti-proliferative effects of **Multi-kinase-IN-3** were assessed in various cancer cell lines. The compound exhibits potent inhibition of cell growth in cell lines dependent on the targeted kinases.

Table 2: Anti-proliferative Activity of **Multi-kinase-IN-3** in Cancer Cell Lines

Cell Line	Cancer Type	Key Mutations/Dependencies	GI50 (nM)
HUVEC	Endothelial	VEGFR2	15
MV-4-11	Acute Myeloid Leukemia	FLT3-ITD (c-Kit surrogate)	45
K562	Chronic Myeloid Leukemia	BCR-ABL	>5,000

GI50 values were determined using a 72-hour cell viability assay.

Experimental Protocols

Biochemical Kinase Inhibition Assay (Luminescence-based)

This assay measures the amount of ATP remaining in solution following a kinase reaction. A decrease in luminescence indicates higher kinase activity and weaker inhibition.

Protocol:

- Prepare Kinase Reaction Buffer: A buffer containing the kinase, its specific substrate, and ATP is prepared.
- Compound Dilution: **Multi-kinase-IN-3** is serially diluted to create a concentration gradient.
- Incubation: The kinase reaction is initiated by adding the kinase to the buffer containing the substrate, ATP, and varying concentrations of **Multi-kinase-IN-3**. The reaction is incubated at room temperature for 1 hour.
- Detection: A kinase detection reagent is added, which stops the kinase reaction and measures the remaining ATP via a luciferase-luciferin reaction, generating a luminescent signal.

- **Data Analysis:** The luminescent signal is read on a plate reader. IC50 values are calculated by fitting the dose-response data to a four-parameter logistic curve.

Cellular Proliferation Assay (CellTiter-Glo®)

This assay determines the number of viable cells in culture based on quantitation of the ATP present, which signals the presence of metabolically active cells.

Protocol:

- **Cell Seeding:** Cancer cell lines are seeded in 96-well plates at a predetermined density and allowed to adhere overnight.
- **Compound Treatment:** Cells are treated with a serial dilution of **Multi-kinase-IN-3** and incubated for 72 hours.
- **Lysis and Signal Generation:** CellTiter-Glo® reagent is added to each well, which lyses the cells and generates a luminescent signal proportional to the amount of ATP present.
- **Data Acquisition:** The plate is incubated for 10 minutes to stabilize the signal, and luminescence is measured using a plate reader.
- **Data Analysis:** GI50 values are determined by plotting the percentage of cell growth inhibition against the compound concentration and fitting the data to a non-linear regression curve.

Western Blot for Target Engagement

This technique is used to detect the phosphorylation status of target kinases in cells treated with **Multi-kinase-IN-3**, providing evidence of target engagement.

Protocol:

- **Cell Treatment and Lysis:** Cells are treated with various concentrations of **Multi-kinase-IN-3** for a specified time, then lysed to extract total protein.
- **Protein Quantification:** The total protein concentration in each lysate is determined using a BCA assay.

- **SDS-PAGE and Transfer:** Equal amounts of protein are separated by size via sodium dodecyl sulfate-polyacrylamide gel electrophoresis (SDS-PAGE) and then transferred to a polyvinylidene difluoride (PVDF) membrane.
- **Immunoblotting:** The membrane is blocked and then incubated with primary antibodies specific for the phosphorylated and total forms of the target kinases (e.g., p-VEGFR2, total VEGFR2).
- **Detection:** The membrane is incubated with a horseradish peroxidase (HRP)-conjugated secondary antibody, and the signal is detected using an enhanced chemiluminescence (ECL) substrate.
- **Analysis:** The band intensities are quantified to determine the ratio of phosphorylated to total protein, indicating the extent of kinase inhibition.

Signaling Pathways and Workflows

Simplified Angiogenesis and Proliferation Signaling Pathway

The following diagram illustrates the key signaling nodes targeted by **Multi-kinase-IN-3** in the context of angiogenesis and cell proliferation.

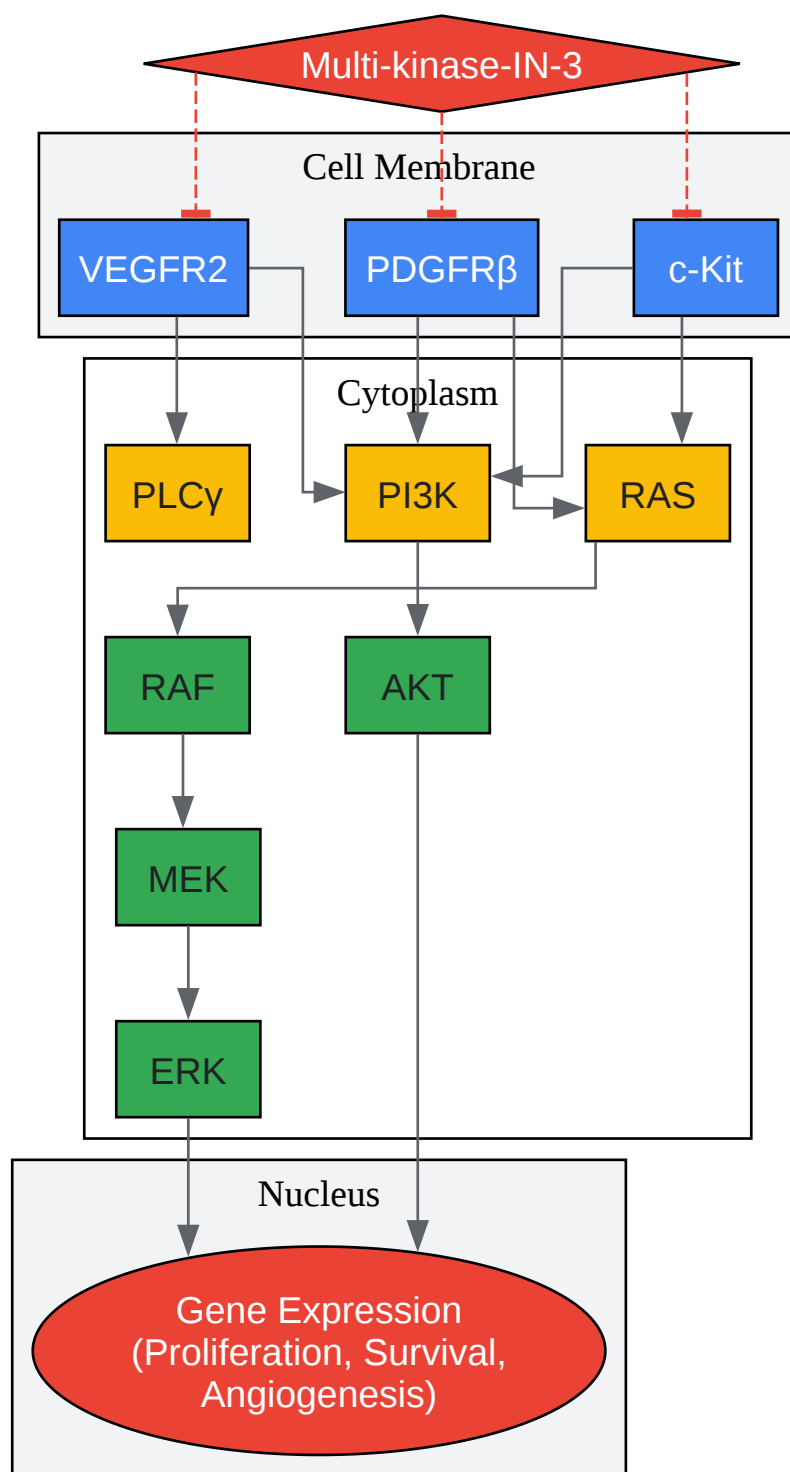

[Click to download full resolution via product page](#)

Caption: Inhibition of key receptor tyrosine kinases by **Multi-kinase-IN-3**.

Experimental Workflow for In Vitro Characterization

The following diagram outlines the typical workflow for the in vitro characterization of a multi-kinase inhibitor.

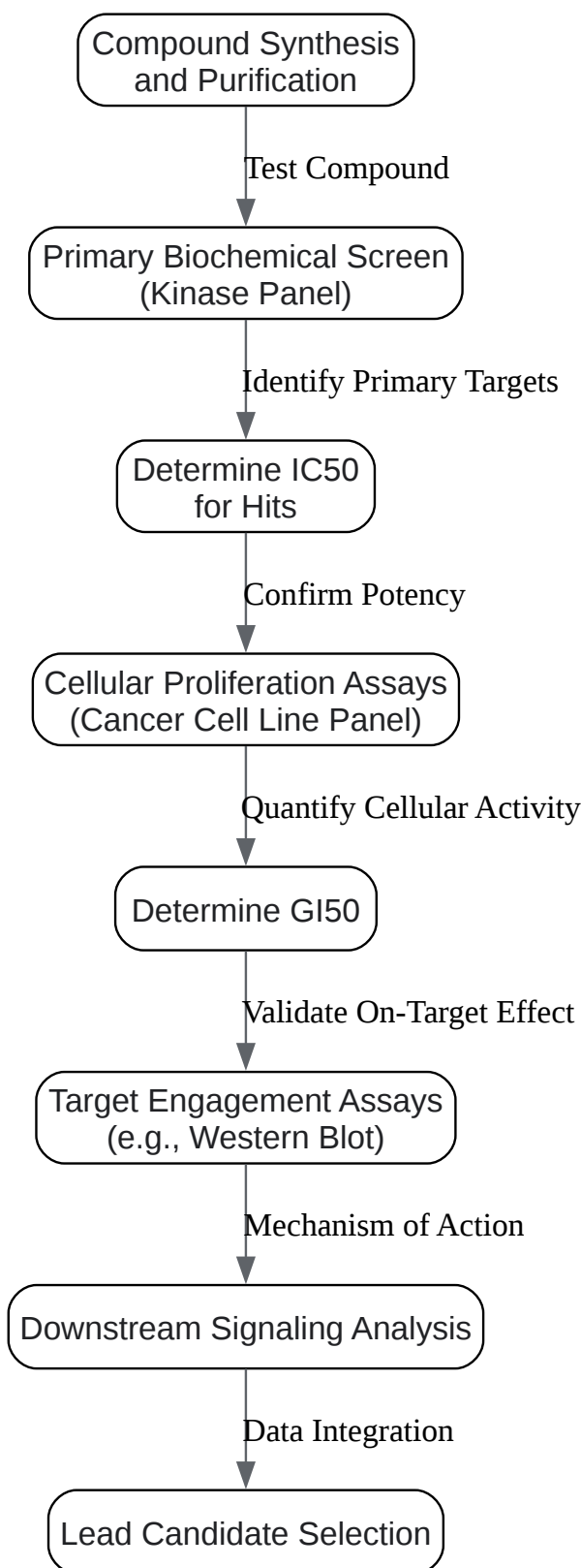

[Click to download full resolution via product page](#)

Caption: Workflow for in vitro characterization of **Multi-kinase-IN-3**.

- To cite this document: BenchChem. [In Vitro Characterization of Multi-kinase-IN-3: A Technical Guide]. BenchChem, [2026]. [Online PDF]. Available at: [<https://www.benchchem.com/product/b12396576/docs#in-vitro-characterization-of-multi-kinase-in-3-a-technical-guide>]

Disclaimer & Data Validity:

The information provided in this document is for Research Use Only (RUO) and is strictly not intended for diagnostic or therapeutic procedures. While BenchChem strives to provide accurate protocols, we make no warranties, express or implied, regarding the fitness of this product for every specific experimental setup.

Technical Support: The protocols provided are for reference purposes. Unsure if this reagent suits your experiment?

Need Industrial/Bulk Grade? [Request Custom Synthesis Quote](#)

BenchChem

Our mission is to be the trusted global source of essential and advanced chemicals, empowering scientists and researchers to drive progress in science and industry.

Contact

Address: 3281 E Guasti Rd
Ontario, CA 91761, United States
Phone: (601) 213-4426
Email: info@benchchem.com

[Contact our Ph.D. Support Team for a compatibility check](#)

