

# ALC-0315 structure and function in lipid nanoparticles

**Author:** BenchChem Technical Support Team. **Date:** May 2026

## Compound of Interest

Compound Name: 6-((4-Hydroxybutyl)amino)hexyl 2-hexyldecanoate

Cat. No.: B12396615

[Get Quote](#)

An In-Depth Technical Guide to ALC-0315: Structure and Function in Lipid Nanoparticles

## Introduction: The Linchpin of mRNA Delivery

The rapid development and deployment of mRNA vaccines against SARS-CoV-2 marked a watershed moment in pharmaceutical science, fundamentally enabled by advances in drug delivery technology. At the heart of this success are lipid nanoparticles (LNPs), sophisticated vehicles designed to protect and transport fragile mRNA molecules to their target cells. Within the intricate four-part lipid composition of these LNPs, the ionizable cationic lipid stands out as the most critical component. ALC-0315, systematically named [(4-hydroxybutyl)azanediyl]bis(hexane-6,1-diyl)bis(2-hexyldecanoate), is the ionizable lipid that became a cornerstone of the Pfizer-BioNTech BNT162b2 vaccine.<sup>[1][2][3][4]</sup>

This guide serves as a technical deep-dive into the molecular structure of ALC-0315 and the nuanced mechanisms by which it governs the efficacy of LNP-based therapeutics. As a senior application scientist, my objective is to move beyond mere description to explain the causal links between ALC-0315's chemical properties and its biological function, providing researchers and drug development professionals with a field-proven understanding of this pivotal excipient.

## Part 1: The Molecular Architecture of ALC-0315

ALC-0315 is a synthetic amino lipid characterized by a unique structure meticulously designed for nucleic acid delivery.<sup>[5][6]</sup> Its architecture consists of three key domains:

- **A Tertiary Amine Headgroup:** This is the functional core of the molecule. The nitrogen atom is bonded to a 4-hydroxybutyl group and two separate hexane chains. This tertiary amine is ionizable, meaning it can accept a proton (become protonated) under specific pH conditions.<sup>[5][7]</sup>
- **Ester Linkages:** The two hexane chains are connected via biodegradable ester bonds to the lipid tails.<sup>[5][7]</sup> These linkages are susceptible to hydrolysis within the cell, contributing to the metabolism and clearance of the lipid after it has performed its function.<sup>[5]</sup>
- **Two Branched Hydrophobic Tails:** Each arm terminates in a 2-hexyldecanoate tail. These long, branched aliphatic chains provide the necessary lipophilicity for the molecule to integrate into the lipid nanoparticle structure.<sup>[2]</sup>

The precise arrangement of these domains is not accidental; it is the result of extensive research aimed at optimizing the balance between mRNA encapsulation, particle stability, and, most importantly, endosomal escape.

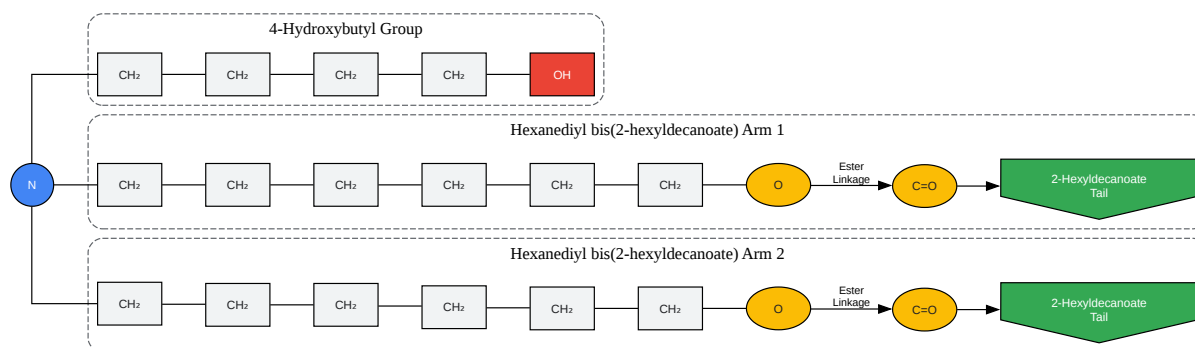



[Click to download full resolution via product page](#)

Caption: Mechanism of LNP uptake and ALC-0315-mediated endosomal escape.

## Part 4: Experimental Protocol - LNP Formulation via Microfluidics

Reproducible and scalable LNP formulation is paramount. Microfluidic mixing has become the gold standard, offering precise control over particle size and polydispersity. This self-validating system ensures that the rapid mixing of lipids in an organic phase with the mRNA in an aqueous phase leads to consistent nanoparticle self-assembly.

**Objective:** To formulate mRNA-loaded LNPs containing ALC-0315 using a microfluidic mixing device.

**Methodology:**

- **Lipid Stock Preparation (Organic Phase):** a. In a sterile glass vial, dissolve ALC-0315, DSPC, Cholesterol, and ALC-0159 in absolute ethanol to achieve the desired molar ratios (e.g., 46.3:9.4:42.7:1.6). [8][9] b. The total lipid concentration should be determined based on the specific microfluidic system and desired final concentration (e.g., 10 mg/mL total lipid). c. Gently warm the solution (e.g., to 37°C) and vortex thoroughly to ensure all components, especially cholesterol, are fully dissolved into a clear solution. [8]
- **mRNA Solution Preparation (Aqueous Phase):** a. Dilute the mRNA transcript in an acidic aqueous buffer (e.g., 100 mM sodium acetate, pH 5.0) to the target concentration. [9] b. The concentration should be calculated to achieve the desired RNA-to-lipid weight ratio (e.g., 0.05 wt/wt). [8]
- **Microfluidic Mixing:** a. Set up the microfluidic mixing system (e.g., NanoAssemblr Ignite) according to the manufacturer's instructions. [10] b. Load the lipid-ethanol solution into one syringe and the mRNA-aqueous buffer solution into another. c. Set the flow rate ratio (FRR) of the aqueous phase to the organic phase. An FRR of 3:1 is commonly used. [10] d. Set the total flow rate (TFR), which influences particle size (e.g., 10 mL/min). [10] e. Initiate the pumping process. The rapid, controlled mixing within the microfluidic cartridge induces the self-assembly of the lipids around the mRNA, forming LNPs.
- **Downstream Processing and Characterization:** a. The resulting LNP solution is diluted with a neutral buffer (e.g., PBS, pH 7.4). b. Perform buffer exchange and remove excess ethanol via dialysis or tangential flow filtration (TFF) against PBS (pH 7.4). [8] c. Sterile filter the final

LNP formulation through a 0.2  $\mu\text{m}$  filter. [8] d. Characterize the final product for size, polydispersity index (PDI), and zeta potential using Dynamic Light Scattering (DLS), and determine mRNA encapsulation efficiency using a fluorescent dye-based assay (e.g., RiboGreen).

## Conclusion

ALC-0315 is more than just a structural component; it is a dynamic, functional excipient that embodies the principles of intelligent drug delivery design. Its carefully tuned pKa is the linchpin of its activity, enabling it to remain inert in circulation, actively capture its mRNA payload during formulation, and trigger its release into the cytoplasm at the precise subcellular location. Comparative studies have shown that ALC-0315-based LNPs can elicit higher antibody levels and stronger cellular immune responses compared to LNPs formulated with other ionizable lipids like MC3, underscoring its efficacy. [11][12] Understanding the intricate relationship between the structure of ALC-0315 and its pH-dependent function is essential for any scientist working to harness the power of lipid nanoparticles for the next generation of genetic medicines.

## References

- Title: ALC-0315: How a Breakthrough Lipid Carrier is Driving Efficient mRNA Vaccine Delivery Source: CordenPharma URL:[[Link](#)]
- Title: Ionizable Lipid Nanoparticles for mRNA Delivery: Internal Self-Assembled Inverse Mesophase Structure and Endosomal Escape Source: ACS Publications URL:[[Link](#)]
- Title: Ionizable lipids key role in novel RNA-lipid nanoparticle therapies Source: Inside Therapeutics URL:[[Link](#)]
- Title: Comprehensive characterization of the lipid nanoparticle (LNP), ALC-0315, and its impurities using electron-activated dissociation (EAD) Source: SCIEX URL:[[Link](#)]
- Title: Recent Advances in the Lipid Nanoparticle-Mediated Delivery of mRNA Vaccines Source: National Institutes of Health (NIH) URL:[[Link](#)]
- Title: ALC-0315 Source: Grokipedia URL:[[Link](#)]

- Title: A Route to Synthesize Ionizable Lipid ALC-0315, a Key Component of the mRNA Vaccine Lipid Matrix Source: National Institutes of Health (NIH) URL:[[Link](#)]
- Title: Ionizable Lipid Nanoparticles for mRNA Delivery: Internal Self-Assembled Inverse Mesophase Structure and Endosomal Escape Source: PubMed URL:[[Link](#)]
- Title: Ionizable Lipids to Optimize RNA-LNP Delivery Source: YouTube URL:[[Link](#)]
- Title: A Route to Lipid ALC-0315: a Key Component of a COVID-19 mRNA Vaccine Source: National Institutes of Health (NIH) URL:[[Link](#)]
- Title: ALC-0315 Lipid-Based mRNA LNP Induces Stronger Cellular Immune Responses Postvaccination Source: PubMed URL:[[Link](#)]
- Title: Alc-0315 | C48H95NO5 Source: PubChem - National Institutes of Health (NIH) URL: [[Link](#)]
- Title: ALC-0315 Source: Wikipedia URL:[[Link](#)]
- Title: Measuring the pKa of ALC-0315 ionisable lipid LNPs Source: ResearchGate URL:[[Link](#)]
- Title: Lipid Nanoparticle Development for A Fluvid mRNA Vaccine Targeting Seasonal Influenza and SARS-CoV-2 Source: National Institutes of Health (NIH) URL:[[Link](#)]
- Title: Quantification and impurity analysis of ALC-0315 from LNPs in plasma using the ZenoTOF 7600 system Source: SCIEX URL:[[Link](#)]
- Title: Endosomal escape mechanisms of extracellular vesicle-based drug carriers: lessons for lipid nanoparticle design Source: National Institutes of Health (NIH) URL:[[Link](#)]
- Title: Routes of synthesis of the ALC-0315 lipid. Source: ResearchGate URL:[[Link](#)]
- Title: Quantification and impurity analysis of ALC-0315 from LNPs in plasma using the ZenoTOF 7600 system Source: ResearchGate URL:[[Link](#)]
- Title: Endosomal Escape of Lipid Nanoparticles: A New Perspective on the Literature Data Source: MDPI URL:[[Link](#)]

- Title: Decoding pH-Driven Phase Transition of Lipid Nanoparticles Source: bioRxiv URL: [\[Link\]](#)
- Title: ALC-0315 Lipid-Based mRNA LNP Induces Stronger Cellular Immune Responses Postvaccination Source: ResearchGate URL:[\[Link\]](#)
- Title: Continuous flow synthesis of the ionizable lipid ALC-0315 Source: ResearchGate URL: [\[Link\]](#)
- Title: Endo/Lysosomal-Escapable Lipid Nanoparticle Platforms for Enhancing mRNA Delivery in Cancer Therapy Source: PubMed Central - National Institutes of Health (NIH) URL:[\[Link\]](#)
- Title: Wrap, Pack, Release: Phase Transition of mRNA Lipid Nanoparticles Under the Computational Microscope Source: Biophysical Society URL:[\[Link\]](#)
- Title: pH-dependent structural transitions in cationic ionizable lipid mesophases are critical for lipid nanoparticle function Source: ResearchGate URL:[\[Link\]](#)
- Title: Endosomal Escape of Lipid Nanoparticles: A Perspective on the Literature Data Source: MDPI URL:[\[Link\]](#)
- Title: Endosomal Escape: A Critical Challenge in LNP-Mediated Therapeutics Source: Inside Therapeutics URL:[\[Link\]](#)

### Need Custom Synthesis?

BenchChem offers custom synthesis for rare earth carbides and specific isotopic labeling.

Email: [info@benchchem.com](mailto:info@benchchem.com) or [Request Quote Online](#).

## Sources

- [1. grokipedia.com](https://grokipedia.com) [[grokipedia.com](https://grokipedia.com)]
- [2. A Route to Synthesize Ionizable Lipid ALC-0315, a Key Component of the mRNA Vaccine Lipid Matrix - PMC](https://pubmed.ncbi.nlm.nih.gov/) [[pmc.ncbi.nlm.nih.gov](https://pubmed.ncbi.nlm.nih.gov/)]
- [3. ALC-0315 - Wikipedia](https://en.wikipedia.org/) [[en.wikipedia.org](https://en.wikipedia.org/)]
- [4. ALC-0315: Application and Synthesis\\_Chemicalbook](https://chemicalbook.com/) [[chemicalbook.com](https://chemicalbook.com/)]

- [5. What is ALC-0315? | BroadPharm \[broadpharm.com\]](#)
- [6. ALC-0315, 2036272-55-4 | BroadPharm \[broadpharm.com\]](#)
- [7. Ionizable Lipid Nanoparticles for mRNA Delivery: Internal Self-Assembled Inverse Mesophase Structure and Endosomal Escape - PubMed \[pubmed.ncbi.nlm.nih.gov\]](#)
- [8. medchemexpress.com \[medchemexpress.com\]](#)
- [9. file.medchemexpress.com \[file.medchemexpress.com\]](#)
- [10. sciex.com \[sciex.com\]](#)
- [11. ALC-0315: How a Breakthrough Lipid Carrier is Driving Efficient mRNA Vaccine Delivery | MolecularCloud \[molecularcloud.org\]](#)
- [12. ALC-0315 Lipid-Based mRNA LNP Induces Stronger Cellular Immune Responses Postvaccination - PubMed \[pubmed.ncbi.nlm.nih.gov\]](#)
- [To cite this document: BenchChem. \[ALC-0315 structure and function in lipid nanoparticles\]. BenchChem, \[2026\]. \[Online PDF\]. Available at: \[https://www.benchchem.com/product/b12396615/docs#alc-0315-structure-and-function-in-lipid-nanoparticles\]](#)

---

#### Disclaimer & Data Validity:

The information provided in this document is for Research Use Only (RUO) and is strictly not intended for diagnostic or therapeutic procedures. While BenchChem strives to provide accurate protocols, we make no warranties, express or implied, regarding the fitness of this product for every specific experimental setup.

**Technical Support:** The protocols provided are for reference purposes. Unsure if this reagent suits your experiment?

**Need Industrial/Bulk Grade?** [Request Custom Synthesis Quote](#)

# BenchChem

Our mission is to be the trusted global source of essential and advanced chemicals, empowering scientists and researchers to drive progress in science and industry.

## Contact

Address: 3281 E Guasti Rd

Ontario, CA 91761, United States

Phone: (601) 213-4426

Email: [info@benchchem.com](mailto:info@benchchem.com)

[Contact our Ph.D. Support Team for a compatibility check](#)