

Technical Support Center: Optimizing STING Agonist-25 Dosage and Scheduling

Author: BenchChem Technical Support Team. **Date:** April 2026

Compound of Interest

Compound Name: STING agonist-25

Cat. No.: B12395476

[Get Quote](#)

Welcome to the Technical Support Center for **STING Agonist-25**. This resource is intended for researchers, scientists, and drug development professionals to provide guidance on the effective use of **STING Agonist-25** in your experiments. Here, you will find troubleshooting guides, frequently asked questions (FAQs), detailed experimental protocols, and comparative data to facilitate the optimization of dosage and scheduling for maximal therapeutic benefit.

Frequently Asked Questions (FAQs)

Q1: What is the general mechanism of action for **STING Agonist-25**?

A1: **STING Agonist-25** is a non-nucleotide, small-molecule agonist of the Stimulator of Interferon Genes (STING) pathway. Upon binding to the STING protein, which is located on the endoplasmic reticulum, it induces a conformational change that leads to the recruitment and activation of TANK-binding kinase 1 (TBK1). TBK1 then phosphorylates Interferon Regulatory Factor 3 (IRF3), which dimerizes and translocates to the nucleus. In the nucleus, p-IRF3 acts as a transcription factor, driving the expression of type I interferons (such as IFN- β) and other pro-inflammatory cytokines and chemokines like CXCL10.^{[1][2]} This cascade of events activates the innate immune system, leading to the maturation of dendritic cells, enhanced

antigen presentation, and the priming of tumor-specific T cells, ultimately converting an immunologically "cold" tumor microenvironment into a "hot" one.[1][3][4]

Q2: How should I determine the optimal in vitro concentration of **STING Agonist-25** for my experiments?

A2: The optimal in vitro concentration of **STING Agonist-25** should be determined empirically for each cell line and assay. It is highly recommended to perform a dose-response experiment to identify the concentration that yields maximal STING activation without inducing significant cytotoxicity. A typical starting point for non-nucleotide STING agonists can range from the low micromolar to nanomolar concentrations. Key readouts for STING activation include the phosphorylation of STING, TBK1, and IRF3 (via Western blot), and the secretion of IFN- β or CXCL10 (via ELISA or qPCR). For example, a similar non-nucleotide STING agonist, STING agonist-22 (CF501), has been shown to robustly activate innate immune responses in THP-1 cells.

Q3: What are the recommended routes of administration for **STING Agonist-25** in preclinical animal models?

A3: The route of administration can significantly impact the efficacy and systemic exposure of STING agonists. Intratumoral (i.t.) injection is a common method used in preclinical studies to maximize local concentration within the tumor microenvironment and minimize systemic toxicity. However, systemic administration (e.g., intravenous, subcutaneous, or oral) is also being explored, particularly for non-nucleotide agonists that may have more favorable pharmacokinetic properties. The choice of administration route will depend on the specific research question and the formulation of **STING Agonist-25**.

Q4: What are the potential toxicities associated with **STING Agonist-25**, and how can they be mitigated?

A4: Over-activation of the STING pathway can lead to excessive inflammation and cytokine release, potentially causing systemic toxicity. STING agonists have also been reported to be toxic to T cells at high concentrations. To mitigate these risks, it is crucial to carefully optimize the dose and schedule. Using the lowest effective dose and employing intermittent scheduling can help to manage toxicity while still achieving a therapeutic effect. Additionally, local delivery

methods like intratumoral injection can limit systemic exposure. Monitoring for signs of toxicity, such as weight loss and changes in animal behavior, is essential during in vivo studies.

Troubleshooting Guides

Issue	Potential Cause	Recommended Solution
Low or no STING activation in vitro	Low STING expression in the cell line: Not all cell lines express STING at sufficient levels.	Verify STING protein expression by Western blot or flow cytometry. Choose a cell line known to have a functional STING pathway (e.g., THP-1, B16-F10).
Inefficient cellular uptake: As a small molecule, cellular permeability may vary.	Consider using a transfection reagent or a delivery vehicle if direct application is not effective. However, many non-nucleotide agonists are designed for better cell permeability.	
Degradation of the agonist: The compound may be unstable under certain experimental conditions.	Prepare fresh solutions for each experiment and minimize freeze-thaw cycles. Follow the manufacturer's storage and handling recommendations.	
High cytotoxicity observed in vitro	Excessive STING activation: High concentrations of STING agonists can induce apoptosis.	Reduce the concentration of STING Agonist-25. Perform a dose-response curve to find the optimal balance between activation and viability.
Off-target effects: The compound may have other cellular targets at high concentrations.	Titrate the dose to the lowest effective concentration.	
Lack of in vivo anti-tumor efficacy	Suboptimal dosage or scheduling: The dose may be too low to induce a robust immune response, or the scheduling may not be optimal.	Perform a dose-escalation study to find the most effective dose. Experiment with different schedules (e.g., more frequent, or intermittent dosing). Some studies suggest

lower doses may be more effective than high doses.

Immunosuppressive tumor microenvironment: The tumor may have strong intrinsic mechanisms of immune evasion.

Combine STING Agonist-25 with other immunotherapies, such as checkpoint inhibitors (e.g., anti-PD-1).

Poor pharmacokinetics or tumor penetration: The agonist may be rapidly cleared or may not reach the tumor in sufficient concentrations when administered systemically.

Consider intratumoral administration to increase local concentration. If systemic administration is necessary, formulation with a delivery vehicle may improve pharmacokinetics.

Data on STING Agonist Dosage and Scheduling in Preclinical Models

The following tables summarize representative data from preclinical studies on various STING agonists. This information can serve as a starting point for designing experiments with **STING Agonist-25**.

Table 1: In Vitro STING Agonist Activity

Agonist	Cell Line	Assay	Effective Concentration (EC50)	Reference
diABZI	THP-1	IFN- β Secretion	3.1 \pm 0.6 μ M	
MSA-2 covalent dimer	THP-1	IFN- β Secretion	8 \pm 7 nM	
STING Agonist 12L	THP-1	Reporter Gene	0.38 μ M	
KAS-08	THP-1	Reporter Gene	0.18 μ M	

Table 2: In Vivo STING Agonist Monotherapy in Syngeneic Mouse Models

Agonist	Tumor Model	Mouse Strain	Dose and Route	Scheduling	Outcome	Reference
cGAMP	4T1 Breast Cancer	BALB/c	10 µg, intratumoral	Days 13, 17, 21	Significant tumor growth inhibition	
ADU-S100	CT26 Colon Carcinoma	BALB/c	20 µg, intratumoral	Days 10, 16	Significant reduction in tumor volume	
MSA-2	MC38 Colon Adenocarcinoma	C57BL/6	450 µg, intratumoral	Single dose	Tumor regression and long-lasting immunity	
STING Agonist 12L	B16/F10 Melanoma	C57BL/6	10 mg/kg	Not specified	Reduced tumor volume and lung metastases	

Experimental Protocols

Protocol 1: In Vitro STING Activation Assay

This protocol describes a general method for assessing the activation of the STING pathway in a human monocytic cell line (THP-1) by measuring IFN- β secretion.

Materials:

- THP-1 cells
- RPMI-1640 medium with 10% FBS

- **STING Agonist-25**

- 96-well cell culture plates
- Human IFN- β ELISA kit

Procedure:

- Cell Seeding: Seed THP-1 cells at a density of 1×10^5 cells per well in a 96-well plate and incubate for 24 hours.
- Compound Preparation: Prepare serial dilutions of **STING Agonist-25** in complete culture medium. A suggested starting range is 0.01 μ M to 50 μ M.
- Cell Treatment: Add the diluted agonist to the cells and incubate for 18-24 hours at 37°C in a 5% CO₂ incubator.
- Supernatant Collection: After incubation, centrifuge the plate and carefully collect the supernatant.
- ELISA: Measure the concentration of IFN- β in the supernatant using a human IFN- β ELISA kit according to the manufacturer's instructions.
- Data Analysis: Plot the IFN- β concentration against the agonist concentration to determine the EC₅₀ value.

Protocol 2: In Vivo Anti-Tumor Efficacy Study

This protocol provides a general framework for evaluating the anti-tumor activity of **STING Agonist-25** in a syngeneic mouse tumor model.

Materials:

- 6-8 week old BALB/c or C57BL/6 mice
- Syngeneic tumor cells (e.g., CT26, B16-F10)
- **STING Agonist-25** formulated in a suitable vehicle (e.g., saline with 5% DMSO)

- Calipers for tumor measurement
- Syringes and needles

Procedure:

- Tumor Implantation: Subcutaneously inject 5×10^5 to 1×10^6 tumor cells into the flank of each mouse.
- Tumor Growth Monitoring: Allow tumors to grow to an average volume of 50-100 mm³. Measure tumor volume every 2-3 days using calipers (Volume = $0.5 \times \text{Length} \times \text{Width}^2$).
- Randomization: Randomize mice into treatment and vehicle control groups (n=8-10 mice per group).
- Treatment Administration: Administer **STING Agonist-25** or vehicle via the desired route (e.g., intratumoral injection of 10-50 µg). A common schedule is to treat on days 7, 10, and 13 post-implantation.
- Continued Monitoring: Continue to monitor tumor growth and body weight throughout the study.
- Endpoint: Euthanize mice when tumors reach a predetermined size or at the end of the study period. Tumors and relevant tissues can be collected for further analysis (e.g., flow cytometry, immunohistochemistry).

Visualizations

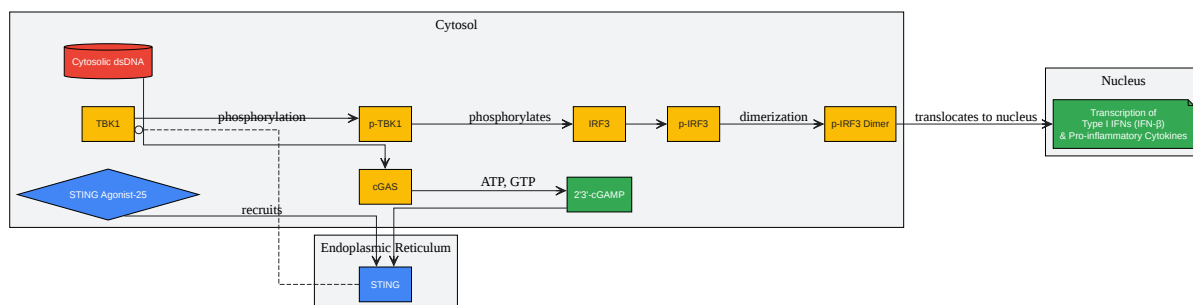

[Click to download full resolution via product page](#)

Caption: The cGAS-STING signaling pathway activated by **STING Agonist-25**.

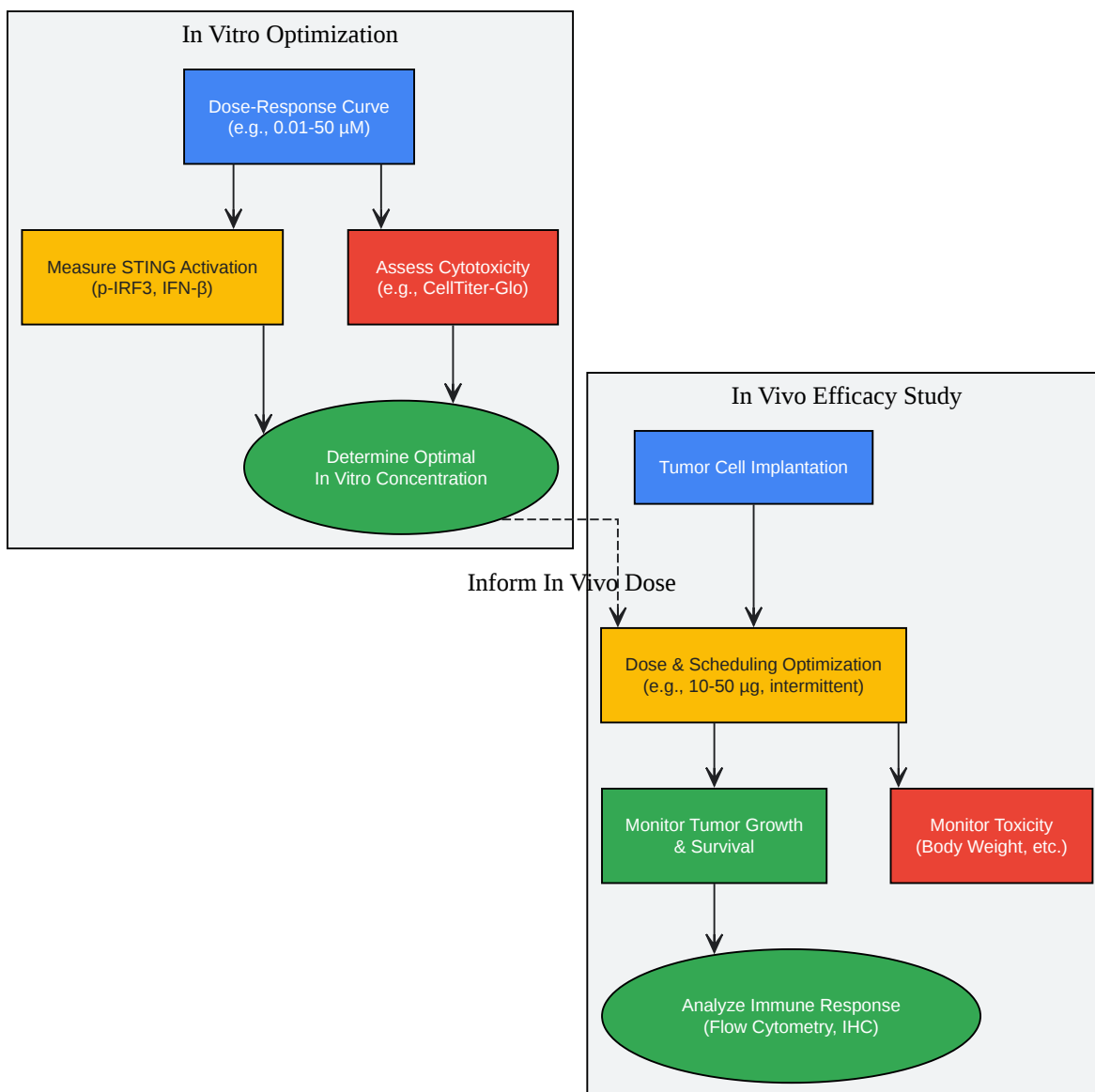

[Click to download full resolution via product page](#)

Caption: A logical workflow for optimizing **STING Agonist-25** dosage.

Need Custom Synthesis?

BenchChem offers custom synthesis for rare earth carbides and specific isotopic labeling.

Email: info@benchchem.com or [Request Quote Online](#).

References

- [1. STING Agonists and How to Reach Their Full Potential in Cancer Immunotherapy - PMC \[pmc.ncbi.nlm.nih.gov\]](#)
- [2. mdpi.com \[mdpi.com\]](#)
- [3. Trial watch: STING agonists in cancer therapy - PMC \[pmc.ncbi.nlm.nih.gov\]](#)
- [4. Frontiers | The activation of cGAS-STING pathway offers novel therapeutic opportunities in cancers \[frontiersin.org\]](#)
- To cite this document: BenchChem. [Technical Support Center: Optimizing STING Agonist-25 Dosage and Scheduling]. BenchChem, [2026]. [Online PDF]. Available at: [\[https://www.benchchem.com/product/b12395476/docs#technical-support-center-optimizing-sting-agonist-25-dosage-and-scheduling\]](https://www.benchchem.com/product/b12395476/docs#technical-support-center-optimizing-sting-agonist-25-dosage-and-scheduling)

Disclaimer & Data Validity:

The information provided in this document is for Research Use Only (RUO) and is strictly not intended for diagnostic or therapeutic procedures. While BenchChem strives to provide accurate protocols, we make no warranties, express or implied, regarding the fitness of this product for every specific experimental setup.

Technical Support: The protocols provided are for reference purposes. Unsure if this reagent suits your experiment?

Need Industrial/Bulk Grade? [Request Custom Synthesis Quote](#)

BenchChem

Our mission is to be the trusted global source of essential and advanced chemicals, empowering scientists and researchers to drive progress in science and industry.

Contact

Address: 3281 E Guasti Rd

Ontario, CA 91761, United States

Phone: (601) 213-4426

Email: info@benchchem.com

[Contact our Ph.D. Support Team for a compatibility check](#)