

Application Notes and Protocols for hCAXII-IN-3 in Molecular Docking Studies

Author: BenchChem Technical Support Team. **Date:** December 2025

Compound of Interest

Compound Name: hCAXII-IN-3

Cat. No.: B12395617

[Get Quote](#)

For Researchers, Scientists, and Drug Development Professionals

These application notes provide a comprehensive guide to utilizing **hCAXII-IN-3**, a potent human carbonic anhydrase (hCA) inhibitor, in molecular docking studies. This document outlines the inhibitor's known biochemical data, a detailed protocol for in silico analysis of its interaction with human carbonic anhydrase XII (hCA XII), and the broader context of hCA XII's role in physiological and pathological processes.

Introduction to hCAXII-IN-3

hCAXII-IN-3 (also known as Compound 16) is a human carbonic anhydrase inhibitor with nanomolar potency against several isoforms.[1] Of particular interest is its strong inhibition of the transmembrane, tumor-associated isoform hCA XII.[1] hCA XII is overexpressed in various cancers and contributes to the acidification of the tumor microenvironment, promoting tumor growth, invasion, and resistance to therapy.[2][3] Molecular docking is a crucial computational technique used to predict the binding mode and affinity of inhibitors like **hCAXII-IN-3** to their protein targets, thereby guiding the design of more potent and selective anticancer agents.[2][4][5]

Quantitative Data for hCAXII-IN-3

The inhibitory activity of **hCAXII-IN-3** has been evaluated against four key human carbonic anhydrase isoforms. The data clearly indicates potent inhibition of isoforms II, IX, and XII, with weaker activity against isoform I.

Isoform	Ki (nM)
hCA I	403.8
hCA II	5.1
hCA IX	10.2
hCA XII	5.2

Table 1: Inhibitory Potency (Ki) of hCAXII-IN-3 against various human Carbonic Anhydrase isoforms.[1]

Mechanism of Action and Inhibition of hCA XII

Human carbonic anhydrases are zinc-metalloenzymes that catalyze the reversible hydration of carbon dioxide to bicarbonate and a proton.[3][6][7] This reaction is fundamental to pH regulation.[3][8] The catalytic mechanism involves a zinc-bound hydroxide ion that acts as a nucleophile.[9] Inhibitors like **hCAXII-IN-3** typically function by coordinating to the catalytic zinc ion (Zn^{2+}) in the active site, displacing the zinc-bound water/hydroxide and preventing the binding of the CO_2 substrate.[6] The sulfonamide group, a common feature in many CA inhibitors, is a classic zinc-binding group.[6][10]

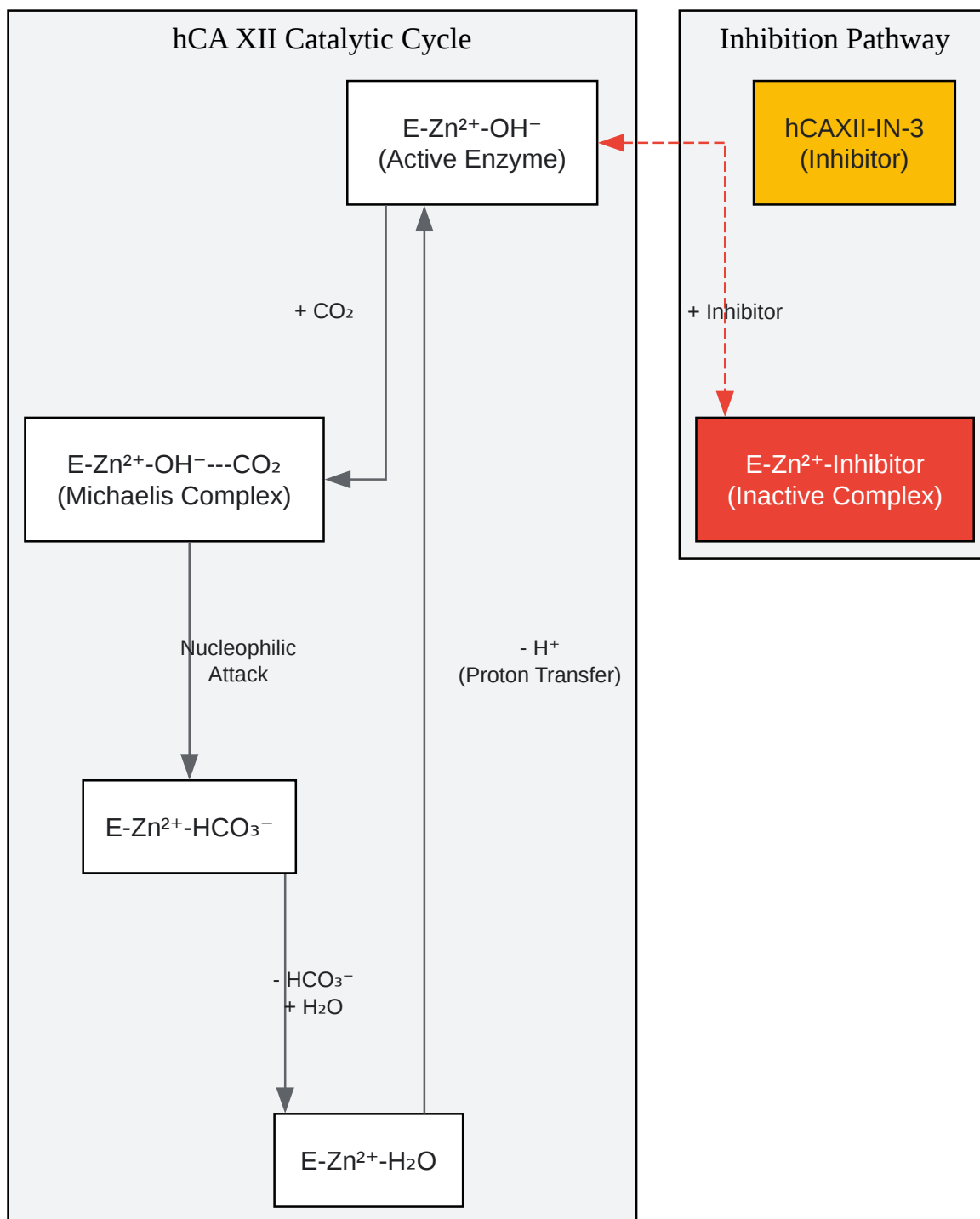

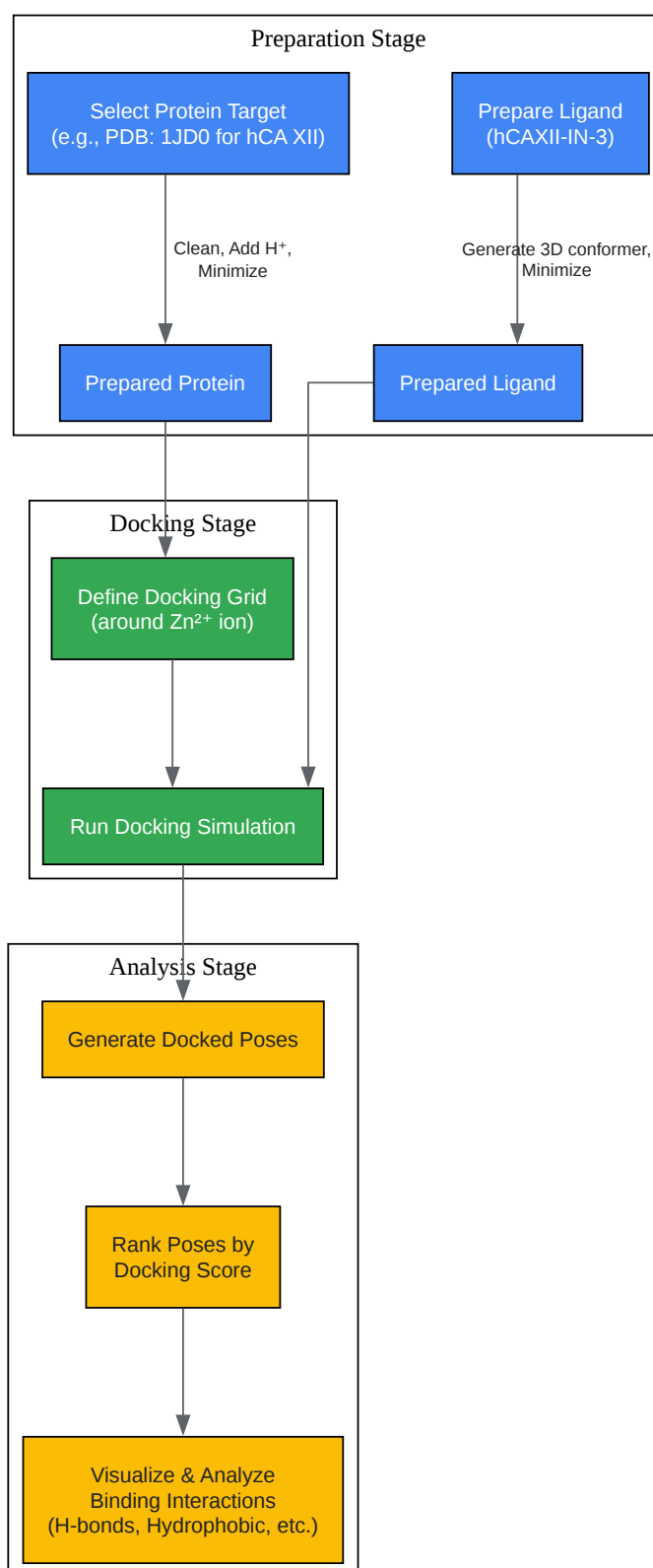

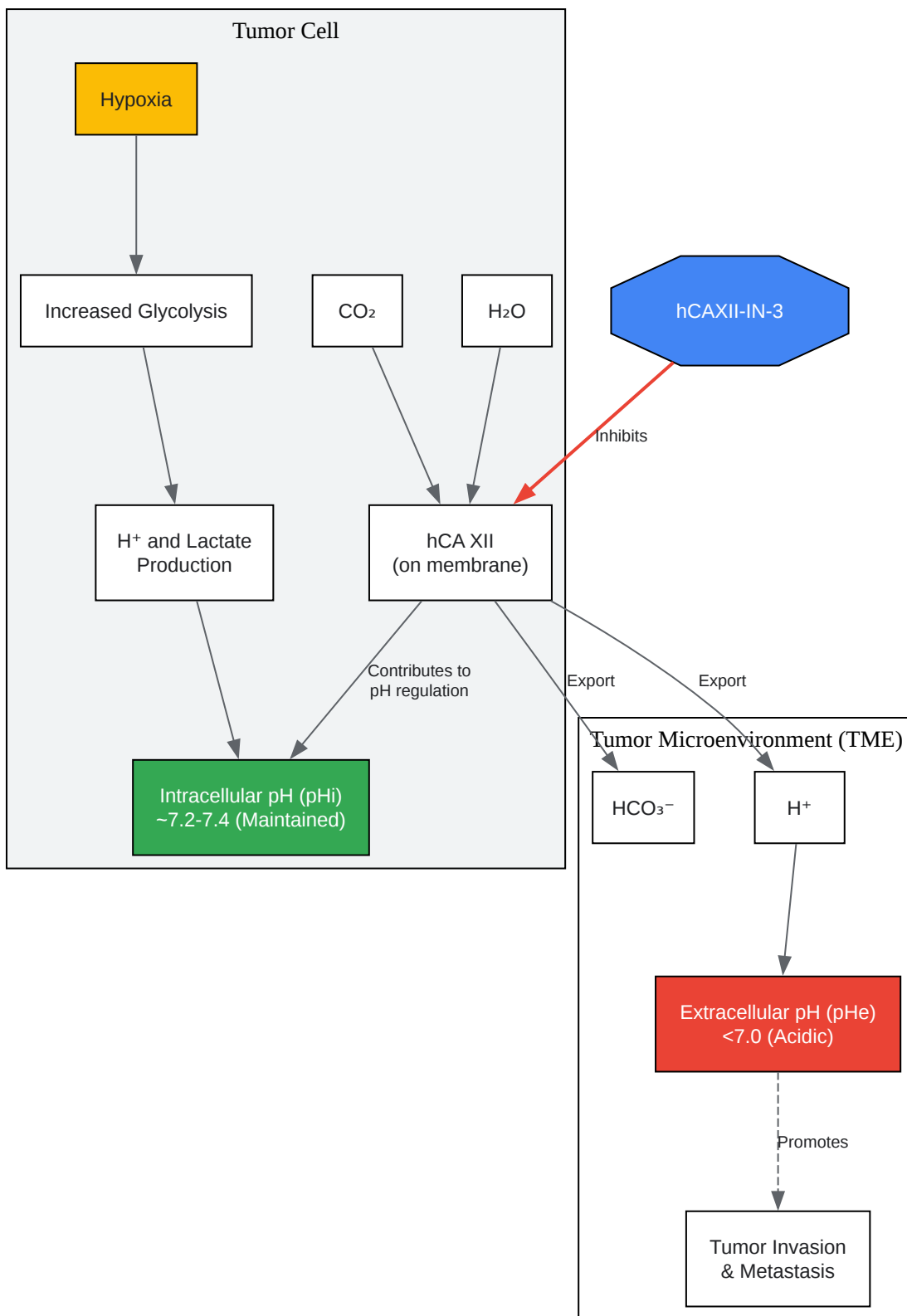

[Click to download full resolution via product page](#)

Need Custom Synthesis?

BenchChem offers custom synthesis for rare earth carbides and specific isotopic labeling.

Email: info@benchchem.com or [Request Quote Online](#).

References

- 1. medchemexpress.com [medchemexpress.com]
- 2. Screening Campaign and Docking Investigations in Identifying New Hit Compounds as Inhibitors of Human Carbonic Anhydrases Expressed In Tumour Cells - PubMed [pubmed.ncbi.nlm.nih.gov]
- 3. The three-tails approach as a new strategy to improve selectivity of action of sulphonamide inhibitors against tumour-associated carbonic anhydrase IX and XII - PMC [pmc.ncbi.nlm.nih.gov]
- 4. researchgate.net [researchgate.net]
- 5. researchgate.net [researchgate.net]
- 6. Synthesis, Carbonic Anhydrase II/IX/XII Inhibition, DFT, and Molecular Docking Studies of Hydrazide-Sulfonamide Hybrids of 4-Methylsalicyl- and Acyl-Substituted Hydrazide - PMC [pmc.ncbi.nlm.nih.gov]
- 7. Design, synthesis, and biological investigation of selective human carbonic anhydrase II, IX, and XII inhibitors using 7-aryl/heteroaryl triazolopyrimidines bearing a sulfanilamide scaffold - PMC [pmc.ncbi.nlm.nih.gov]
- 8. A class of carbonic anhydrase IX/XII – selective carboxylate inhibitors - PMC [pmc.ncbi.nlm.nih.gov]
- 9. Discovery of the first-in-class potent and isoform-selective human carbonic anhydrase III inhibitors - PMC [pmc.ncbi.nlm.nih.gov]
- 10. Metalloprotein-inhibitor binding: Human carbonic anhydrase II as a model for probing metal-ligand interactions in a metalloprotein active site - PMC [pmc.ncbi.nlm.nih.gov]
- To cite this document: BenchChem. [Application Notes and Protocols for hCAXII-IN-3 in Molecular Docking Studies]. BenchChem, [2025]. [Online PDF]. Available at: [https://www.benchchem.com/product/b12395617#hcaxii-in-3-application-in-molecular-docking-studies]

Disclaimer & Data Validity:

The information provided in this document is for Research Use Only (RUO) and is strictly not intended for diagnostic or therapeutic procedures. While BenchChem strives to provide accurate protocols, we make no warranties, express or implied, regarding the fitness of this product for every specific experimental setup.

Technical Support: The protocols provided are for reference purposes. Unsure if this reagent suits your experiment? [[Contact our Ph.D. Support Team for a compatibility check](#)]

Need Industrial/Bulk Grade? [Request Custom Synthesis Quote](#)

BenchChem

Our mission is to be the trusted global source of essential and advanced chemicals, empowering scientists and researchers to drive progress in science and industry.

Contact

Address: 3281 E Guasti Rd
Ontario, CA 91761, United States
Phone: (601) 213-4426
Email: info@benchchem.com