

# Application Notes and Protocols: Labeling Oligonucleotides with Sulfo-Cy5 Azide

**Author:** BenchChem Technical Support Team. **Date:** April 2026

## Compound of Interest

Compound Name: Sulfo-Cy5 azide

Cat. No.: B12395390

[Get Quote](#)

For Researchers, Scientists, and Drug Development Professionals

## Introduction

Fluorescently labeled oligonucleotides are indispensable tools in molecular biology, diagnostics, and therapeutic development. Cyanine 5 (Cy5), a bright and photostable fluorophore that emits in the far-red spectrum, is a popular choice for labeling. This document provides detailed protocols for labeling alkyne-modified oligonucleotides with **Sulfo-Cy5 azide** via Copper-Free Click Chemistry, specifically Strain-Promoted Alkyne-Azide Cycloaddition (SPAAC). The sulfonated (Sulfo) form of Cy5 azide offers excellent water solubility, making it ideal for reactions in aqueous environments.[1]

The SPAAC reaction is a bioorthogonal ligation method that occurs efficiently under mild conditions without the need for a cytotoxic copper catalyst, which can damage DNA.[2][3][4] This makes it a superior choice for labeling sensitive biological molecules. The reaction involves the cycloaddition of a strained alkyne, such as dibenzocyclooctyne (DBCO), incorporated into an oligonucleotide, with the azide group of the Sulfo-Cy5 dye.[3][4]

## Chemical Reaction and Workflow

The core of the labeling process is the Strain-Promoted Alkyne-Azide Cycloaddition (SPAAC). This reaction is a type of 1,3-dipolar cycloaddition between a cyclooctyne and an azide, forming a stable triazole linkage.<sup>[3][5]</sup>

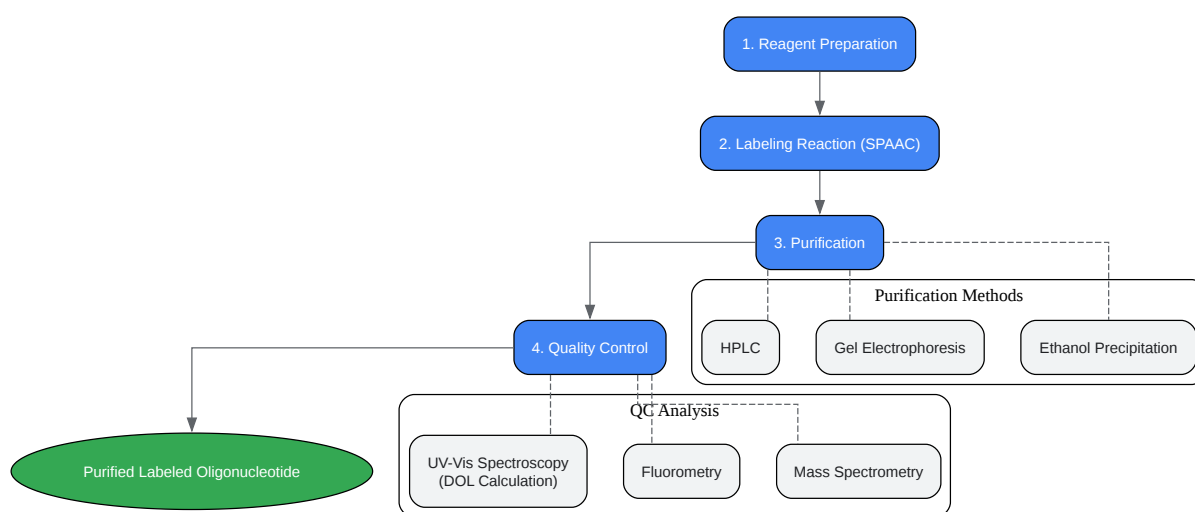
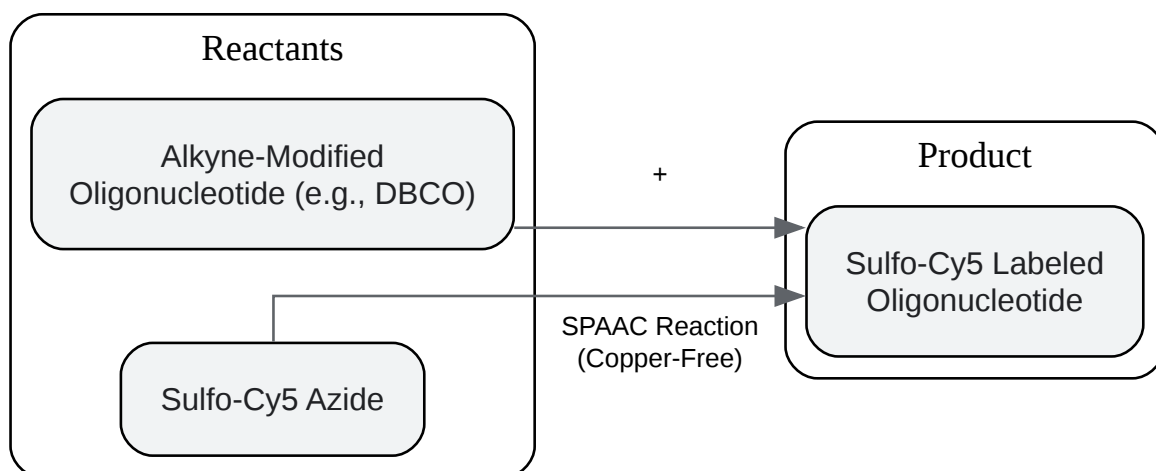

[Click to download full resolution via product page](#)

### Need Custom Synthesis?

BenchChem offers custom synthesis for rare earth carbides and specific isotopic labeling.

Email: [info@benchchem.com](mailto:info@benchchem.com) or [Request Quote Online](#).

## References

- [1. lumiprobe.com \[lumiprobe.com\]](https://lumiprobe.com)
- [2. Oligonucleotide Tagging for Copper-Free Click Conjugation - PMC \[pmc.ncbi.nlm.nih.gov\]](https://pubmed.ncbi.nlm.nih.gov/16111111/)
- [3. Strain-promoted "click" chemistry for terminal labeling of DNA - PMC \[pmc.ncbi.nlm.nih.gov\]](https://pubmed.ncbi.nlm.nih.gov/16111111/)
- [4. experts.umn.edu \[experts.umn.edu\]](https://experts.umn.edu)
- [5. bioconjugation.bocsci.com \[bioconjugation.bocsci.com\]](https://bioconjugation.bocsci.com)
- To cite this document: BenchChem. [Application Notes and Protocols: Labeling Oligonucleotides with Sulfo-Cy5 Azide]. BenchChem, [2026]. [Online PDF]. Available at: [\[https://www.benchchem.com/product/b12395390/docs#application-notes-and-protocols-labeling-oligonucleotides-with-sulfo-cy5-azide\]](https://www.benchchem.com/product/b12395390/docs#application-notes-and-protocols-labeling-oligonucleotides-with-sulfo-cy5-azide)

---

### Disclaimer & Data Validity:

The information provided in this document is for Research Use Only (RUO) and is strictly not intended for diagnostic or therapeutic procedures. While BenchChem strives to provide accurate protocols, we make no warranties, express or implied, regarding the fitness of this product for every specific experimental setup.

**Technical Support:** The protocols provided are for reference purposes. Unsure if this reagent suits your experiment?

**Need Industrial/Bulk Grade?** [Request Custom Synthesis Quote](#)

# BenchChem

Our mission is to be the trusted global source of essential and advanced chemicals, empowering scientists and researchers to drive progress in science and industry.

## Contact

Address: 3281 E Guasti Rd

Ontario, CA 91761, United States

Phone: (601) 213-4426

Email: [info@benchchem.com](mailto:info@benchchem.com)

[Contact our Ph.D. Support Team for a compatibility check](#)