

Application Notes: Conjugation of Cy7.5 Maleimide to Nanoparticles

Author: BenchChem Technical Support Team. **Date:** April 2026

Compound of Interest

Compound Name: Cy7.5 maleimide

Cat. No.: B12395584

[Get Quote](#)

For Researchers, Scientists, and Drug Development Professionals

This document provides a comprehensive guide to the conjugation of the near-infrared (NIR) fluorescent dye, **Cy7.5 maleimide**, to various nanoparticles. This process is critical for the development of advanced imaging agents for preclinical and clinical research, enabling sensitive and non-invasive tracking of nanoparticles in biological systems.

Introduction to Cy7.5 Maleimide Conjugation

The conjugation of **Cy7.5 maleimide** to nanoparticles is a widely used strategy to render them fluorescent for in vivo imaging applications. Cy7.5 is a near-infrared dye with an excitation maximum around 750 nm and an emission maximum around 773 nm. This spectral range is advantageous for in vivo imaging due to reduced tissue autofluorescence and deeper tissue penetration of light.

The maleimide functional group on the Cy7.5 dye reacts specifically with free sulfhydryl (thiol) groups on the surface of nanoparticles, forming a stable thioether bond. This covalent conjugation is highly efficient and site-specific, making it a preferred method for labeling various types of nanoparticles, including:

- **Polymeric Nanoparticles:** Such as those made from PLGA, PLA, or PEGylated polymers, which can be functionalized with thiol groups.
- **Liposomes:** Where thiol-modified lipids can be incorporated into the lipid bilayer.
- **Gold Nanoparticles:** Which can be coated with thiol-containing ligands.
- **Protein-based Nanoparticles:** Utilizing the thiol groups of cysteine residues.

Key Considerations for Successful Conjugation

Several factors must be carefully controlled to ensure efficient and stable conjugation of **Cy7.5 maleimide** to nanoparticles:

- **Availability of Thiol Groups:** The nanoparticle surface must possess accessible free thiol groups. For nanoparticles that have disulfide bonds (e.g., some proteins), a reduction step using reagents like Dithiothreitol (DTT) or Tris(2-carboxyethyl)phosphine (TCEP) is necessary prior to conjugation.
- **Reaction pH:** The maleimide-thiol reaction is most efficient in the pH range of 6.5-7.5. At pH values below 6.5, the reaction rate is significantly reduced, while at pH values above 7.5, the maleimide group can undergo hydrolysis, rendering it unreactive.
- **Molar Ratio of Dye to Nanoparticle:** The ratio of **Cy7.5 maleimide** to the thiol groups on the nanoparticles is a critical parameter that influences the degree of labeling. An excess of the dye is typically used to drive the reaction to completion, but excessive amounts can lead to quenching and should be optimized for each specific nanoparticle system.
- **Reaction Time and Temperature:** The conjugation reaction is typically carried out at room temperature for 2 hours or at 4°C overnight. The optimal time should be determined empirically.
- **Purification:** After the conjugation reaction, it is crucial to remove any unreacted, free **Cy7.5 maleimide**. This is commonly achieved through techniques like size-exclusion chromatography (e.g., Sephadex columns), dialysis, or centrifugation.

- **Stability of the Conjugate:** The stability of the final Cy7.5-nanoparticle conjugate should be assessed, particularly in biologically relevant media (e.g., serum-containing media), as dye detachment can lead to misleading imaging results.

Characterization of Cy7.5-Labeled Nanoparticles

Thorough characterization of the fluorescently labeled nanoparticles is essential to ensure their quality and suitability for in vivo applications. Key characterization techniques include:

- **UV-Vis Spectroscopy:** To confirm the presence of both the nanoparticle and the Cy7.5 dye and to quantify the degree of labeling. The absorbance of the nanoparticle (e.g., surface plasmon resonance for gold nanoparticles) and the characteristic absorbance of Cy7.5 (around 750 nm) are measured.
- **Dynamic Light Scattering (DLS):** To determine the hydrodynamic diameter and size distribution of the nanoparticles before and after conjugation. An increase in size is expected upon conjugation.
- **Zeta Potential Measurement:** To assess the surface charge of the nanoparticles. Changes in zeta potential can indicate successful surface modification.
- **Fluorimetry:** To confirm the fluorescence properties of the conjugated nanoparticles and to determine the fluorescence quantum yield.
- **Transmission Electron Microscopy (TEM):** To visualize the morphology and size of the nanoparticles.

Data Presentation

The following tables summarize typical quantitative data obtained during the conjugation of **Cy7.5 maleimide** to different types of nanoparticles. These values should be considered as a general guide, and optimal conditions may vary depending on the specific nanoparticle system and experimental setup.

Table 1: Reaction Conditions for **Cy7.5 Maleimide** Conjugation

| Nanoparticle Type | Molar Ratio (Dye:Thiol) | pH | Reaction Buffer | Temperature (°C) | Time (hours) | Reference |
|-----------------------|-------------------------|-----------|------------------|-----------------------|---------------|-----------|
| PLGA Nanoparticles | 2:1 to 5:1 | 7.0 - 7.4 | HEPES, PBS | Room Temperature | 0.5 - 2 | [1] |
| Gold Nanoparticles | 10:1 to 20:1 | 7.0 - 7.5 | Phosphate Buffer | Room Temperature | 1 - 2 | [2][3] |
| Liposomes | 5:1 to 10:1 | 7.2 | PBS | Room Temperature | 2 | [4] |
| Protein Nanoparticles | 10:1 to 20:1 | 7.0 - 7.5 | Phosphate Buffer | 4 or Room Temperature | 2 - overnight | [3] |

Table 2: Characterization of Nanoparticles Before and After Cy7.5 Conjugation

| Nanoparticle Type | Parameter | Before Conjugation | After Conjugation | Reference |
|-------------------------|----------------------------|--------------------|-------------------|-----------|
| Polymeric Nanoparticles | Hydrodynamic Diameter (nm) | 120 ± 10.1 | 140 ± 14.7 | [5] |
| Zeta Potential (mV) | -25.3 ± 2.1 | -19.8 ± 1.5 | [5] | |
| Gold Nanoparticles | Hydrodynamic Diameter (nm) | 13.04 ± 1.33 | ~15-20 | [6] |
| Zeta Potential (mV) | -35.8 ± 1.17 | -40 to -50 | [6] | |
| Liposomes | Hydrodynamic Diameter (nm) | 196 ± 3 | 205 ± 5 | [4] |
| Zeta Potential (mV) | +45 ± 1.02 | +42 ± 1.5 | [4] | |

Table 3: Stability of Cy7.5-Nanoparticle Conjugates

| Nanoparticle Type | Medium | Incubation Time | Stability Observation | Reference |
|-------------------------|--------------------|-----------------|---|-----------|
| Polymeric Nanoparticles | PBS with 10% Serum | 24 hours | No significant aggregation or dye release | [7][8] |
| Gold Nanoparticles | Cell Culture Media | 48 hours | Stable with minimal aggregation | [7] |
| Liposomes | Human Serum | 24 hours | Structurally stable with no significant dye leakage | [9] |

Experimental Protocols

This section provides detailed, step-by-step protocols for the conjugation of **Cy7.5 maleimide** to nanoparticles.

Protocol 1: General Protocol for Cy7.5 Maleimide Conjugation to Thiolated Nanoparticles

Materials:

- Thiolated Nanoparticles (e.g., polymeric nanoparticles, liposomes, or surface-modified gold nanoparticles)
- **Cy7.5 maleimide**
- Anhydrous Dimethylsulfoxide (DMSO)
- Reaction Buffer: 100 mM Phosphate Buffer or HEPES buffer, pH 7.0-7.5, degassed
- Reducing Agent (optional, for disulfide bond reduction): DTT or TCEP
- Purification Column (e.g., Sephadex G-25) or centrifugal filter units
- Phosphate Buffered Saline (PBS), pH 7.4

Procedure:

- Preparation of Nanoparticle Solution:
 - Disperse the thiolated nanoparticles in the degassed reaction buffer to a final concentration of 1-10 mg/mL.
 - (Optional) If the nanoparticles contain disulfide bonds, add a 10-100 fold molar excess of TCEP and incubate for 30-60 minutes at room temperature to reduce the disulfide bonds to free thiols. If using DTT, the excess DTT must be removed by dialysis or a desalting column before adding the maleimide dye.
- Preparation of **Cy7.5 Maleimide** Stock Solution:

- Dissolve **Cy7.5 maleimide** in anhydrous DMSO to prepare a 10 mM stock solution. Vortex briefly to ensure complete dissolution. Store any unused solution in the dark at -20°C.
- Conjugation Reaction:
 - Add the **Cy7.5 maleimide** stock solution to the nanoparticle solution. The recommended molar ratio of dye to thiol groups is typically between 10:1 and 20:1, but this should be optimized for each specific nanoparticle system.
 - Gently mix the reaction mixture and incubate for 2 hours at room temperature or overnight at 4°C, protected from light.
- Purification of the Conjugate:
 - Remove the unreacted **Cy7.5 maleimide** by passing the reaction mixture through a pre-equilibrated size-exclusion chromatography column (e.g., Sephadex G-25). Elute with PBS (pH 7.4).
 - Alternatively, use centrifugal filter units with an appropriate molecular weight cutoff to wash the nanoparticles and remove the free dye.
- Characterization:
 - Characterize the purified Cy7.5-nanoparticle conjugate using UV-Vis spectroscopy, DLS, and zeta potential measurements as described in the characterization section.
- Storage:
 - Store the final conjugate solution protected from light at 4°C. For long-term storage, consider adding a cryoprotectant and storing at -20°C or -80°C.

Mandatory Visualizations

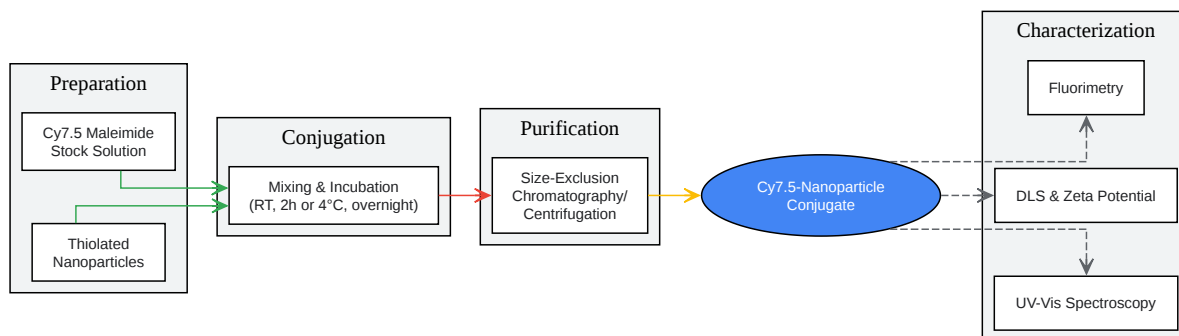

[Click to download full resolution via product page](#)

Caption: Experimental workflow for the conjugation of **Cy7.5 maleimide** to nanoparticles.

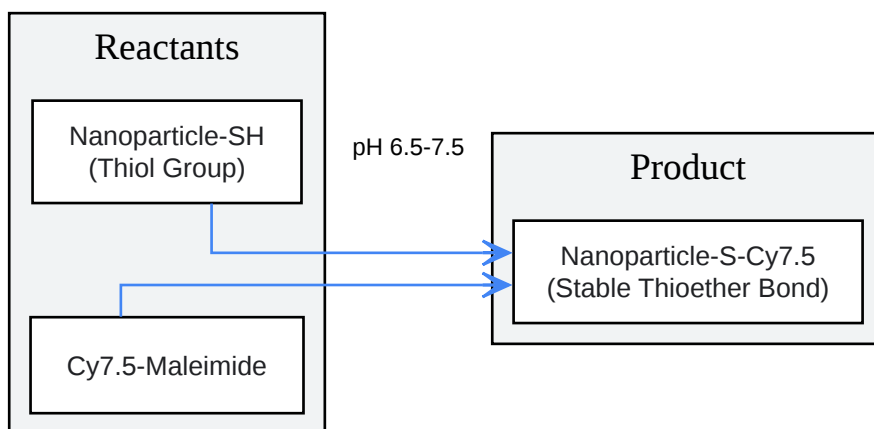

[Click to download full resolution via product page](#)

Caption: Chemical reaction scheme for maleimide-thiol conjugation.

Need Custom Synthesis?

BenchChem offers custom synthesis for rare earth carbides and specific isotopic labeling.

Email: info@benchchem.com or [Request Quote Online](#).

References

- [1. lumiprobe.com \[lumiprobe.com\]](https://lumiprobe.com)
- [2. portal.cytodocs.com \[portal.cytodocs.com\]](https://portal.cytodocs.com)
- [3. interchim.fr \[interchim.fr\]](https://interchim.fr)
- [4. Development of the observation of membrane fusion with label-free liposomes by calcium imaging - PMC \[pmc.ncbi.nlm.nih.gov\]](#)
- [5. researchgate.net \[researchgate.net\]](https://researchgate.net)
- [6. Cellular Delivery of Functional AntimiR Conjugated to Bio-Produced Gold Nanoparticles \[mdpi.com\]](#)
- [7. chalcogen.ro \[chalcogen.ro\]](https://chalcogen.ro)
- [8. rroeder.nd.edu \[rroeder.nd.edu\]](https://rroeder.nd.edu)
- [9. Following the Fate of Dye-Containing Liposomes In Vitro - PMC \[pmc.ncbi.nlm.nih.gov\]](#)
- To cite this document: BenchChem. [Application Notes: Conjugation of Cy7.5 Maleimide to Nanoparticles]. BenchChem, [2026]. [Online PDF]. Available at: [\[https://www.benchchem.com/product/b12395584/docs#application-notes-conjugation-of-cy7-5-maleimide-to-nanoparticles\]](https://www.benchchem.com/product/b12395584/docs#application-notes-conjugation-of-cy7-5-maleimide-to-nanoparticles)

Disclaimer & Data Validity:

The information provided in this document is for Research Use Only (RUO) and is strictly not intended for diagnostic or therapeutic procedures. While BenchChem strives to provide accurate protocols, we make no warranties, express or implied, regarding the fitness of this product for every specific experimental setup.

Technical Support: The protocols provided are for reference purposes. Unsure if this reagent suits your experiment?

Need Industrial/Bulk Grade? [Request Custom Synthesis Quote](#)

BenchChem

Our mission is to be the trusted global source of essential and advanced chemicals, empowering scientists and researchers to drive progress in science and industry.

Contact

Address: 3281 E Guasti Rd

Ontario, CA 91761, United States

Phone: (601) 213-4426

Email: info@benchchem.com

[Contact our Ph.D. Support Team for a compatibility check](#)