

Orexin A (16-33): A Technical Guide for Researchers

Author: BenchChem Technical Support Team. **Date:** April 2026

Compound of Interest

Compound Name: Orexin A (16-33)

Cat. No.: B12394946

[Get Quote](#)

An In-depth Whitepaper on a Key Fragment of Orexin A for Use in Neuroscience and Drug Discovery

Introduction

Orexin A, also known as hypocretin-1, is a 33-amino acid neuropeptide that plays a critical role in the regulation of arousal, wakefulness, and appetite.[1] It exerts its effects through two G protein-coupled receptors (GPCRs), the orexin-1 receptor (OX1R) and the orexin-2 receptor (OX2R).[1] **Orexin A (16-33)** is a C-terminal fragment of the full-length orexin A peptide.[2][3] While N-terminally truncated forms of orexin A are generally less potent than the full-length peptide, they retain biological activity and serve as valuable research tools for investigating the orexin system.[4] This technical guide provides a comprehensive overview of **Orexin A (16-33)** for researchers, scientists, and drug development professionals, with a focus on its pharmacological properties, experimental applications, and the underlying signaling mechanisms.

Pharmacological Profile of Orexin Peptides

The orexin peptides, including Orexin A and its fragments, exhibit distinct binding affinities and functional potencies at the two orexin receptors. This differential activity is crucial for dissecting

the specific roles of OX1R and OX2R in various physiological processes.

Compound	Receptor	Assay Type	Potency (pEC50)	Potency (EC50 in nM)	Reference
Orexin A (16-33)	OX1R	ERK1/2 Phosphorylation	5.72 ± 0.09	~1905	
Orexin A	OX1R	ERK1/2 Phosphorylation	7.53 ± 0.12	~29.5	
Orexin B	OX1R	ERK1/2 Phosphorylation	6.50 ± 0.33	~316	
Orexin A	OX1R	Noradrenaline Release	8.74 ± 0.32	1.8	
Orexin B	OX1R	Noradrenaline Release	8.61 ± 0.38	2.4	
Orexin A (17-33)	OX1R	Functional Assay	-	8.29	
Orexin A (17-33)	OX2R	Functional Assay	-	187	

Signaling Pathways

Activation of orexin receptors initiates distinct downstream signaling cascades, primarily dependent on the receptor subtype and the G protein to which it couples.

OX1R Signaling Pathway

The orexin 1 receptor (OX1R) predominantly couples to the Gq class of G proteins. Upon agonist binding, this initiates a signaling cascade that leads to the activation of phospholipase C (PLC), subsequent production of inositol trisphosphate (IP3) and diacylglycerol (DAG), and a

resultant increase in intracellular calcium concentration. This calcium signaling is a hallmark of OX1R activation.

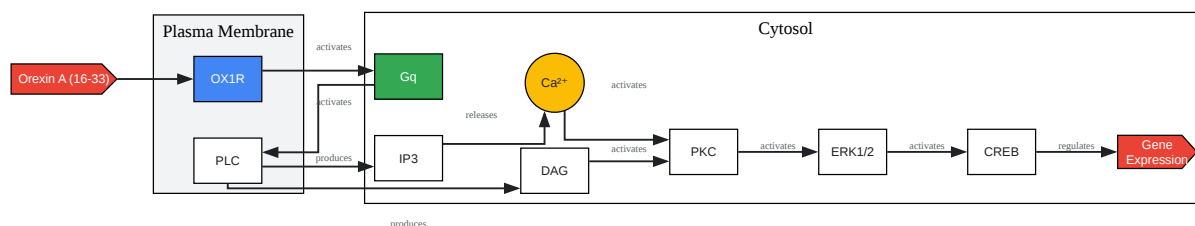

[Click to download full resolution via product page](#)

Caption: OX1R Gq-mediated signaling cascade.

OX2R Signaling Pathways

The orexin 2 receptor (OX2R) exhibits more diverse signaling by coupling to Gq, Gi/o, and Gs proteins. This allows OX2R activation to influence both intracellular calcium levels and cyclic adenosine monophosphate (cAMP) concentrations, leading to a broader range of cellular responses.

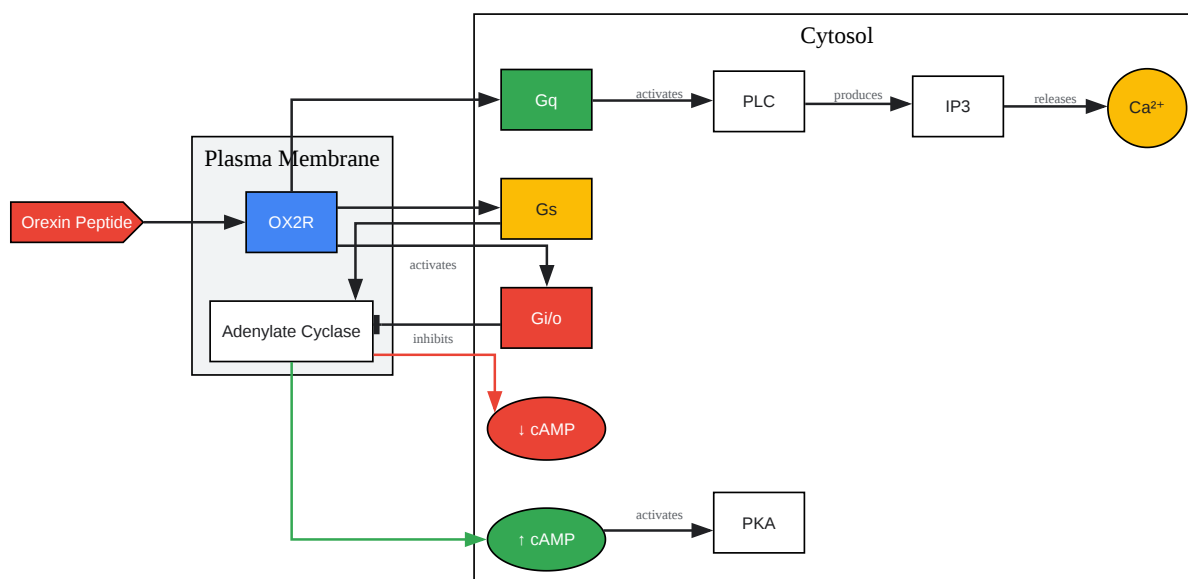

[Click to download full resolution via product page](#)

Caption: Diverse signaling pathways of the OX2R.

Experimental Protocols

Detailed methodologies are essential for the reproducible application of **Orexin A (16-33)** in research. Below are representative protocols for key in vitro assays.

Calcium Mobilization Assay

This assay measures the increase in intracellular calcium following orexin receptor activation, a primary readout for Gq-coupled GPCRs like OX1R.

1. Cell Culture and Plating:

- Culture Chinese Hamster Ovary (CHO) or Human Embryonic Kidney (HEK293) cells stably expressing the human orexin receptor of interest (OX1R or OX2R) in appropriate growth medium.
- Seed cells into black-walled, clear-bottom 96-well plates at a density that will result in a confluent monolayer on the day of the assay.
- Incubate plates at 37°C in a 5% CO₂ incubator for 24 hours.

2. Dye Loading:

- Prepare a loading buffer containing a calcium-sensitive fluorescent dye (e.g., Fluo-4 AM) in a physiological salt solution (e.g., Hanks' Balanced Salt Solution with 20 mM HEPES).
- Remove the growth medium from the cell plates and add the dye-loading buffer to each well.
- Incubate the plates for 45-60 minutes at 37°C, protected from light.

3. Compound Preparation and Addition:

- Prepare a stock solution of **Orexin A (16-33)** in an appropriate solvent (e.g., sterile water or DMSO).
- Perform serial dilutions of the peptide in the assay buffer to create a concentration range for generating a dose-response curve.
- Utilize a fluorescent plate reader with automated injection capabilities (e.g., FLIPR or FlexStation) to add the **Orexin A (16-33)** solutions to the wells.

4. Data Acquisition and Analysis:

- Measure the fluorescence intensity before and after the addition of the agonist.
- Record the change in fluorescence over time to capture the kinetic response.
- Calculate the peak fluorescence response for each concentration and plot the dose-response curve.
- Determine the EC₅₀ value by fitting the data to a sigmoidal dose-response curve using appropriate software (e.g., GraphPad Prism).

ERK1/2 Phosphorylation Assay

This assay quantifies the activation of the Mitogen-Activated Protein Kinase (MAPK) pathway, a common downstream signaling event for many GPCRs.

1. Cell Culture and Treatment:

- Plate and culture orexin receptor-expressing cells as described for the calcium mobilization assay.
- On the day of the experiment, replace the growth medium with a serum-free medium and starve the cells for 4-6 hours.
- Treat the cells with various concentrations of **Orexin A (16-33)** for a predetermined time (e.g., 5-10 minutes) at 37°C.

2. Cell Lysis:

- Aspirate the medium and wash the cells with ice-cold phosphate-buffered saline (PBS).
- Add lysis buffer containing protease and phosphatase inhibitors to each well and incubate on ice to lyse the cells.
- Collect the cell lysates and determine the protein concentration using a standard protein assay (e.g., BCA assay).

3. Western Blotting or ELISA:

- Western Blotting:
 - Separate the protein lysates by SDS-PAGE and transfer them to a PVDF membrane.
 - Block the membrane with a suitable blocking buffer (e.g., 5% non-fat milk or BSA in TBST).
 - Incubate the membrane with primary antibodies specific for phosphorylated ERK1/2 (p-ERK) and total ERK1/2.
 - Wash the membrane and incubate with a horseradish peroxidase (HRP)-conjugated secondary antibody.
 - Detect the protein bands using an enhanced chemiluminescence (ECL) substrate and image the blot.
 - Quantify the band intensities and normalize the p-ERK signal to the total ERK signal.
- ELISA:
 - Utilize a commercially available ERK1/2 phosphorylation ELISA kit.
 - Add cell lysates to the wells of the ELISA plate pre-coated with a capture antibody for total ERK1/2.
 - Add a detection antibody for p-ERK, followed by an HRP-conjugated secondary antibody and substrate.
 - Measure the absorbance or fluorescence and calculate the relative levels of p-ERK.

4. Data Analysis:

- Plot the normalized p-ERK levels against the concentration of **Orexin A (16-33)**.

- Determine the EC50 value from the resulting dose-response curve.

Experimental Workflow

The following diagram illustrates a typical workflow for screening and characterizing the activity of **Orexin A (16-33)** on orexin receptors.

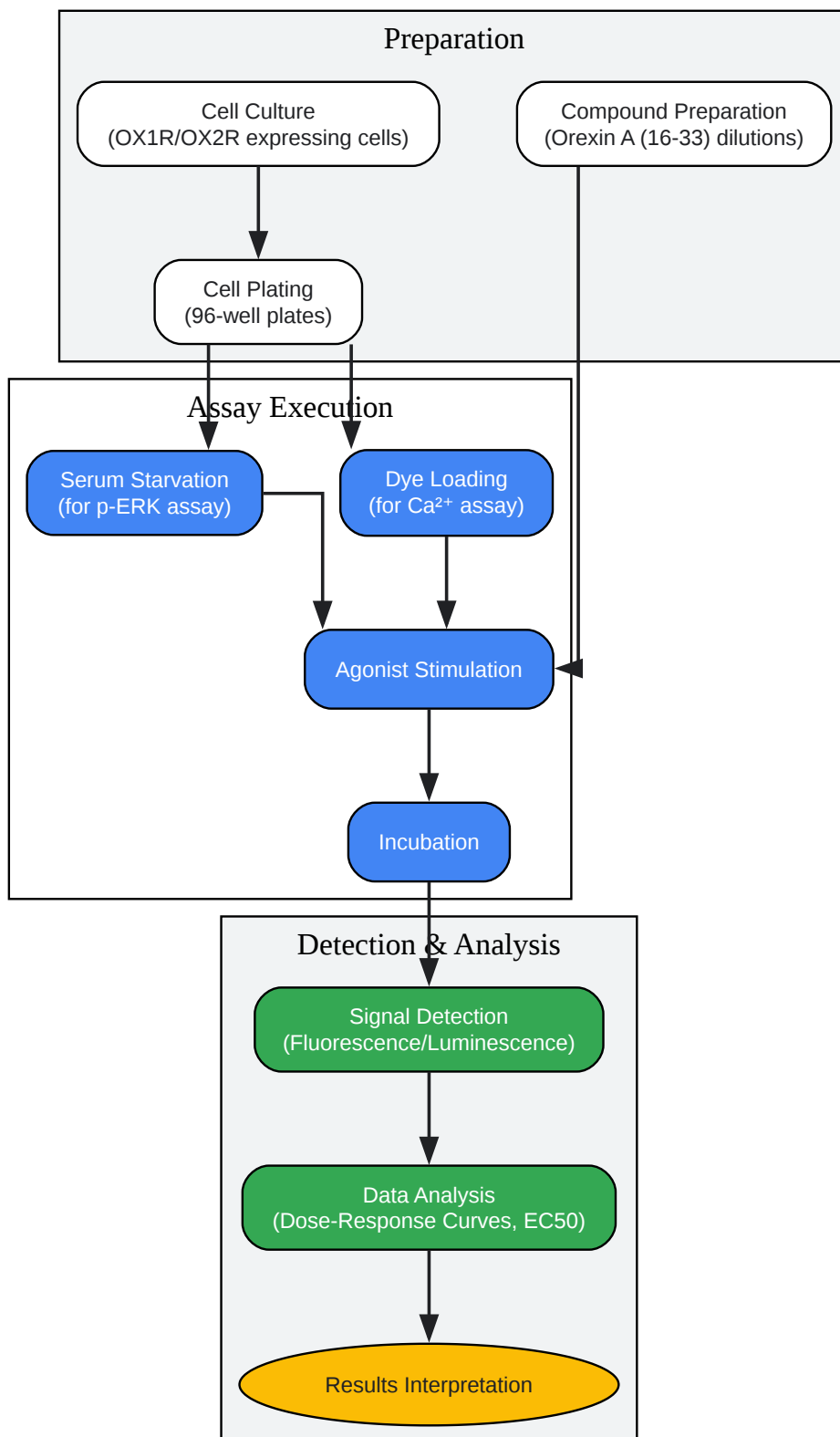

[Click to download full resolution via product page](#)

Caption: A typical workflow for in vitro functional assays.

Conclusion

Orexin A (16-33) serves as a valuable research tool for elucidating the complex roles of the orexin system. While less potent than the full-length Orexin A, its activity, particularly at the OX1R, allows for targeted investigations into the physiological functions mediated by this receptor. The detailed protocols and signaling pathway information provided in this guide are intended to facilitate the effective use of **Orexin A (16-33)** in neuroscience research and the development of novel therapeutics targeting the orexin system.

Need Custom Synthesis?

BenchChem offers custom synthesis for rare earth carbides and specific isotopic labeling.

Email: info@benchchem.com or [Request Quote Online](#).

References

- [1. Orexin - Wikipedia \[en.wikipedia.org\]](#)
- [2. medchemexpress.com \[medchemexpress.com\]](#)
- [3. medchemexpress.com \[medchemexpress.com\]](#)
- [4. Intramolecular Fluorescence Resonance Energy Transfer \(FRET\) Sensors of the Orexin OX1 and OX2 Receptors Identify Slow Kinetics of Agonist Activation - PMC \[pmc.ncbi.nlm.nih.gov\]](#)
- To cite this document: BenchChem. [Orexin A (16-33): A Technical Guide for Researchers]. BenchChem, [2026]. [Online PDF]. Available at: [\[https://www.benchchem.com/product/b12394946/docs#orexin-a-16-33-a-technical-guide-for-researchers\]](https://www.benchchem.com/product/b12394946/docs#orexin-a-16-33-a-technical-guide-for-researchers)

Disclaimer & Data Validity:

The information provided in this document is for Research Use Only (RUO) and is strictly not intended for diagnostic or therapeutic procedures. While BenchChem strives to provide accurate protocols, we make no warranties, express or implied, regarding the fitness of this product for every specific experimental setup.

Technical Support: The protocols provided are for reference purposes. Unsure if this reagent suits your experiment?

Need Industrial/Bulk Grade? [Request Custom Synthesis Quote](#)

BenchChem

Our mission is to be the trusted global source of essential and advanced chemicals, empowering scientists and researchers to drive progress in science and industry.

Contact

Address: 3281 E Guasti Rd
Ontario, CA 91761, United States
Phone: (601) 213-4426
Email: info@benchchem.com

[Contact our Ph.D. Support Team for a compatibility check](#)