

Technical Support Center: Cdk9-IN-22

Resistance Mechanisms

Author: BenchChem Technical Support Team. **Date:** April 2026

Compound of Interest

Compound Name: Cdk9-IN-22

Cat. No.: B12393609

[Get Quote](#)

This technical support center provides troubleshooting guidance and frequently asked questions (FAQs) for researchers encountering resistance to CDK9 inhibitors, with a focus on mechanisms potentially relevant to **Cdk9-IN-22**.

Disclaimer: While the following information is based on published research on CDK9 inhibitor resistance, specific studies on **Cdk9-IN-22** resistance mechanisms are limited. The mechanisms described are based on studies with other CDK9 inhibitors like BAY1251152 and flavopiridol and are presented here as probable mechanisms for **Cdk9-IN-22** resistance.

Frequently Asked Questions (FAQs)

Q1: What are the known mechanisms of acquired resistance to CDK9 inhibitors in cancer cells?

A1: Acquired resistance to CDK9 inhibitors can arise through several mechanisms, including:

- Target-based mutations: A primary mechanism is the emergence of mutations in the CDK9 kinase domain. For instance, the L156F mutation has been identified to confer resistance to the CDK9 inhibitor BAY1251152 by sterically hindering inhibitor binding.^{[1][2]} This mutation may also affect the thermal stability and catalytic activity of the CDK9 protein.^{[1][2]}

- Upregulation of downstream survival pathways: Cancer cells can develop resistance by upregulating pro-survival proteins that are normally suppressed by CDK9 inhibition. A key example is the stabilization of the anti-apoptotic protein Mcl-1.[3][4][5]
- Activation of alternative signaling pathways: The activation of pathways like the MAPK/ERK pathway can contribute to Mcl-1 stabilization and promote resistance.[3][4]
- Increased CDK9 kinase activity: Resistant cells may exhibit an increase in the phosphorylation of the RNA Polymerase II C-terminal domain and an overall increase in CDK9 kinase activity to counteract the effects of the inhibitor.[3][4]

Q2: My cancer cell line is showing reduced sensitivity to **Cdk9-IN-22** over time. What is the likely cause?

A2: Reduced sensitivity, or acquired resistance, is often the result of selective pressure from the drug. The most common causes are the development of a resistant subpopulation of cells that harbor mutations in the drug target (CDK9) or the activation of bypass signaling pathways that promote cell survival despite CDK9 inhibition.[1] We recommend investigating for the L156F mutation in CDK9 and assessing the expression and stability of Mcl-1.

Q3: Are there any known mutations in CDK9 that confer resistance to inhibitors?

A3: Yes, the L156F mutation in the kinase domain of CDK9 has been shown to drive resistance to CDK9 inhibitors, including both ATP-competitive inhibitors and PROTAC degraders.[1][2] This mutation is a coding single nucleotide polymorphism (SNP) and can be identified through genomic sequencing.[1][2]

Q4: How does Mcl-1 contribute to resistance against CDK9 inhibitors?

A4: CDK9 is a key regulator of the transcription of short-lived proteins, including the anti-apoptotic protein Mcl-1.[1] Inhibition of CDK9 typically leads to a rapid decrease in Mcl-1 levels, inducing apoptosis in cancer cells. In resistant cells, Mcl-1 protein stability is often prolonged, for instance, through activation of the MAPK/ERK pathway, allowing the cells to evade apoptosis despite CDK9 inhibition.[3][4][5]

Troubleshooting Guide

Problem	Possible Cause	Suggested Solution
Decreased cell death observed with Cdk9-IN-22 treatment over subsequent experiments.	Development of a resistant cell population.	<ol style="list-style-type: none">1. Sequence the CDK9 gene in your resistant cell line to check for mutations, particularly L156F.[1][2]2. Perform a Western blot to assess the levels of Mcl-1 and phosphorylated ERK in treated vs. untreated resistant cells.[3]3. Consider combination therapy with an ERK inhibitor or an Mcl-1 inhibitor.
No significant downregulation of downstream targets (e.g., MYC, Mcl-1) upon Cdk9-IN-22 treatment in a previously sensitive cell line.	Altered drug-target engagement due to mutation or efflux pump activity.	<ol style="list-style-type: none">1. Confirm target engagement by assessing the phosphorylation of the RNA Polymerase II C-terminal domain (a direct substrate of CDK9).[3]2. If a mutation like L156F is present, consider using a next-generation CDK9 inhibitor designed to overcome this resistance.[1][2]3. Evaluate the expression of ABC transporters which can mediate drug efflux.
Inconsistent IC50 values for Cdk9-IN-22 in proliferation assays.	Experimental variability or emergence of a heterogeneous population.	<ol style="list-style-type: none">1. Standardize your cell viability assay protocol, including cell seeding density and drug treatment duration.[6]2. Perform single-cell cloning to isolate and characterize subpopulations with varying sensitivity.3. Regularly check for mycoplasma contamination,

which can affect drug sensitivity.

Quantitative Data Summary

Table 1: Drug Resistance Index (DRI) of CDK9 Inhibitors in Resistant Cell Lines

Cell Line	Parental Cell Line	CDK9 Inhibitor	GI50 (Parental)	GI50 (Resistant)	DRI (GI50 Resistant / GI50 Parental)	Reference
MOLM13-BR	MOLM13	BAY1251152	10 nM	>1000 nM	>100	[1]
MOLM13-BR	MOLM13	AZD4573	20 nM	500 nM	25	[1]
HeLa CDK9 L156F	HeLa	BAY1251152	~50 nM	>1000 nM	>20	[2]

Table 2: Inhibition Activity (IC50) of Compounds Against Wild-Type and Mutant CDK9

Compound	CDK9 Target	IC50 (nM)	Reference
BAY1251152	CDK9 WT/cyclinT1	5.2	[1]
BAY1251152	CDK9 L156F/cyclinT1	157.3	[1]
IHMT-CDK9-36	CDK9 WT/cyclinT1	1.8	[1]
IHMT-CDK9-36	CDK9 L156F/cyclinT1	3.6	[1]

Key Experimental Protocols

1. Generation of a Drug-Resistant Cell Line

This protocol describes the generation of a resistant cell line through continuous exposure to escalating doses of a drug.[\[8\]](#)[\[9\]](#)

- Materials: Parental cancer cell line, **Cdk9-IN-22**, cell culture medium, flasks, incubators.
- Procedure:
 - Start by treating the parental cell line with **Cdk9-IN-22** at a concentration equal to the IC20 (the concentration that inhibits 20% of cell growth).
 - Culture the cells until they resume a normal growth rate.
 - Gradually increase the concentration of **Cdk9-IN-22** in the culture medium. A 1.5- to 2-fold increase at each step is recommended.[\[8\]](#)
 - If significant cell death occurs, reduce the fold-increase to 1.1- to 1.5-fold.[\[8\]](#)
 - Continue this process of dose escalation and cell recovery for several months.
 - Periodically assess the IC50 of the cell line to monitor the development of resistance. A 3- to 10-fold increase in IC50 compared to the parental line is generally considered indicative of resistance.[\[8\]](#)
 - Once a stable resistant cell line is established, it can be maintained in a medium containing a constant concentration of **Cdk9-IN-22**.

2. Cell Viability (IC50) Determination Assay

This protocol outlines the measurement of drug sensitivity using a standard endpoint assay.[\[6\]](#)
[\[7\]](#)

- Materials: Parental and resistant cell lines, **Cdk9-IN-22**, 96-well plates, cell viability reagent (e.g., CellTiter-Glo®), plate reader.
- Procedure:
 - Seed the cells in a 96-well plate at a predetermined optimal density and allow them to adhere overnight.

- Prepare a serial dilution of **Cdk9-IN-22**. It is advisable to perform a preliminary experiment with a wide concentration range (e.g., 10-fold dilutions) to determine the approximate sensitivity range.[6]
- Add the different concentrations of **Cdk9-IN-22** to the wells. Include a vehicle-only control.
- Incubate the plate for a duration that allows for at least one to two cell divisions (typically 48-72 hours).[6]
- At the end of the incubation period, add the cell viability reagent to each well according to the manufacturer's instructions.
- Measure the luminescence or absorbance using a plate reader.
- Calculate the half-maximal inhibitory concentration (IC50) by fitting the dose-response data to a nonlinear regression curve.

3. Western Blotting for Mcl-1 and Phospho-ERK

This protocol is for assessing the protein levels of key markers in the resistance pathway.

- Materials: Parental and resistant cell lines, **Cdk9-IN-22**, lysis buffer, primary antibodies (anti-Mcl-1, anti-phospho-ERK, anti-total-ERK, anti-GAPDH), secondary antibodies, SDS-PAGE gels, transfer apparatus, imaging system.
- Procedure:
 - Treat parental and resistant cells with **Cdk9-IN-22** at the desired concentration and time points.
 - Lyse the cells and quantify the protein concentration.
 - Separate the protein lysates by SDS-PAGE and transfer them to a PVDF membrane.
 - Block the membrane and incubate with the primary antibodies overnight at 4°C.
 - Wash the membrane and incubate with the appropriate HRP-conjugated secondary antibodies.

- Develop the blot using a chemiluminescence substrate and capture the image.
- Quantify the band intensities and normalize to a loading control like GAPDH.

Signaling Pathways and Workflows

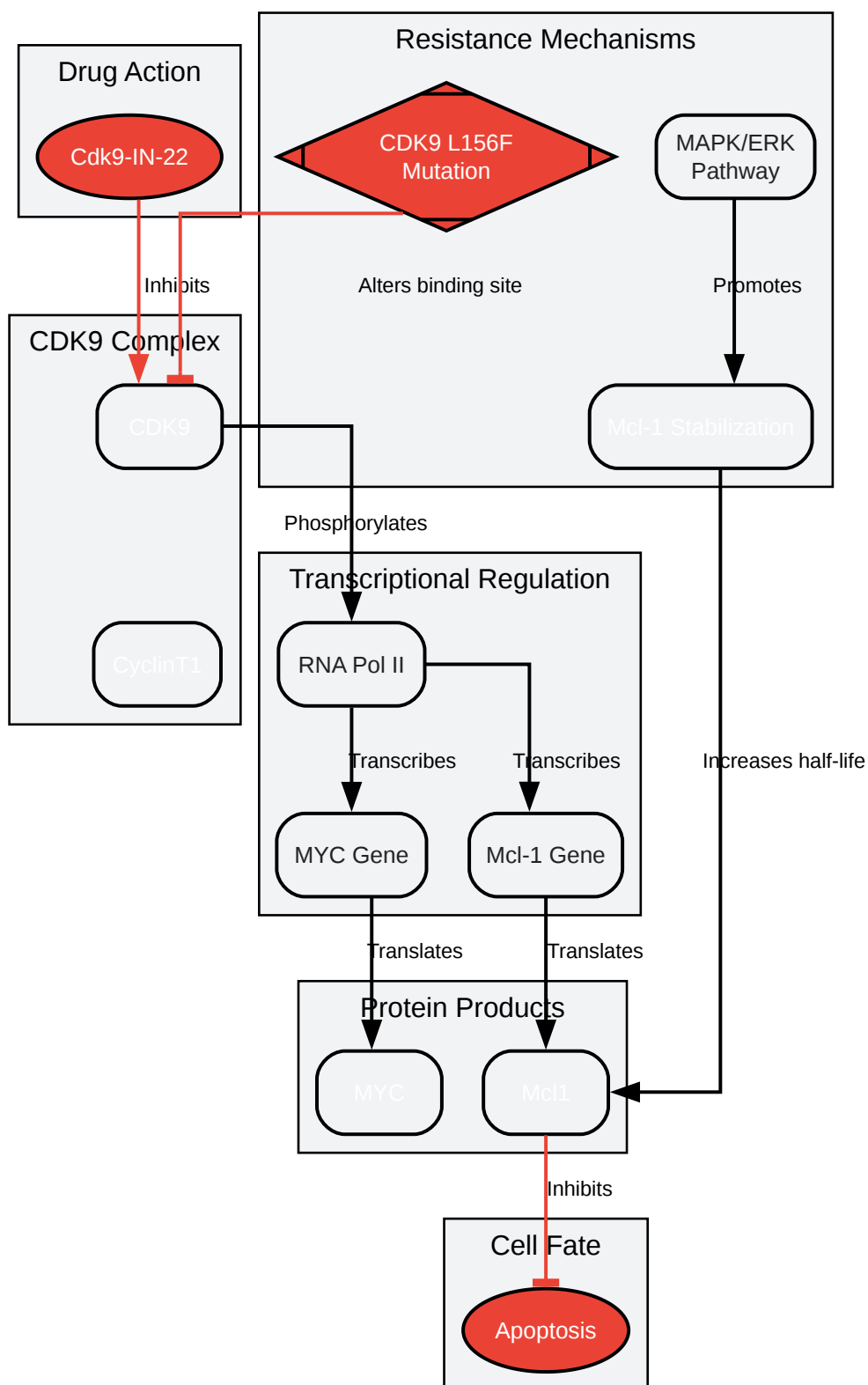

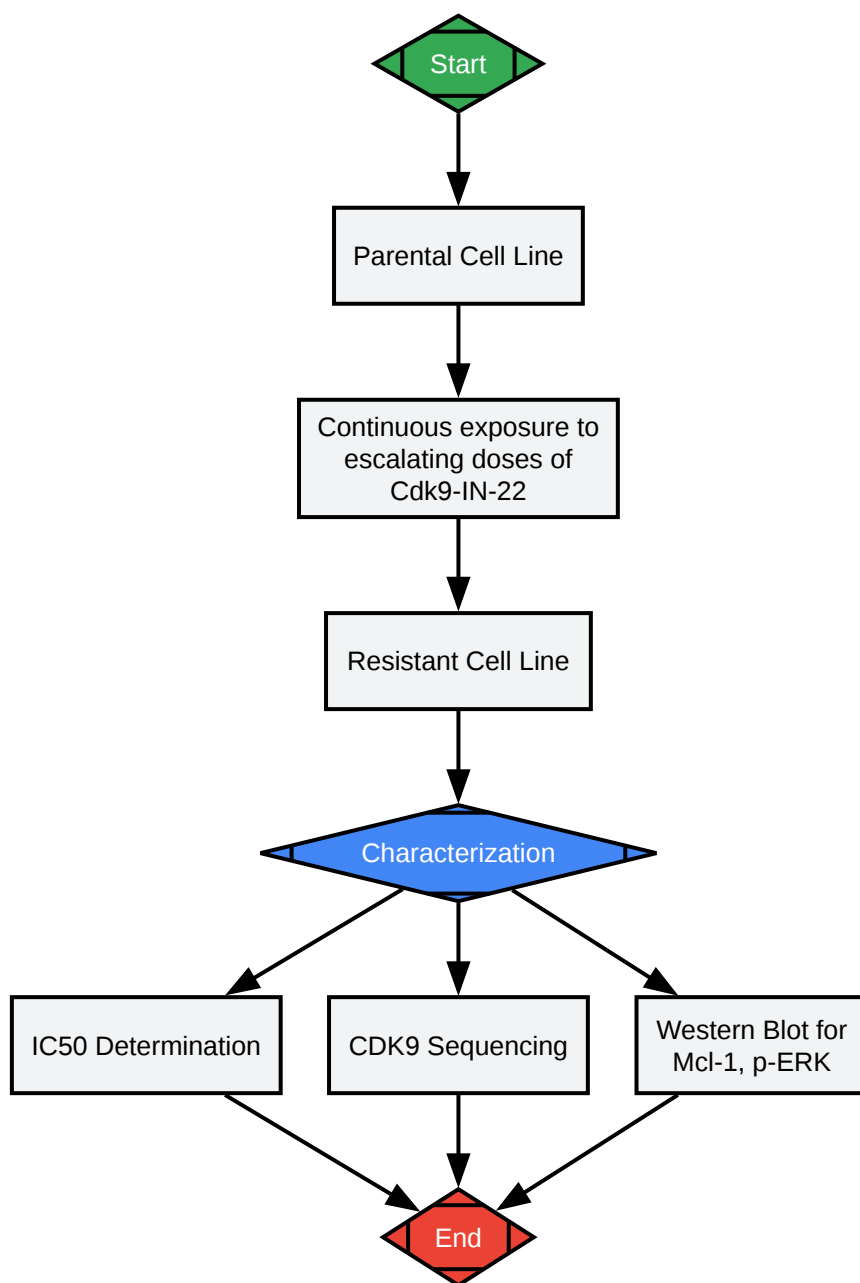

[Click to download full resolution via product page](#)

Need Custom Synthesis?

BenchChem offers custom synthesis for rare earth carbides and specific isotopic labeling.

Email: info@benchchem.com or [Request Quote Online](#).

References

- [1. Predicting and overcoming resistance to CDK9 inhibitors for cancer therapy - PMC \[pmc.ncbi.nlm.nih.gov\]](#)
- [2. lsciences.com \[lsciences.com\]](#)
- [3. Up-regulation of CDK9 kinase activity and Mcl-1 stability contributes to the acquired resistance to cyclin-dependent kinase inhibitors in leukemia - PMC \[pmc.ncbi.nlm.nih.gov\]](#)
- [4. Up-regulation of CDK9 kinase activity and Mcl-1 stability contributes to the acquired resistance to cyclin-dependent kinase inhibitors in leukemia - PubMed \[pubmed.ncbi.nlm.nih.gov\]](#)
- [5. oncotarget.com \[oncotarget.com\]](#)
- [6. sorger.med.harvard.edu \[sorger.med.harvard.edu\]](#)
- [7. Measuring Cancer Drug Sensitivity and Resistance in Cultured Cells - PMC \[pmc.ncbi.nlm.nih.gov\]](#)
- [8. Development of Drug-resistant Cell Lines for Experimental Procedures - PMC \[pmc.ncbi.nlm.nih.gov\]](#)
- [9. blog.crownbio.com \[blog.crownbio.com\]](#)
- [To cite this document: BenchChem. \[Technical Support Center: Cdk9-IN-22 Resistance Mechanisms\]. BenchChem, \[2026\]. \[Online PDF\]. Available at: \[https://www.benchchem.com/product/b12393609/docs#technical-support-center-cdk9-in-22-resistance-mechanisms\]](#)

Disclaimer & Data Validity:

The information provided in this document is for Research Use Only (RUO) and is strictly not intended for diagnostic or therapeutic procedures. While BenchChem strives to provide accurate protocols, we make no warranties, express or implied, regarding the fitness of this product for every specific experimental setup.

Technical Support: The protocols provided are for reference purposes. Unsure if this reagent suits your experiment?

Need Industrial/Bulk Grade? [Request Custom Synthesis Quote](#)

BenchChem

Our mission is to be the trusted global source of essential and advanced chemicals, empowering scientists and researchers to drive progress in science and industry.

Contact

Address: 3281 E Guasti Rd

Ontario, CA 91761, United States

Phone: (601) 213-4426

Email: info@benchchem.com

[Contact our Ph.D. Support Team for a compatibility check](#)