

Application Notes and Protocols for P34cdc2 Kinase Phosphorylation Assays

Author: BenchChem Technical Support Team. **Date:** April 2026

Compound of Interest

Compound Name: P34cdc2 Kinase Fragment

Cat. No.: B12393431

[Get Quote](#)

For Researchers, Scientists, and Drug Development Professionals

Introduction

P34cdc2, also known as Cyclin-Dependent Kinase 1 (CDK1), is a key serine/threonine protein kinase that plays a pivotal role in regulating the eukaryotic cell cycle.[1][2][3][4] Its activity is fundamental for the G2/M transition, initiating the complex series of events leading to mitosis. The kinase activity of P34cdc2 is tightly regulated through its association with regulatory subunits called cyclins, and by a series of activating and inhibitory phosphorylations.[5][6][7][8] Given its critical role in cell proliferation, P34cdc2 is a significant target for the development of novel anti-cancer therapeutics.[9]

These application notes provide detailed protocols for in vitro phosphorylation assays using the **P34cdc2 kinase fragment**, offering a robust system for studying kinase activity, identifying potential substrates, and screening for novel inhibitors.

Signaling Pathway and Regulation of P34cdc2

The activation of P34cdc2 is a multi-step process. It begins with the binding of a cyclin partner, typically Cyclin B for mitotic entry. This complex is then phosphorylated at an activating site

(Threonine 161) by a CDK-activating kinase (CAK).[10] Concurrently, it is phosphorylated at inhibitory sites (Threonine 14 and Tyrosine 15) by Wee1 and Myt1 kinases.[7] The final activation step at the onset of mitosis is the dephosphorylation of these inhibitory sites by the Cdc25 phosphatase.[6]

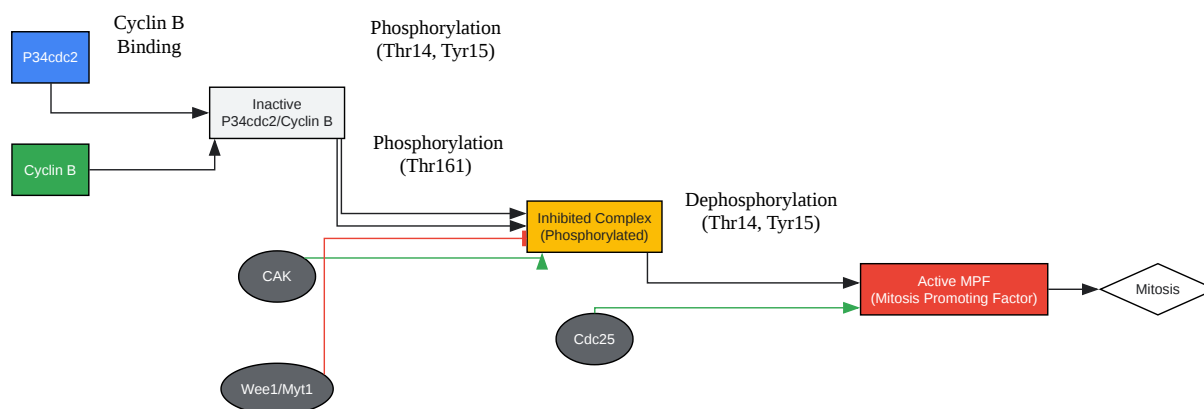

[Click to download full resolution via product page](#)

Caption: Regulation of P34cdc2 Kinase Activity.

Experimental Protocols

Protocol 1: In Vitro Phosphorylation Assay using Histone H1

This protocol describes a classic method to measure the kinase activity of P34cdc2 using a generic substrate, Histone H1, and radiolabeled ATP.

Materials:

- Active P34cdc2/Cyclin B complex

- Histone H1 (from calf thymus)
- Kinase Assay Buffer (5X): 250 mM HEPES pH 7.4, 50 mM MgCl₂, 5 mM DTT, 5 mM EGTA
- ATP Solution: 10 mM ATP in sterile water
- [γ -³²P]ATP (10 μ Ci/ μ l)
- Trichloroacetic Acid (TCA), 25%
- Phosphocellulose paper (P81)
- Scintillation counter and scintillation fluid

Procedure:

- Prepare the Kinase Reaction Mix: For each reaction, prepare a master mix containing:
 - 5 μ l 5X Kinase Assay Buffer
 - 2.5 μ l Histone H1 (1 mg/ml stock)
 - X μ l active P34cdc2/Cyclin B (amount to be optimized)
 - X μ l sterile distilled water to a final volume of 24 μ l.
- Initiate the Reaction: Add 1 μ l of a mix of cold ATP and [γ -³²P]ATP to each reaction tube. A final ATP concentration of 100-200 μ M is recommended.
- Incubation: Incubate the reaction tubes at 30°C for 20-30 minutes.
- Stop the Reaction: Spot 20 μ l of each reaction mixture onto a labeled P81 phosphocellulose paper square.
- Washing:
 - Wash the P81 papers three times for 5 minutes each in a beaker containing 0.75% phosphoric acid.

- Perform one final wash with acetone for 2 minutes to dry the papers.
- Quantification: Place each dried P81 paper in a scintillation vial, add scintillation fluid, and measure the incorporated radioactivity using a scintillation counter.

Protocol 2: In Vitro Phosphorylation Assay using a Synthetic Peptide Substrate

This protocol utilizes a specific peptide substrate for a more targeted and potentially higher throughput assay format. A commonly used peptide is derived from the SV40 large T antigen. [\[11\]](#)

Materials:

- Active P34cdc2/Cyclin B complex
- P34cdc2 Substrate Peptide (e.g., sequence: ADAQHATPPKKKRVKVEDPKDF)[\[12\]](#)
- Kinase Assay Buffer (5X): 250 mM HEPES pH 7.4, 50 mM MgCl₂, 5 mM DTT, 5 mM EGTA
- ATP Solution: 10 mM ATP in sterile water
- [γ -³²P]ATP (10 μ Ci/ μ l)
- Phosphoric acid, 75 mM
- Phosphocellulose paper (P81) or alternative capture method
- Scintillation counter and scintillation fluid

Procedure:

- Reaction Setup: In a microcentrifuge tube, combine:
 - 10 μ l 5X Kinase Assay Buffer
 - 5 μ l P34cdc2 Substrate Peptide (stock concentration to be optimized based on Km)
 - X μ l active P34cdc2/Cyclin B

- 10 μ l ATP mix (containing cold ATP and $[\gamma\text{-}^{32}\text{P}]\text{ATP}$ to a final concentration of 100-200 μM)
- Sterile distilled water to a final volume of 50 μ l.
- Incubation: Incubate at 30°C for 30 minutes.
- Termination and Detection: Follow steps 4-6 from Protocol 1.

Protocol 3: Non-Radioactive Kinase Assay (ADP-Glo™ Kinase Assay)

This protocol provides a non-radioactive alternative for measuring kinase activity by quantifying the amount of ADP produced in the kinase reaction.

Materials:

- Active P34cdc2/Cyclin B complex
- Substrate (Histone H1 or synthetic peptide)
- Kinase Assay Buffer (as described previously, without DTT if using certain commercial kits)
- ATP
- ADP-Glo™ Kinase Assay Kit (Promega) or similar

Procedure:

- Kinase Reaction:
 - Set up the kinase reaction in a 96-well plate. Each well should contain P34cdc2, substrate, ATP, and kinase buffer in a final volume of 25 μ l.
 - Include a "no enzyme" control to determine background ADP levels.
 - Incubate at 30°C for 30-60 minutes.
- ADP Detection:

- Add 25 μ l of ADP-Glo™ Reagent to each well to stop the kinase reaction and deplete the remaining ATP. Incubate for 40 minutes at room temperature.
- Add 50 μ l of Kinase Detection Reagent to convert ADP to ATP and introduce luciferase and luciferin to detect the newly synthesized ATP. Incubate for 30-60 minutes at room temperature.
- Measurement: Measure the luminescence using a plate-reading luminometer. The light output is proportional to the ADP concentration, and therefore to the kinase activity.

Experimental Workflow Diagram

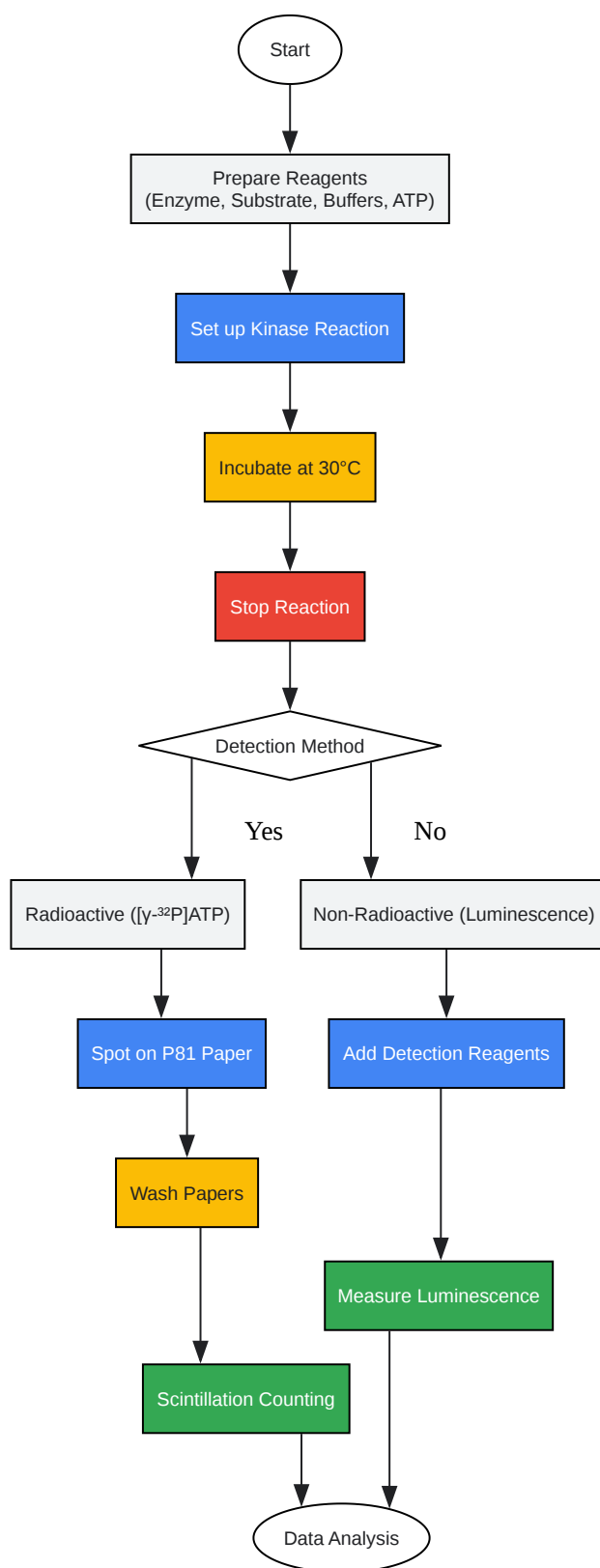

[Click to download full resolution via product page](#)

Need Custom Synthesis?

BenchChem offers custom synthesis for rare earth carbides and specific isotopic labeling.

Email: info@benchchem.com or [Request Quote Online](#).

References

- 1. Smooth muscle cell proliferation. Expression and kinase activities of p34cdc2 and mitogen-activated protein kinase homologues - PubMed [pubmed.ncbi.nlm.nih.gov]
- 2. Regulation of p34cdc2 protein kinase during mitosis - PubMed [pubmed.ncbi.nlm.nih.gov]
- 3. Dissociation of p34cdc2 complex formation from phosphorylation and histone H1 kinase activity - PubMed [pubmed.ncbi.nlm.nih.gov]
- 4. scispace.com [scispace.com]
- 5. Cyclin B targets p34cdc2 for tyrosine phosphorylation - PMC [pmc.ncbi.nlm.nih.gov]
- 6. Dephosphorylation and activation of a p34cdc2/cyclin B complex in vitro by human CDC25 protein - PubMed [pubmed.ncbi.nlm.nih.gov]
- 7. embopress.org [embopress.org]
- 8. molbiolcell.org [molbiolcell.org]
- 9. Differential expression and activity of p34cdc2 in cultured aortic adventitial fibroblasts derived from spontaneously hypertensive and Wistar-Kyoto rats - PubMed [pubmed.ncbi.nlm.nih.gov]
- 10. Role of phosphorylation in p34cdc2 activation: identification of an activating kinase - PMC [pmc.ncbi.nlm.nih.gov]
- 11. Characterization of synthetic peptide substrates for p34cdc2 protein kinase - PubMed [pubmed.ncbi.nlm.nih.gov]
- 12. qyaobio.com [qyaobio.com]
- To cite this document: BenchChem. [Application Notes and Protocols for P34cdc2 Kinase Phosphorylation Assays]. BenchChem, [2026]. [Online PDF]. Available at: [<https://www.benchchem.com/product/b12393431/docs#application-notes-and-protocols-for-p34cdc2-kinase-phosphorylation-assays>]

Disclaimer & Data Validity:

The information provided in this document is for Research Use Only (RUO) and is strictly not intended for diagnostic or therapeutic procedures. While BenchChem strives to provide accurate protocols, we make no warranties, express or implied, regarding the fitness of this product for every specific experimental setup.

Technical Support: The protocols provided are for reference purposes. Unsure if this reagent suits your experiment?

Need Industrial/Bulk Grade? [Request Custom Synthesis Quote](#)

BenchChem

Our mission is to be the trusted global source of essential and advanced chemicals, empowering scientists and researchers to drive progress in science and industry.

Contact

Address: 3281 E Guasti Rd
Ontario, CA 91761, United States
Phone: (601) 213-4426
Email: info@benchchem.com

[Contact our Ph.D. Support Team for a compatibility check](#)