

Application Notes and Protocols for Identifying GADGVGKSA-Specific T-Cells

Author: BenchChem Technical Support Team. **Date:** April 2026

Compound of Interest

Compound Name: *Gadgvgksa*

Cat. No.: *B12393105*

[Get Quote](#)

For Researchers, Scientists, and Drug Development Professionals

Introduction

The identification and characterization of T-cells specific for the **GADGVGKSA** neoantigen, derived from the KRAS G12V mutation, are critical for the development of targeted cancer immunotherapies. This document provides detailed application notes and experimental protocols for three primary methods used to detect and quantify these specific T-cells: MHC Multimer Staining, Enzyme-Linked Immunospot (ELISpot) Assay, and Intracellular Cytokine Staining (ICS).

The **GADGVGKSA** peptide is a 9-mer neoantigen resulting from a glycine to valine substitution at codon 12 of the KRAS protein. This mutation is a common driver in several cancers, including pancreatic, colorectal, and non-small cell lung cancers. T-cells capable of recognizing this neoantigen when presented by specific Human Leukocyte Antigen (HLA) molecules, such as HLA-A11:01 and HLA-A03:01, are of significant therapeutic interest.^{[1][2]}

T-Cell Receptor Signaling Pathway

Recognition of the **GADGVGKSA** peptide presented by an MHC molecule on an antigen-presenting cell (APC) by a specific T-cell receptor (TCR) initiates a complex signaling cascade. This cascade ultimately leads to T-cell activation, proliferation, cytokine production, and cytotoxic activity against tumor cells. The key events in this pathway include the phosphorylation of immunoreceptor tyrosine-based activation motifs (ITAMs) within the CD3 complex, recruitment and activation of ZAP-70, and the subsequent activation of downstream pathways such as the PLC γ 1-Ca $^{2+}$ -NFAT, RAS-MAPK, and PKC θ -NF- κ B pathways.[3][4][5]

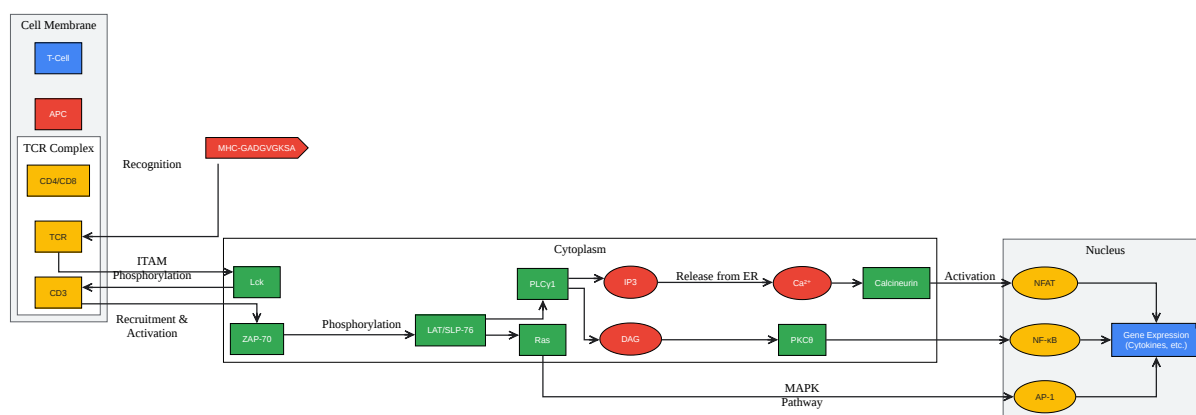

[Click to download full resolution via product page](#)

Caption: T-Cell Receptor (TCR) signaling cascade upon recognition of the **GADGVGKSA** peptide.

Comparison of Methods for Identifying **GADGVGKSA**-Specific T-Cells

The choice of method for identifying **GADGVGKSA**-specific T-cells depends on the specific research question, available resources, and the desired level of detail. The following table summarizes the key characteristics of each technique.

Feature	MHC Multimer Staining	ELISpot Assay	Intracellular Cytokine Staining (ICS)
Principle	Direct visualization of T-cells with specific TCRs using fluorescently labeled peptide-MHC complexes.	Enumeration of cells secreting a specific cytokine upon antigen stimulation.	Detection of intracellular cytokine production in response to antigen stimulation at the single-cell level.
Primary Output	Frequency (%) of antigen-specific T-cells within a population.	Number of spot-forming units (SFU) per million cells.	Percentage (%) of cytokine-producing T-cells and their phenotype.
Sensitivity	High for detecting high-avidity T-cells; may miss low-avidity clones.	Very high; considered one of the most sensitive functional assays.	High, but can be slightly less sensitive than ELISpot for detecting rare cells.
Functionality	Primarily phenotypic; does not directly measure function, but can be combined with functional markers.	Measures cytokine secretion, a key T-cell function.	Measures cytokine production and allows for polyfunctional analysis (multiple cytokines per cell).
Phenotyping	Excellent; allows for simultaneous staining of surface markers (e.g., CD8, CD4, memory markers).	Limited; does not provide phenotypic information about the secreting cells.	Excellent; allows for extensive phenotyping of cytokine-producing cells.
Throughput	Moderate to high.	High; suitable for screening large numbers of samples.	Moderate to high.
Cell Requirement	Moderate.	Low to moderate.	Moderate to high.
Cost	High (reagent-intensive).	Moderate.	High (reagent and instrument-intensive).

Experimental Protocols

MHC Multimer Staining for **GADGVGKSA**-Specific T-Cells

This method allows for the direct identification and enumeration of T-cells that can bind to the **GADGVGKSA** peptide presented by a specific HLA allotype.

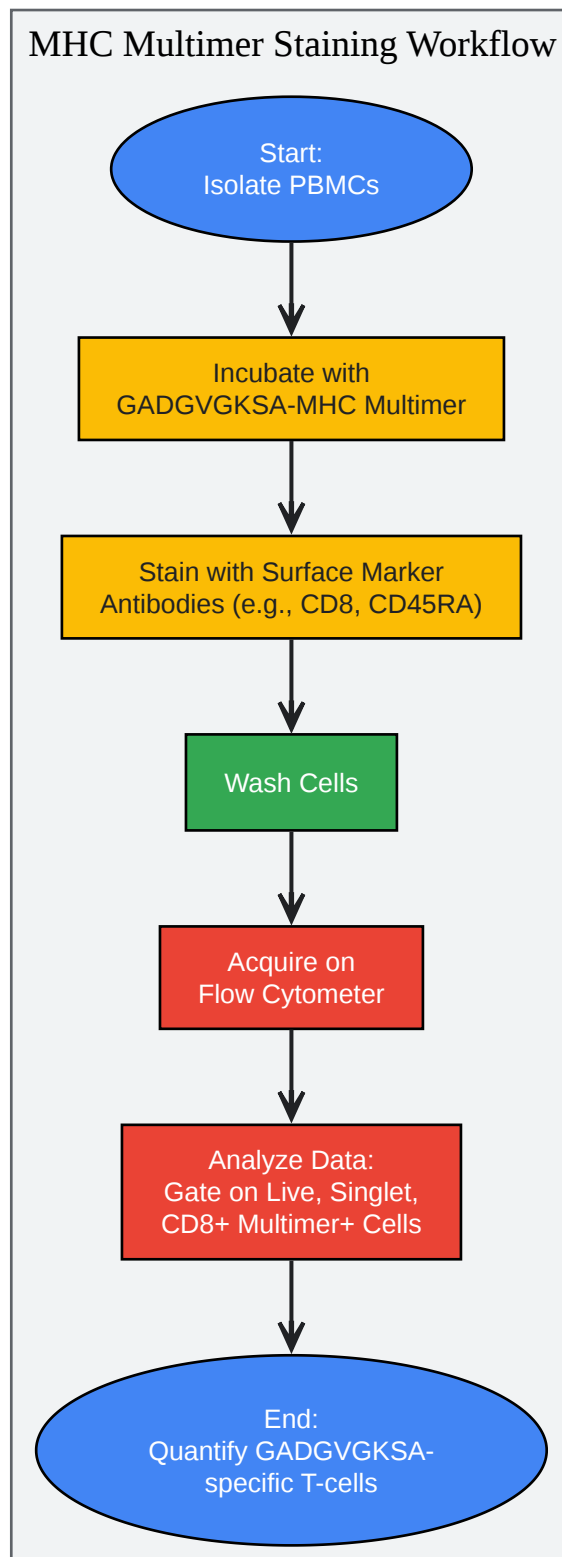

[Click to download full resolution via product page](#)

Caption: Workflow for identifying **GADGVGKSA**-specific T-cells using MHC multimer staining.

Materials:

- Peripheral Blood Mononuclear Cells (PBMCs) from HLA-A11:01 or HLA-A03:01 positive donors
- **GADGVGKSA**-HLA-A11:01 or **GADGVGKSA**-HLA-A03:01 MHC Class I Monomers (biotinylated)
- Streptavidin conjugated to a fluorochrome (e.g., PE, APC)
- Fluorescently conjugated antibodies against T-cell surface markers (e.g., CD3, CD8, CD4, CCR7, CD45RA)
- FACS Buffer (PBS with 2% FBS and 0.1% sodium azide)
- 96-well V-bottom plates or FACS tubes
- Flow cytometer

Protocol:

- Prepare MHC Multimers: Tetramerize biotinylated **GADGVGKSA**-MHC monomers by incubating with fluorescently labeled streptavidin at a 4:1 molar ratio.
- Cell Preparation: Thaw cryopreserved PBMCs and resuspend in FACS buffer at a concentration of $1-2 \times 10^7$ cells/mL.
- Staining: a. Add 50-100 μ L of the cell suspension ($1-2 \times 10^6$ cells) to a 96-well plate or FACS tube. b. Add the **GADGVGKSA**-MHC multimer at the predetermined optimal concentration. c. Incubate for 30-60 minutes at room temperature, protected from light. d. Add a cocktail of fluorescently conjugated antibodies against surface markers. e. Incubate for 20-30 minutes at 4°C in the dark.
- Washing: a. Wash the cells twice with 200 μ L of cold FACS buffer. b. Centrifuge at 300-400 x g for 5 minutes between washes.
- Data Acquisition: a. Resuspend the cells in 200 μ L of FACS buffer. b. Acquire events on a flow cytometer. Collect a sufficient number of events (e.g., at least 100,000 live lymphocyte

events).

- Data Analysis: a. Gate on live, single lymphocytes based on forward and side scatter. b. Gate on CD3+ T-cells. c. Within the CD3+ population, gate on CD8+ T-cells. d. Identify the **GADGVGKSA**-specific T-cell population as the cells positive for the MHC multimer staining within the CD8+ gate. e. Quantify the percentage of multimer-positive cells among the CD8+ T-cells.

ELISpot Assay for **GADGVGKSA**-Specific T-Cells

This assay quantifies the number of T-cells that secrete a specific cytokine (typically IFN- γ) in response to stimulation with the **GADGVGKSA** peptide.

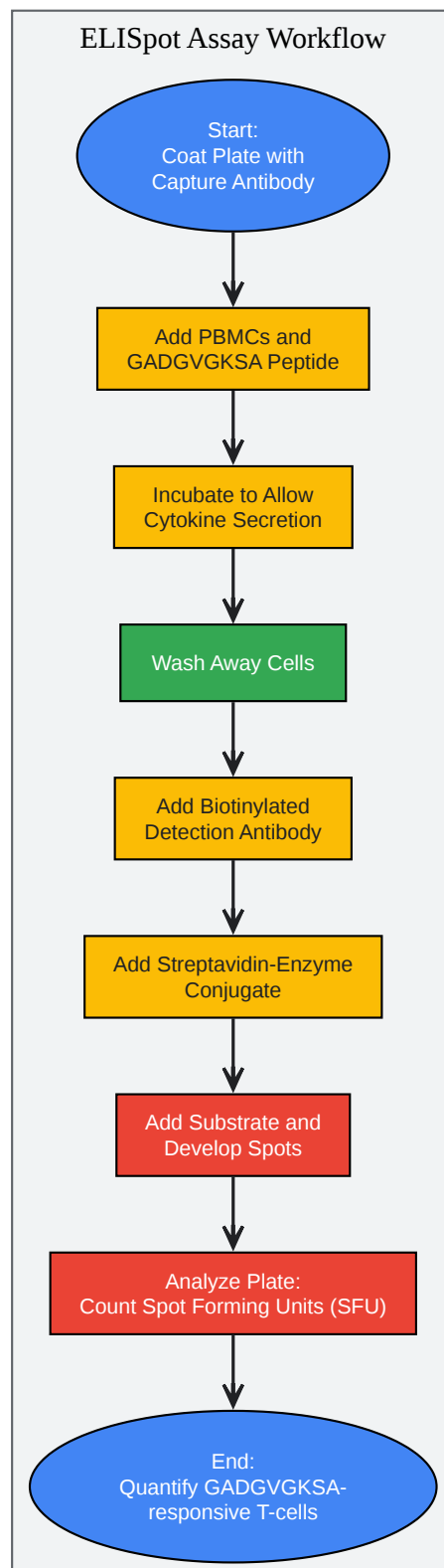

[Click to download full resolution via product page](#)

Caption: Workflow for detecting **GADGVGKSA**-responsive T-cells using an ELISpot assay.

Materials:

- 96-well PVDF membrane ELISpot plates
- Capture antibody (e.g., anti-human IFN- γ)
- Biotinylated detection antibody (e.g., anti-human IFN- γ)
- Streptavidin-alkaline phosphatase (ALP) or horseradish peroxidase (HRP)
- Substrate for ALP (e.g., BCIP/NBT) or HRP (e.g., AEC)
- **GADGVGKSA** peptide
- PBMCs
- Complete RPMI medium
- Wash buffers (PBS and PBS-Tween)

Protocol:

- Plate Coating: a. Coat the ELISpot plate with the capture antibody overnight at 4°C. b. Wash the plate and block with complete RPMI medium.
- Cell Plating and Stimulation: a. Add PBMCs to the wells at a density of $2-5 \times 10^5$ cells/well. b. Add the **GADGVGKSA** peptide to the appropriate wells at a final concentration of 1-10 $\mu\text{g/mL}$. c. Include negative control wells (cells only) and positive control wells (e.g., phytohemagglutinin). d. Incubate the plate for 18-24 hours at 37°C in a 5% CO₂ incubator.
- Detection: a. Wash the plate to remove cells. b. Add the biotinylated detection antibody and incubate for 2 hours at room temperature. c. Wash the plate and add the streptavidin-enzyme conjugate. Incubate for 1 hour at room temperature. d. Wash the plate and add the substrate.
- Spot Development and Analysis: a. Monitor spot development and stop the reaction by washing with distilled water. b. Allow the plate to dry completely. c. Count the spots in each well using an automated ELISpot reader. d. Calculate the number of spot-forming units

(SFU) per million PBMCs by subtracting the background (negative control) from the peptide-stimulated wells.

Intracellular Cytokine Staining (ICS) for **GADGVGKSA**-Specific T-Cells

This method identifies and quantifies T-cells that produce specific cytokines intracellularly upon stimulation with the **GADGVGKSA** peptide. It also allows for the simultaneous phenotyping of the responding cells.

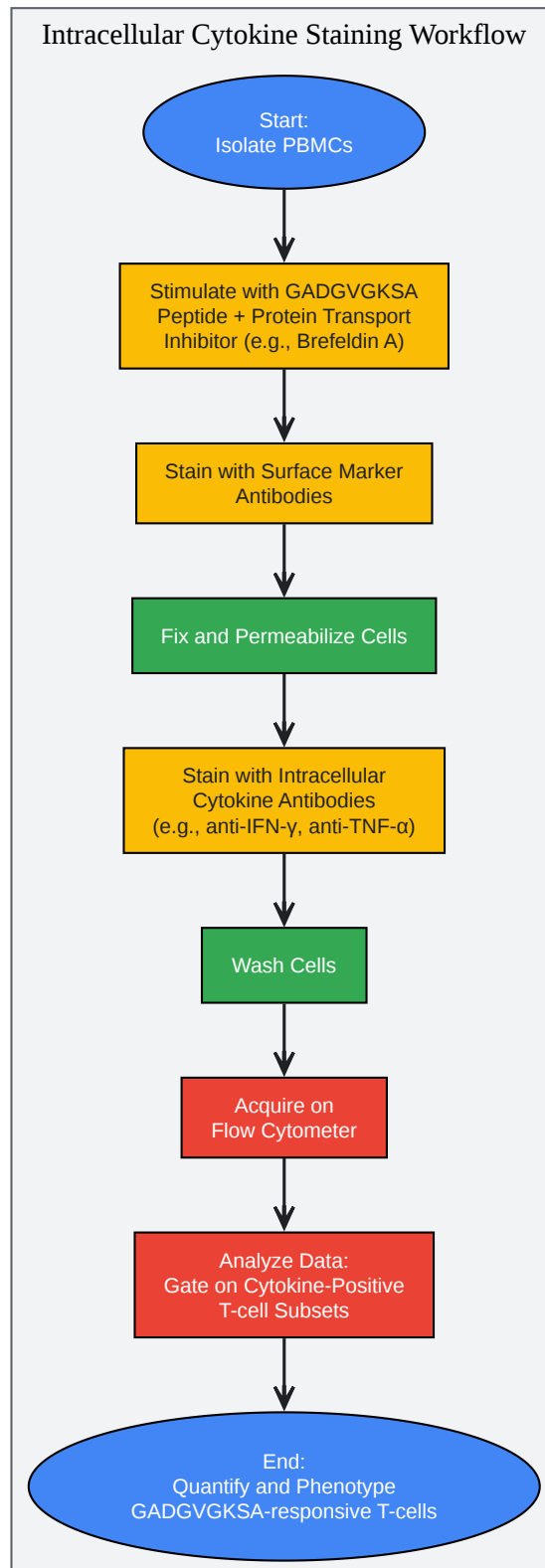

[Click to download full resolution via product page](#)

Caption: Workflow for detecting and phenotyping **GADGVGKSA**-responsive T-cells via intracellular cytokine staining.

Materials:

- PBMCs
- **GADGVGKSA** peptide
- Protein transport inhibitor (e.g., Brefeldin A or Monensin)
- Fluorescently conjugated antibodies against surface markers (e.g., CD3, CD8, CD4)
- Fixation/Permeabilization buffer kit
- Fluorescently conjugated antibodies against intracellular cytokines (e.g., IFN- γ , TNF- α , IL-2)
- FACS Buffer
- 96-well U-bottom plates or FACS tubes
- Flow cytometer

Protocol:

- Cell Stimulation: a. Resuspend PBMCs in complete RPMI medium at $1-2 \times 10^6$ cells/mL. b. Add the **GADGVGKSA** peptide (1-10 $\mu\text{g/mL}$) and a protein transport inhibitor. c. Incubate for 4-6 hours at 37°C in a 5% CO₂ incubator.
- Surface Staining: a. Wash the cells with FACS buffer. b. Stain with antibodies against surface markers for 20-30 minutes at 4°C.
- Fixation and Permeabilization: a. Wash the cells. b. Resuspend in fixation buffer and incubate for 20 minutes at room temperature. c. Wash and resuspend in permeabilization buffer.
- Intracellular Staining: a. Add antibodies against intracellular cytokines. b. Incubate for 30 minutes at room temperature in the dark.

- Washing and Acquisition: a. Wash the cells with permeabilization buffer, followed by a final wash with FACS buffer. b. Resuspend in FACS buffer and acquire on a flow cytometer.
- Data Analysis: a. Gate on live, single lymphocytes. b. Gate on CD3+ T-cells, and then on CD8+ and CD4+ subsets. c. Within each subset, quantify the percentage of cells expressing the cytokine(s) of interest.

Data Presentation

Quantitative data from these assays should be presented in a clear and structured format to allow for easy comparison.

Table 1: Representative Data for **GADGVGKSA**-Specific T-Cell Frequencies

Method	Parameter Measured	Typical Frequency in Positive Samples
MHC Multimer Staining	% of GADGVGKSA-MHC Multimer+ cells in CD8+ T-cells	0.1% - 2.0%
ELISpot Assay	Spot Forming Units (SFU) per 10 ⁶ PBMCs	50 - 500
Intracellular Cytokine Staining	% of IFN-γ+ cells in CD8+ T-cells	0.1% - 1.5%

Note: These values are illustrative and can vary significantly based on the patient's immune status, tumor burden, and the specific assay conditions.

Conclusion

The methods described provide a comprehensive toolkit for the identification and characterization of **GADGVGKSA**-specific T-cells. The choice of assay should be guided by the specific experimental goals. MHC multimer staining offers direct enumeration and phenotyping, ELISpot provides a highly sensitive measure of cytokine-secreting cell frequency, and ICS allows for detailed functional and phenotypic analysis at the single-cell level. Rigorous adherence to these protocols will ensure the generation of reliable and reproducible data,

which is essential for advancing the development of novel immunotherapies targeting KRAS G12V-mutant cancers.

Need Custom Synthesis?

BenchChem offers custom synthesis for rare earth carbides and specific isotopic labeling.

Email: info@benchchem.com or [Request Quote Online](#).

References

- 1. [Frontiers | Targeting KRASG12V mutations with HLA class II-restricted TCR for the immunotherapy in solid tumors \[frontiersin.org\]](#)
- 2. [Phase I study of autologous CD8+ and CD4+ transgenic T cells expressing high-affinity KRAS G12V mutation-specific T cell receptors \(FH-A11KRASG12V-TCR\) in patients with metastatic pancreatic, colorectal, and non-small cell lung cancers with KRAS G12V mutations. - ASCO \[asco.org\]](#)
- 3. [creative-diagnostics.com \[creative-diagnostics.com\]](#)
- 4. [researchgate.net \[researchgate.net\]](#)
- 5. [T Cell Receptor Signaling | Cell Signaling Technology \[cellsignal.com\]](#)
- To cite this document: BenchChem. [Application Notes and Protocols for Identifying GADGVGKSA-Specific T-Cells]. BenchChem, [2026]. [Online PDF]. Available at: [\[https://www.benchchem.com/product/b12393105/docs#application-notes-and-protocols-for-identifying-gadvgksa-specific-t-cells\]](https://www.benchchem.com/product/b12393105/docs#application-notes-and-protocols-for-identifying-gadvgksa-specific-t-cells)

Disclaimer & Data Validity:

The information provided in this document is for Research Use Only (RUO) and is strictly not intended for diagnostic or therapeutic procedures. While BenchChem strives to provide accurate protocols, we make no warranties, express or implied, regarding the fitness of this product for every specific experimental setup.

Technical Support: The protocols provided are for reference purposes. Unsure if this reagent suits your experiment?

Need Industrial/Bulk Grade? [Request Custom Synthesis Quote](#)

BenchChem

Our mission is to be the trusted global source of essential and advanced chemicals, empowering scientists and researchers to drive progress in science and industry.

Contact

Address: 3281 E Guasti Rd

Ontario, CA 91761, United States

Phone: (601) 213-4426

Email: info@benchchem.com

[Contact our Ph.D. Support Team for a compatibility check](#)