

Application Note: Structural Analysis of Leuprolide Acetate EP Impurity D using NMR Spectroscopy

Author: BenchChem Technical Support Team. **Date:** April 2026

Compound of Interest

Compound Name: *Leuprolide Acetate EP Impurity D*

Cat. No.: *B12393413*

[Get Quote](#)

For Researchers, Scientists, and Drug Development Professionals

Abstract

This application note details the use of Nuclear Magnetic Resonance (NMR) spectroscopy for the comprehensive structural analysis and characterization of **Leuprolide Acetate EP Impurity D**. Leuprolide, a synthetic nonapeptide analog of gonadotropin-releasing hormone (GnRH), and its impurities require rigorous structural elucidation to ensure the safety and efficacy of the final drug product.[1] EP Impurity D is identified as (O-ACETYL-L-SER)-LEUPROLIDE, with the amino acid sequence H-Pyr-His-Trp-Ser(Ac)-Tyr-D-Leu-Leu-Arg-Pro-NHEt.[2] This document provides detailed protocols for one-dimensional (1D) and two-dimensional (2D) NMR experiments, including ^1H , ^{13}C , COSY, TOCSY, HSQC, and HMBC, which are instrumental in confirming the peptide's primary structure and the presence of the O-acetyl group on the serine residue. The presented methodologies and data serve as a guide for researchers in the pharmaceutical industry for the structural characterization of peptide impurities.

Introduction

Leuprolide Acetate is a cornerstone in the treatment of various hormone-responsive cancers and other conditions.[1] The manufacturing process of synthetic peptides can often lead to the formation of impurities, which must be identified and quantified to meet regulatory standards.

Leuprolide Acetate EP Impurity D is a relevant process-related impurity distinguished by the O-acetylation of the serine residue at position four.

NMR spectroscopy is a powerful, non-destructive analytical technique that provides detailed atomic-level structural information, making it ideal for the unambiguous identification of peptide impurities.[3][4] This note outlines a systematic approach using a suite of NMR experiments to confirm the identity and structure of **Leuprolide Acetate EP Impurity D**.

Experimental Protocols

Sample Preparation

Proper sample preparation is critical for acquiring high-quality NMR data.[5]

- **Sample Weighing:** Accurately weigh 5-10 mg of **Leuprolide Acetate EP Impurity D** reference standard.
- **Solvent Selection:** Dissolve the sample in 500 μL of a deuterated solvent system. A common choice for peptides is a mixture of 90% H_2O / 10% D_2O to allow for the observation of exchangeable amide protons, or 100% DMSO-d_6 for improved solubility and reduced signal overlap.[6] The choice of solvent can influence chemical shifts.[7]
- **pH Adjustment:** Adjust the pH of the aqueous sample to a value between 4 and 5 to slow down the exchange rate of amide protons with the solvent.
- **Internal Standard:** For quantitative NMR (qNMR), a certified internal standard with a known concentration and non-overlapping signals, such as maleic acid or DSS, should be added.[8][9]
- **Transfer to NMR Tube:** Transfer the final solution to a high-precision 5 mm NMR tube.

NMR Data Acquisition

All spectra should be acquired on a high-field NMR spectrometer (e.g., 500 MHz or higher) equipped with a cryoprobe for enhanced sensitivity.[10]

- ^1H NMR: A standard one-dimensional proton spectrum is acquired to obtain an overview of the sample's proton environment.
- ^{13}C NMR: A one-dimensional carbon spectrum, often acquired using proton decoupling, provides information on the carbon framework.
- 2D COSY (Correlation Spectroscopy): This experiment identifies protons that are coupled to each other, typically through two or three bonds, which is crucial for identifying adjacent protons within an amino acid spin system.[\[11\]](#)[\[12\]](#)[\[13\]](#)
- 2D TOCSY (Total Correlation Spectroscopy): TOCSY establishes correlations between all protons within a spin system, from the amide proton to the sidechain protons of an amino acid residue.[\[6\]](#)[\[12\]](#)
- 2D HSQC (Heteronuclear Single Quantum Coherence): This experiment correlates protons directly attached to heteronuclei, primarily ^{13}C or ^{15}N , providing direct one-bond C-H or N-H correlations.[\[11\]](#)[\[12\]](#)[\[13\]](#)
- 2D HMBC (Heteronuclear Multiple Bond Correlation): HMBC reveals long-range correlations (typically 2-4 bonds) between protons and carbons, which is essential for sequencing amino acids and identifying modifications like the O-acetyl group.[\[12\]](#)[\[13\]](#)

Data Presentation: Predicted Chemical Shifts

The following table summarizes the predicted ^1H and ^{13}C chemical shifts for **Leuprolide Acetate EP Impurity D** based on standard amino acid values in a peptide environment and the influence of the O-acetyl group on Serine. Actual experimental values may vary depending on solvent, temperature, and pH.

| Amino Acid Residue | Atom | Predicted ¹ H Chemical Shift (ppm) | Predicted ¹³ C Chemical Shift (ppm) |
|--------------------|------------------------|---|--|
| Pyr | α-CH | 4.25 | 57.5 |
| | β-CH ₂ | 2.10, 2.45 | 29.8 |
| | γ-CH ₂ | 2.30 | 25.5 |
| | δ-C=O | - | 178.0 |
| His | α-CH | 4.70 | 54.0 |
| | β-CH ₂ | 3.15 | 28.5 |
| | δ-CH | 7.80 | 135.0 |
| | ε-CH | 7.10 | 118.0 |
| Trp | α-CH | 4.65 | 55.5 |
| | β-CH ₂ | 3.30 | 27.8 |
| | Indole C2-H | 7.20 | 124.0 |
| | Indole C4-H | 7.60 | 118.5 |
| | Indole C5-H | 7.15 | 119.5 |
| | Indole C6-H | 7.05 | 121.5 |
| | Indole C7-H | 7.50 | 111.5 |
| Ser(Ac) | α-CH | 4.50 | 56.0 |
| | β-CH ₂ | 4.30, 4.45 | 64.0 |
| | Acetyl CH ₃ | 2.05 | 21.0 |
| Acetyl C=O | - | 171.0 | |
| Tyr | α-CH | 4.60 | 56.5 |
| | β-CH ₂ | 3.05 | 37.0 |
| | Phenyl C2,6-H | 7.10 | 130.5 |

| | | | |
|---------------------------|-----------------|------------|------|
| Phenyl C3,5-H | 6.75 | 115.5 | |
| D-Leu | α -CH | 4.40 | 53.5 |
| β -CH ₂ | 1.65 | 40.5 | |
| γ -CH | 1.50 | 25.0 | |
| δ -CH ₃ | 0.90, 0.95 | 22.5, 23.0 | |
| Leu | α -CH | 4.35 | 53.0 |
| β -CH ₂ | 1.70 | 40.0 | |
| γ -CH | 1.55 | 24.8 | |
| δ -CH ₃ | 0.92, 0.97 | 22.0, 23.5 | |
| Arg | α -CH | 4.30 | 54.5 |
| β -CH ₂ | 1.85 | 29.0 | |
| γ -CH ₂ | 1.60 | 25.0 | |
| δ -CH ₂ | 3.20 | 41.0 | |
| Guanido C | - | 157.0 | |
| Pro | α -CH | 4.45 | 61.0 |
| β -CH ₂ | 2.00, 2.30 | 30.0 | |
| γ -CH ₂ | 1.90 | 25.5 | |
| δ -CH ₂ | 3.65 | 47.5 | |
| NHEt | CH ₂ | 3.25 | 34.5 |
| CH ₃ | 1.10 | 15.0 | |

Structural Elucidation Workflow and Visualization

The structural confirmation of **Leuprolide Acetate EP Impurity D** follows a logical workflow, beginning with 1D NMR for a general assessment, followed by 2D NMR experiments for detailed residue identification and sequential assignment.

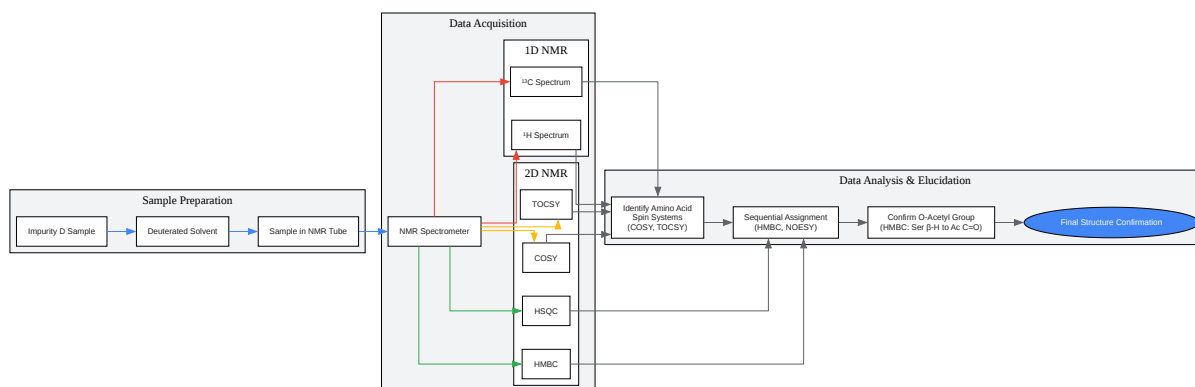

[Click to download full resolution via product page](#)

Caption: Workflow for the structural elucidation of **Leuprolide Acetate EP Impurity D** by NMR.

Key Structural Confirmation Steps

- **Amino Acid Identification:** Using COSY and TOCSY spectra, the individual spin systems for each amino acid residue are identified. For example, the characteristic spin system of Leucine (α - β - γ - δ) can be traced from its amide proton.

- **Sequential Assignment:** HMBC is critical for linking adjacent amino acid residues. A key correlation would be observed between the α -proton of one residue and the carbonyl carbon of the preceding residue.
- **Confirmation of Ser(Ac) Modification:** The presence and location of the O-acetyl group are unequivocally confirmed by a crucial HMBC correlation. A cross-peak between the β -protons of the Serine residue (shifted downfield due to acetylation) and the carbonyl carbon of the acetyl group provides definitive evidence of the O-acetylation at the Serine sidechain. Additional confirmation comes from the strong singlet in the ^1H spectrum around 2.05 ppm corresponding to the acetyl methyl protons.

Conclusion

NMR spectroscopy provides an unparalleled level of detail for the structural analysis of peptide impurities like **Leuprolide Acetate EP Impurity D**. Through a combination of 1D and 2D NMR experiments, it is possible to unambiguously confirm the amino acid sequence, stereochemistry, and the specific site of modification. The protocols and expected data presented in this application note serve as a comprehensive guide for the structural characterization of modified peptide impurities, ensuring the quality and safety of pharmaceutical products.

Need Custom Synthesis?

BenchChem offers custom synthesis for rare earth carbides and specific isotopic labeling.

Email: info@benchchem.com or [Request Quote Online](#).

References

1. go.drugbank.com [go.drugbank.com]
2. [Leuprolide Acetate EP Impurity D | C61H86N16O13 | CID 145707671 - PubChem](#) [pubchem.ncbi.nlm.nih.gov]
3. [NMR Spectroscopy in the Conformational Analysis of Peptides: An Overview - PubMed](#) [pubmed.ncbi.nlm.nih.gov]
4. [NMR Spectroscopy of Peptides and Proteins | Springer Nature Experiments](#) [experiments.springernature.com]

- [5. NMR-Based Peptide Structure Analysis - Creative Proteomics \[creative-proteomics.com\]](#)
- [6. chem.uzh.ch \[chem.uzh.ch\]](#)
- [7. emerypharma.com \[emerypharma.com\]](#)
- [8. Quantitative NMR \(qNMR\) | Nuclear Magnetic Resonance \(NMR\) | \[Analytical Chemistry\] | Laboratory Chemicals-FUJIFILM Wako Chemicals Europe GmbH \[labchem-wako.fujifilm.com\]](#)
- [9. jeolusa.s3.amazonaws.com \[jeolusa.s3.amazonaws.com\]](#)
- [10. Protein & Peptide NMR Spectroscopy : Practical Aspects \[saromics.com\]](#)
- [11. Two-dimensional nuclear magnetic resonance spectroscopy - Wikipedia \[en.wikipedia.org\]](#)
- [12. princeton.edu \[princeton.edu\]](#)
- [13. 7\) Common 2D \(COSY, HSQC, HMBC\) | SDSU NMR Facility – Department of Chemistry \[nmr.sdsu.edu\]](#)
- To cite this document: BenchChem. [Application Note: Structural Analysis of Leuprolide Acetate EP Impurity D using NMR Spectroscopy]. BenchChem, [2026]. [Online PDF]. Available at: [<https://www.benchchem.com/product/b12393413/docs#application-note-structural-analysis-of-leuprolide-acetate-ep-impurity-d-using-nmr-spectroscopy>]

Disclaimer & Data Validity:

The information provided in this document is for Research Use Only (RUO) and is strictly not intended for diagnostic or therapeutic procedures. While BenchChem strives to provide accurate protocols, we make no warranties, express or implied, regarding the fitness of this product for every specific experimental setup.

Technical Support: The protocols provided are for reference purposes. Unsure if this reagent suits your experiment?

Need Industrial/Bulk Grade? [Request Custom Synthesis Quote](#)

BenchChem

Our mission is to be the trusted global source of essential and advanced chemicals, empowering scientists and researchers to drive progress in science and industry.

Contact

Address: 3281 E Guasti Rd

Ontario, CA 91761, United States

Phone: (601) 213-4426

Email: info@benchchem.com

[Contact our Ph.D. Support Team for a compatibility check](#)