

A Comparative Analysis of Key-Value Stores for Research Data

Author: BenchChem Technical Support Team. **Date:** April 2026

Compound of Interest

Compound Name: NDBM
Cat. No.: B12393030

[Get Quote](#)

In the rapidly evolving landscape of scientific research and drug development, the efficient management and retrieval of vast datasets are paramount. Key-value stores, a type of NoSQL database, have emerged as a powerful solution for handling the large, unstructured, and semi-structured data prevalent in these fields. Their simple data model, high performance, and scalability make them well-suited for a variety of research applications, from storing genomic metadata to managing high-throughput screening results. This guide provides an objective comparison of popular key-value stores, supported by experimental data, to assist researchers, scientists, and drug development professionals in selecting the optimal solution for their specific needs.

Key-Value Stores: A Primer

A key-value store is a simple database that stores data as a collection of key-value pairs. Each key is a unique identifier, and the associated value can be any type of data, from a simple string to a complex object. This schema-less nature offers significant flexibility, a crucial feature when dealing with the diverse and evolving data formats in scientific research.[\[1\]](#)[\[2\]](#)[\[3\]](#)

Use Cases in Research and Drug Development:

- Genomic and Proteomic Data: Storing and retrieving metadata associated with large sequencing datasets.[\[4\]](#)[\[5\]](#)[\[6\]](#)
- Drug Discovery: Caching molecular structures, managing high-throughput screening data, and storing results from computational models.[\[7\]](#)[\[8\]](#)[\[9\]](#)
- Real-Time Analytics: Powering interactive dashboards for analyzing experimental data.[\[2\]](#)[\[10\]](#)
- Metadata Management: Efficiently handling metadata for large-scale scientific simulations and experiments.[\[11\]](#)[\[12\]](#)

Performance Comparison of Key-Value Stores

The selection of a key-value store often hinges on its performance characteristics. The following tables summarize the performance of several popular key-value stores based on common benchmarking workloads. The primary metrics considered are throughput (operations per second) and latency (the time to complete a single operation).[\[13\]](#)

In-Memory Key-Value Stores

In-memory databases store data primarily in the main memory (RAM), leading to extremely low latency and high throughput, making them ideal for caching and real-time applications.

Key-Value Store	Read Throughput (ops/sec)	Write Throughput (ops/sec)	Average Latency (ms)	Data Persistence	Strengths
Redis	High	High	Very Low (<1)	Yes (Snapshots, AOF)	Rich data structures, high flexibility, strong community support. [14]
Memcached	Very High	High	Very Low (<1)	No	Simplicity, low overhead, excellent for pure caching. [10]

On-Disk Key-Value Stores

On-disk databases persist data to disk, allowing for datasets much larger than the available RAM and ensuring data durability.

Key-Value Store	Read Throughput (ops/sec)	Write Throughput (ops/sec)	Data Durability	Strengths
RocksDB	High	Very High	High	Optimized for fast storage (SSDs), high write throughput, tunable.[14][15]
LevelDB	Moderate	Moderate	High	Simple, lightweight, good for read-heavy workloads.[15]
BadgerDB	High	High	High	Optimized for SSDs, lower write amplification than RocksDB. [16]

Experimental Protocols

To ensure objective and reproducible performance comparisons, standardized benchmarking methodologies are crucial. The Yahoo! Cloud Serving Benchmark (YCSB) is a widely adopted framework for evaluating the performance of NoSQL databases, including key-value stores.[13][17][18]

A typical YCSB benchmarking process involves two main phases:

- **Data Loading:** The database is populated with a large, synthetic dataset of a specified size.
- **Workload Execution:** A series of operations (reads, writes, updates, scans) are performed against the loaded data, simulating a specific application workload.

The following diagram illustrates a standard experimental workflow for benchmarking key-value stores using YCSB.

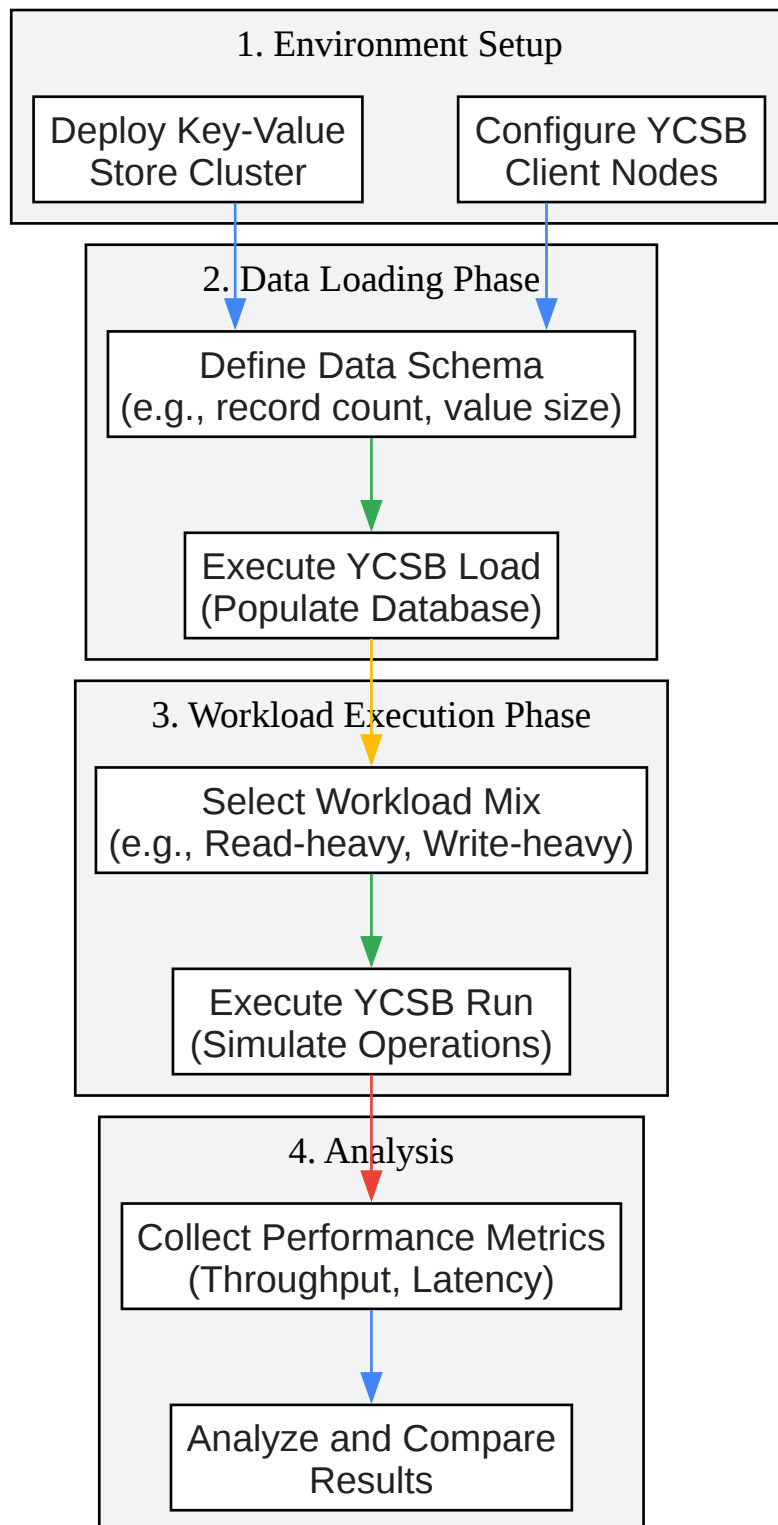

[Click to download full resolution via product page](#)

A typical workflow for benchmarking key-value stores.

YCSB Standard Workloads

YCSB defines a set of standard workloads to simulate different application patterns, which can be adapted to represent research data access scenarios:

- Workload A (Update Heavy): 50% reads, 50% updates. Simulates scenarios with frequent updates to existing data, such as updating metadata for genomic samples.
- Workload B (Read Mostly): 95% reads, 5% updates. Represents applications where data is frequently read but infrequently modified, like querying a database of chemical compounds. [\[19\]](#)
- Workload C (Read Only): 100% reads. Ideal for benchmarking applications that serve static data, such as a repository of published experimental results.
- Workload D (Read Latest): 95% reads, 5% inserts. Models applications where the most recently inserted data is most frequently accessed, for instance, real-time monitoring of experimental data streams.
- Workload E (Short Ranges): 95% scans, 5% inserts. Simulates applications that perform short range queries, such as retrieving a specific range of genomic markers.
- Workload F (Read-Modify-Write): 50% reads, 50% read-modify-writes. Represents scenarios where a record is read, modified, and then written back, which can occur during the annotation of biological data. [\[19\]](#)

Data Modeling in Key-Value Stores for Research

The simplicity of the key-value model requires careful consideration of the key design to efficiently query and retrieve data. For research data, a common strategy is to create composite keys that encode hierarchical or relational information.

For example, in a drug discovery context, you might store data about the interaction between a compound and a target protein. A well-designed key could be `compound:{compound_id}:target:{target_id}`, with the value being a JSON object containing details of the interaction.

The following diagram illustrates the logical relationship of how different research data entities can be modeled and linked within a key-value store.

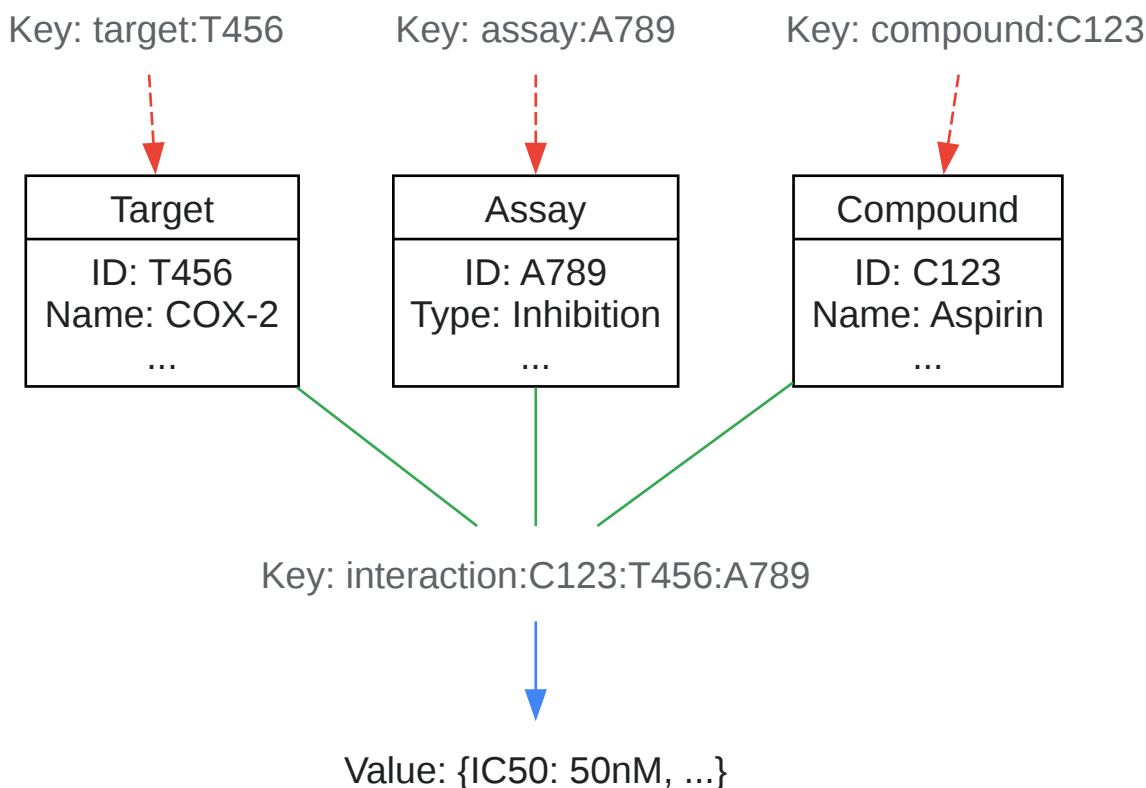

[Click to download full resolution via product page](#)

Modeling drug discovery data in a key-value store.

Conclusion

Key-value stores offer a compelling solution for managing the diverse and large-scale data generated in scientific research and drug development. In-memory stores like Redis and Memcached provide exceptional performance for caching and real-time analysis, while on-disk stores such as RocksDB and BadgerDB are well-suited for durable storage of large datasets with high write throughput.

The choice of a specific key-value store should be guided by the specific requirements of the application, including data size, read/write patterns, and latency requirements. By leveraging standardized benchmarking tools like YCSB and thoughtful data modeling, researchers can

make informed decisions to build robust and high-performance data management systems that accelerate scientific discovery.

Need Custom Synthesis?

BenchChem offers custom synthesis for rare earth carbides and specific isotopic labeling.

Email: info@benchchem.com or [Request Quote Online](#).

References

- [1. mdpi.com \[mdpi.com\]](#)
- [2. Unlocking Efficiency and Speed: Exploring Key-Value Store Databases | by Make Computer Science Great Again | Medium \[medium.com\]](#)
- [3. hazelcast.com \[hazelcast.com\]](#)
- [4. Database Performance for Genomic Data at Scale \[wadeschulz.com\]](#)
- [5. academic.oup.com \[academic.oup.com\]](#)
- [6. horizon.documentation.ird.fr \[horizon.documentation.ird.fr\]](#)
- [7. Strategies for robust, accurate, and generalizable benchmarking of drug discovery platforms - PMC \[pmc.ncbi.nlm.nih.gov\]](#)
- [8. pubs.acs.org \[pubs.acs.org\]](#)
- [9. drugpatentwatch.com \[drugpatentwatch.com\]](#)
- [10. medium.com \[medium.com\]](#)
- [11. MetaKV: A Key-Value Store for Metadata Management of Distributed Burst Buffers | IEEE Conference Publication | IEEE Xplore \[ieeexplore.ieee.org\]](#)
- [12. vldb.org \[vldb.org\]](#)
- [13. What is the YCSB benchmark for NoSQL databases? \[milvus.io\]](#)
- [14. stackshare.io \[stackshare.io\]](#)
- [15. m.youtube.com \[m.youtube.com\]](#)
- [16. discuss.dgraph.io \[discuss.dgraph.io\]](#)
- [17. scylladb.com \[scylladb.com\]](#)
- [18. Yahoo! Cloud Serving Benchmark Guide \[benchant.com\]](#)

- [19. Benchmark of RonDB, the fastest Key-Value Store on the cloud. \[rondb.com\]](#)
- To cite this document: BenchChem. [A Comparative Analysis of Key-Value Stores for Research Data]. BenchChem, [2026]. [Online PDF]. Available at: [\[https://www.benchchem.com/product/b12393030/docs#a-comparative-analysis-of-key-value-stores-for-research-data\]](https://www.benchchem.com/product/b12393030/docs#a-comparative-analysis-of-key-value-stores-for-research-data)

Disclaimer & Data Validity:

The information provided in this document is for Research Use Only (RUO) and is strictly not intended for diagnostic or therapeutic procedures. While BenchChem strives to provide accurate protocols, we make no warranties, express or implied, regarding the fitness of this product for every specific experimental setup.

Technical Support: The protocols provided are for reference purposes. Unsure if this reagent suits your experiment?

Need Industrial/Bulk Grade? [Request Custom Synthesis Quote](#)

BenchChem

Our mission is to be the trusted global source of essential and advanced chemicals, empowering scientists and researchers to drive progress in science and industry.

Contact

Address: 3281 E Guasti Rd
Ontario, CA 91761, United States
Phone: (601) 213-4426
Email: info@benchchem.com

[Contact our Ph.D. Support Team for a compatibility check](#)