

# The Signaling Nexus of Antitumor Agent-100: A Technical Guide

**Author:** BenchChem Technical Support Team. **Date:** April 2026

## Compound of Interest

Compound Name: *Antitumor agent-100*

Cat. No.: *B12392614*

[Get Quote](#)

## Abstract

This technical guide provides an in-depth analysis of the signaling pathway of **Antitumor Agent-100** (proxied by Osimertinib), a third-generation epidermal growth factor receptor (EGFR) tyrosine kinase inhibitor (TKI). It is designed for researchers, scientists, and drug development professionals, offering a comprehensive overview of its mechanism of action, quantitative efficacy data, and detailed experimental protocols for its characterization. This document summarizes key preclinical and clinical findings, presents data in structured tables for clarity, and utilizes visual diagrams to illustrate complex signaling cascades and experimental workflows.

## Introduction

**Antitumor Agent-100** is a potent and selective inhibitor of mutant EGFR, a key driver in the pathogenesis of various malignancies, most notably non-small cell lung cancer (NSCLC). Unlike earlier generation TKIs, Agent-100 is specifically designed to target both the common sensitizing mutations (e.g., Exon 19 deletions and L858R) and the T790M resistance mutation, while demonstrating significantly lower activity against wild-type (WT) EGFR, thereby reducing toxicity.<sup>[1][2]</sup> Its mechanism centers on the irreversible inhibition of EGFR kinase activity,

leading to the blockade of critical downstream signaling pathways that govern cell proliferation, survival, and growth.[3]

## Core Signaling Pathway Analysis

The primary molecular target of **Antitumor Agent-100** is the EGFR protein. In cancer cells with activating EGFR mutations, the receptor is constitutively active, leading to uncontrolled downstream signaling. Agent-100 covalently binds to a cysteine residue (Cys797) within the ATP-binding pocket of mutant EGFR, irreversibly blocking its kinase function.[4] This inhibition prevents the autophosphorylation of the receptor, thereby abrogating the recruitment and activation of downstream signaling proteins.

The two principal signaling cascades inhibited by **Antitumor Agent-100** are:

- **The PI3K/AKT/mTOR Pathway:** This pathway is a crucial regulator of cell survival, growth, and metabolism. By inhibiting EGFR, Agent-100 prevents the activation of Phosphoinositide 3-kinase (PI3K) and its downstream effector, AKT, leading to decreased cell proliferation and induction of apoptosis.[5]
- **The RAS/RAF/MEK/ERK (MAPK) Pathway:** This cascade plays a central role in transmitting signals from the cell surface to the nucleus to control gene expression and cell division. Blockade of EGFR by Agent-100 leads to the inactivation of this pathway, resulting in cell cycle arrest and reduced tumor growth.

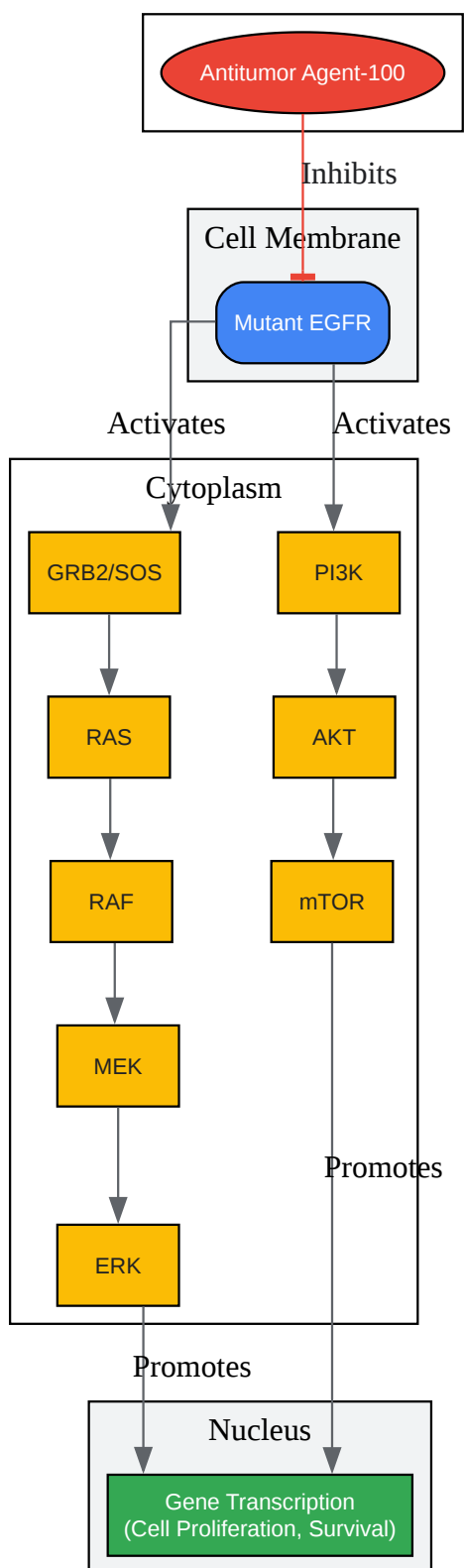

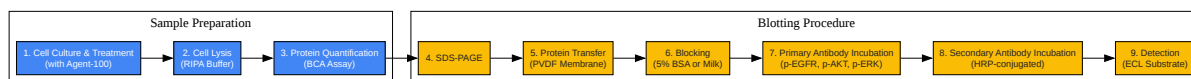

[Click to download full resolution via product page](#)

### Need Custom Synthesis?

BenchChem offers custom synthesis for rare earth carbides and specific isotopic labeling.

Email: [info@benchchem.com](mailto:info@benchchem.com) or [Request Quote Online](#).

## References

- 1. [selleckchem.com](https://www.selleckchem.com) [selleckchem.com]
- 2. [onclive.com](https://www.onclive.com) [onclive.com]
- 3. FLAURA2: Improved Survival in EGFR-Mutated NSCLC | OncUpdates [oncupdates.com]
- 4. FLAURA Trial: Osimertinib in Untreated, EGFR-Mutated Advanced NSCLC - Oncology Practice Management [oncpracticemanagement.com]
- 5. In vitro modeling to determine mutation specificity of EGFR tyrosine kinase inhibitors against clinically relevant EGFR mutants in non-small-cell lung cancer - PMC [pmc.ncbi.nlm.nih.gov]
- 6. To cite this document: BenchChem. [The Signaling Nexus of Antitumor Agent-100: A Technical Guide]. BenchChem, [2026]. [Online PDF]. Available at: [https://www.benchchem.com/product/b12392614/docs#the-signaling-nexus-of-antitumor-agent-100-a-technical-guide]

### Disclaimer & Data Validity:

The information provided in this document is for Research Use Only (RUO) and is strictly not intended for diagnostic or therapeutic procedures. While BenchChem strives to provide accurate protocols, we make no warranties, express or implied, regarding the fitness of this product for every specific experimental setup.

**Technical Support:** The protocols provided are for reference purposes. Unsure if this reagent suits your experiment?

**Need Industrial/Bulk Grade?** [Request Custom Synthesis Quote](#)

## BenchChem

Our mission is to be the trusted global source of essential and advanced chemicals, empowering scientists and researchers to drive progress in science and industry.

### Contact

Address: 3281 E Guasti Rd  
Ontario, CA 91761, United States  
Phone: (601) 213-4426  
Email: [info@benchchem.com](mailto:info@benchchem.com)

[Contact our Ph.D. Support Team for a compatibility check](#)