

The Role of CEP120 in Cell Cycle Progression: A Technical Guide

Author: BenchChem Technical Support Team. **Date:** April 2026

Compound of Interest

Compound Name: CEP120 Human Pre-designed
siRNA Set A

Cat. No.: B12391809

[Get Quote](#)

Executive Summary

Centrosomal Protein 120kDa (CEP120) is a critical regulator of centriole biogenesis, a process intrinsically linked to cell cycle progression. This technical guide provides an in-depth analysis of CEP120's multifaceted role, focusing on its impact on centriole duplication, pericentriolar material (PCM) regulation, and its interplay with key cell cycle signaling pathways. While traditionally known for its essential function in centriole assembly and elongation during S-phase, emerging evidence also points to a crucial inhibitory role in quiescent cells, preventing premature centriole maturation. Dysregulation of CEP120 function is associated with ciliopathies and has been implicated in tumorigenesis, highlighting its importance in maintaining cellular homeostasis. This document synthesizes current quantitative data, details relevant experimental protocols, and visualizes the known signaling and experimental workflows to provide a comprehensive resource for professionals in the field.

Introduction

The centrosome, the primary microtubule-organizing center in animal cells, consists of a pair of centrioles embedded in a protein-rich matrix known as the pericentriolar material (PCM). The

duplication of centrosomes is tightly coordinated with the cell cycle, ensuring that a bipolar spindle is formed during mitosis for accurate chromosome segregation. CEP120 has been identified as a key player in this process. It is a 120 kDa centrosomal protein that is essential for centriole duplication, assembly, and elongation.[1][2][3]

CEP120 exhibits dynamic localization throughout the cell cycle. It is preferentially enriched on the daughter centriole in G0/G1 and becomes enriched on newly forming procentrioles during S-phase.[1][4] This asymmetric localization is critical for its function. Depletion of CEP120 leads to a failure in procentriole formation during S-phase, resulting in a progressive loss of centrioles over subsequent cell divisions.[1][4] In quiescent (G0) cells, CEP120 takes on an inhibitory role, preventing the untimely accumulation of PCM on the daughter centriole.[1][5] This guide explores these functions in detail, presenting the quantitative effects of CEP120 modulation on cell cycle parameters and centrosomal protein composition.

Quantitative Data on CEP120's Impact

The functional significance of CEP120 is underscored by the quantitative changes observed upon its depletion. These effects span cell cycle phase distribution, centriole number, and the composition of the pericentriolar material.

Effects on Cell Cycle Phase Distribution

Studies in mouse embryonic fibroblasts (MEFs) have shown that while CEP120 is critical for S-phase events (centriole duplication), its depletion in quiescent cells does not significantly alter the overall cell cycle profile. However, in specific proliferating cell types, its loss can lead to mitotic delays.

Table 1: Cell Cycle Phase Distribution in Quiescent MEFs After CEP120 Depletion[5]

Cell Line	Condition	% G0/G1 Phase	% S Phase	% G2/M Phase
MEF	Control siRNA	85.3%	8.2%	6.5%
MEF	Cep120 siRNA	86.1%	7.9%	6.0%

Data from FACS analysis of serum-starved MEFs 48 hours post-transfection. No significant differences were observed.

In contrast, conditional deletion of Cep120 in proliferating kidney stromal progenitors results in a marked increase in the G2/M population, indicating a delay in mitotic progression.[6]

Effects on Centriole Number

The primary and most dramatic effect of CEP120 depletion in cycling cells is a failure in centriole duplication, leading to a progressive loss of centrioles.

Table 2: Quantification of Centriole Number in Cycling Cells After CEP120 Depletion[4][5]

Cell Line	Condition	% Cells with 0 Centrioles	% Cells with 1 Centriole	% Cells with 2 Centrioles	% Cells with >2 Centrioles
MEF	Control shRNA (Day 9)	0%	2%	85%	13%
MEF	Cep120 shRNA (Day 9)	35%	55%	10%	0%
MEF	Control siRNA (48h)	1%	11%	78%	10%
MEF	Cep120 siRNA (48h)	15%	65%	18%	2%

Data compiled from studies using both shRNA-mediated stable knockdown and transient siRNA-mediated depletion.

Effects on Pericentriolar Material (PCM) Composition

In quiescent cells, CEP120 acts as a gatekeeper for PCM accumulation, particularly at the daughter centriole. Its depletion leads to a significant increase in the centrosomal levels of several key PCM components, while others, like γ -tubulin, remain unaffected.

Table 3: Fold Change in Centrosomal PCM Protein Levels After CEP120 Depletion in Quiescent MEFs[5]

PCM Protein	Overall Centrosomal Fold Increase	Fold Increase at Mother Centriole	Fold Increase at Daughter Centriole
Pericentrin	~2.5x	~1.5x	~4.0x
Cdk5Rap2	~6.0x	~2.0x	~8.0x
Ninein	~4.0x	~3.0x	~6.0x
Cep170	~4.0x	~4.0x	~3.5x
γ -Tubulin	No Significant Change	No Significant Change	No Significant Change

Fold change is calculated based on normalized fluorescence intensity from quantitative immunofluorescence microscopy compared to control siRNA-treated cells.

Signaling Pathways and Molecular Interactions

CEP120's function in cell cycle progression is mediated through its interaction with other proteins and its role in specific signaling pathways, primarily related to centriole duplication and maturation.

The Centriole Duplication Pathway

CEP120 is a crucial component of the machinery that drives centriole elongation. Its function is closely linked with Polo-like kinase 4 (PLK4), the master regulator of centriole duplication, and CPAP (SAS-4), another key elongation factor.^{[2][7]} More recent evidence from gastric cancer models suggests that CEP120 may regulate centrosome amplification by stabilizing PLK4. This occurs through a mechanism where CEP120 promotes the expression of the deubiquitinase USP54, which in turn deubiquitinates and stabilizes PLK4, preventing its degradation by the proteasome.^[8]

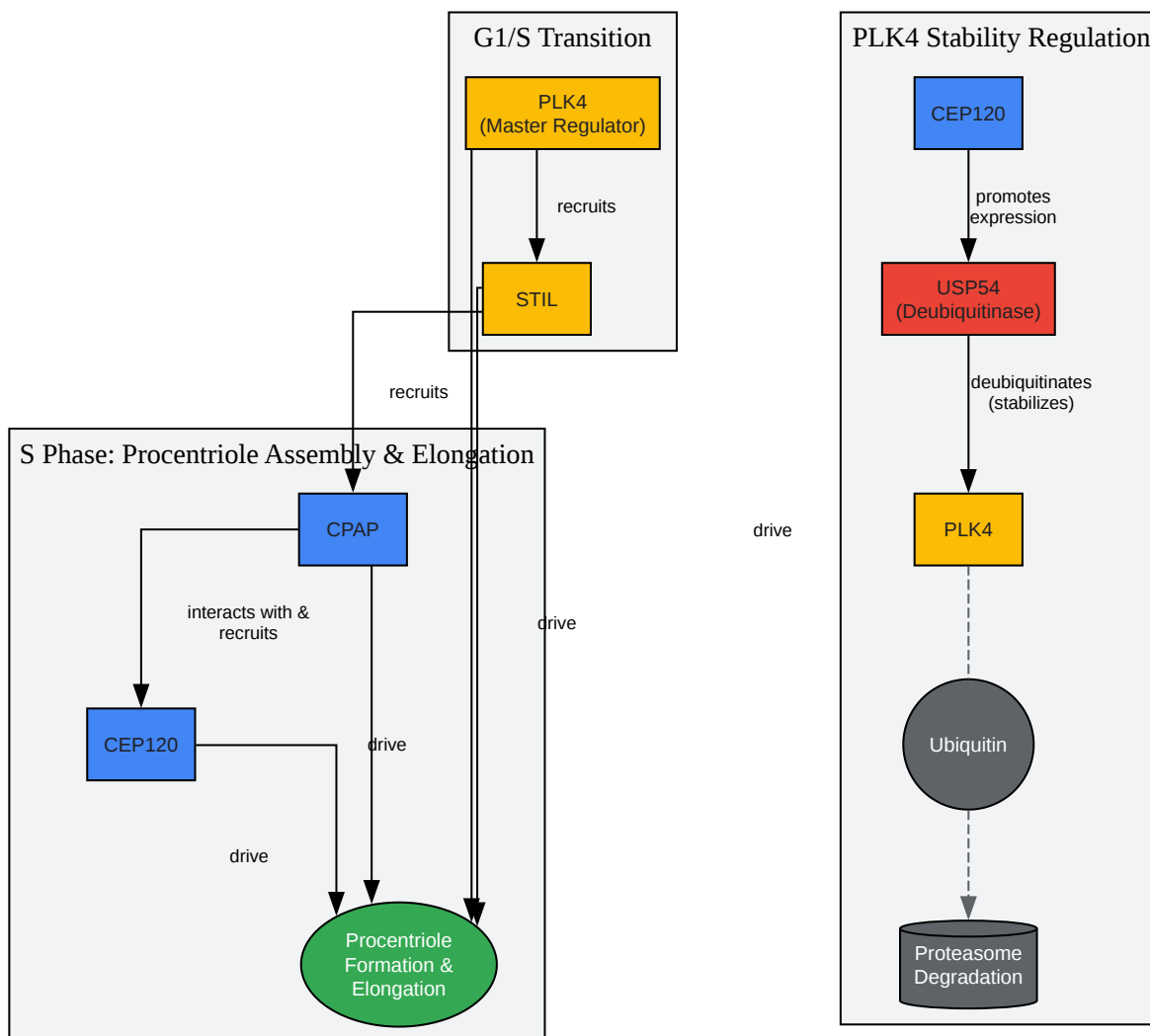

[Click to download full resolution via product page](#)

Diagram 1: CEP120 in the Centriole Duplication Pathway.

Inhibition of Daughter Centriole Maturation in Quiescence

In non-dividing (G₀) cells, CEP120 prevents the premature maturation of the daughter centriole. It achieves this by limiting the recruitment of PCM components like Pericentrin and Cdk5Rap2.[5] The loss of CEP120 leads to excessive PCM accumulation, increased microtubule nucleation, and subsequent defects in the formation of the primary cilium, a key sensory organelle. This inhibitory function is relieved at the G₁/S transition, allowing the daughter centriole to mature and begin the duplication process.[4] This regulatory role is distinct from the PCM recruitment that occurs at the G₂/M transition, which is primarily driven by the kinase Plk1.[1]

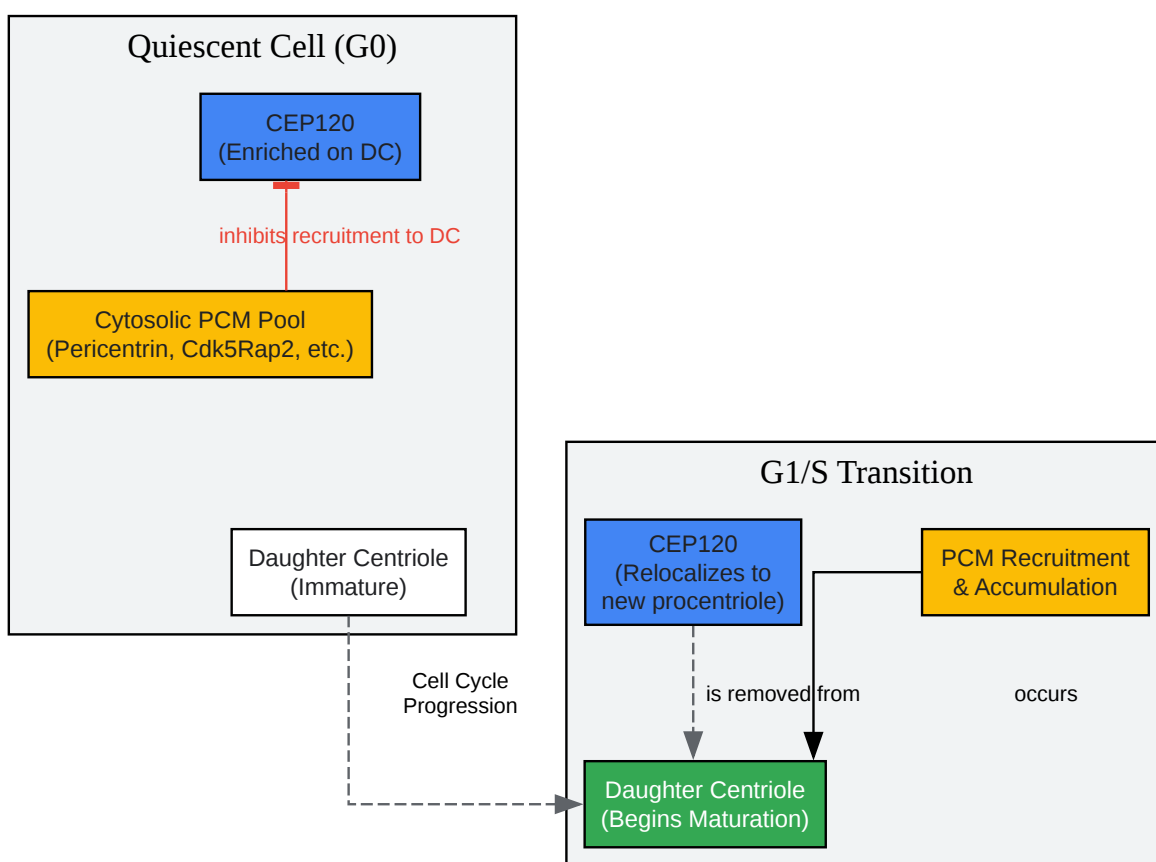

[Click to download full resolution via product page](#)

Diagram 2: CEP120's Inhibitory Role in Quiescence.

Key Experimental Protocols

This section provides detailed methodologies for foundational experiments used to study CEP120's role in cell cycle progression.

siRNA-mediated Depletion of CEP120

This protocol describes the transient knockdown of CEP120 in cultured mammalian cells, a common method to study its loss-of-function phenotype.

Materials:

- Mammalian cells (e.g., MEFs, RPE-1, U2OS)
- Complete growth medium (e.g., DMEM with 10% FBS)
- Opti-MEM I Reduced Serum Medium
- siRNA targeting CEP120 (and non-targeting control siRNA)
- Lipofectamine RNAiMAX transfection reagent
- 6-well tissue culture plates

Procedure:

- Cell Seeding: One day before transfection, seed cells in 6-well plates at a density that will result in 30-50% confluency at the time of transfection.
- siRNA-Lipid Complex Preparation (per well): a. In tube A, dilute 20-50 pmol of siRNA (CEP120 or control) into 100 μ L of Opti-MEM. b. In tube B, dilute 5 μ L of Lipofectamine RNAiMAX into 100 μ L of Opti-MEM. c. Combine the contents of tube A and tube B. Mix gently by pipetting and incubate for 15 minutes at room temperature to allow complexes to form.
- Transfection: a. Aspirate the culture medium from the cells. b. Add 800 μ L of fresh, antibiotic-free complete growth medium to each well. c. Add the 200 μ L siRNA-lipid complex mixture dropwise to each well. d. Gently rock the plate to ensure even distribution.

- Incubation and Analysis: Incubate the cells at 37°C in a CO2 incubator. Cells can be harvested for analysis (e.g., Western blot, immunofluorescence, FACS) 48-72 hours post-transfection.

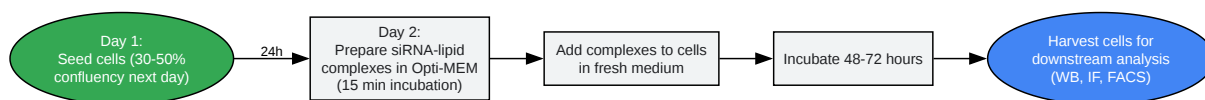

[Click to download full resolution via product page](#)

Diagram 3: Workflow for siRNA-mediated Depletion.

Cell Cycle Analysis by Flow Cytometry (FACS)

This protocol is used to determine the distribution of cells in different phases of the cell cycle based on their DNA content.

Materials:

- Transfected or control cells from a 6-well plate
- Phosphate-Buffered Saline (PBS)
- Trypsin-EDTA
- 70% Ethanol (ice-cold)
- Propidium Iodide (PI) staining solution (50 µg/mL PI, 100 µg/mL RNase A in PBS)
- FACS tubes
- Flow cytometer

Procedure:

- Cell Harvest: a. Aspirate medium and wash cells with PBS. b. Add 0.5 mL of Trypsin-EDTA and incubate for 3-5 minutes at 37°C to detach cells. c. Neutralize trypsin with 1 mL of

complete medium and transfer the cell suspension to a 1.5 mL microfuge tube. d. Pellet cells by centrifugation at 300 x g for 5 minutes.

- Fixation: a. Discard the supernatant and wash the cell pellet with 1 mL of cold PBS. Centrifuge again. b. Resuspend the pellet in the residual PBS. c. While vortexing gently, add 1 mL of ice-cold 70% ethanol dropwise to fix the cells. d. Incubate at 4°C for at least 2 hours (or overnight).
- Staining: a. Pellet the fixed cells by centrifugation at 500 x g for 5 minutes. b. Discard the ethanol and wash the pellet with 1 mL of PBS. c. Resuspend the pellet in 0.5 mL of PI staining solution. d. Incubate in the dark at room temperature for 30 minutes.
- Analysis: Transfer the cell suspension to a FACS tube. Analyze the DNA content using a flow cytometer. Gate the populations corresponding to G0/G1 (2n DNA), S (>2n to <4n DNA), and G2/M (4n DNA) phases.

Quantitative Immunofluorescence of Centrosomal Proteins

This protocol allows for the visualization and quantification of protein levels specifically at the centrosome.

Materials:

- Cells grown on glass coverslips
- PBS
- 4% Paraformaldehyde (PFA) in PBS
- Permeabilization Buffer (0.2% Triton X-100 in PBS)
- Blocking Buffer (5% Bovine Serum Albumin in PBS)
- Primary antibodies (e.g., rabbit anti-Pericentrin, mouse anti- γ -tubulin)
- Fluorescently-conjugated secondary antibodies (e.g., anti-rabbit Alexa Fluor 488, anti-mouse Alexa Fluor 594)

- DAPI solution
- Mounting medium
- Fluorescence microscope with image analysis software (e.g., ImageJ/Fiji)

Procedure:

- Fixation: a. Wash cells on coverslips twice with PBS. b. Fix with 4% PFA for 15 minutes at room temperature. c. Wash three times with PBS for 5 minutes each.
- Permeabilization & Blocking: a. Permeabilize cells with Permeabilization Buffer for 10 minutes. b. Wash three times with PBS. c. Block with Blocking Buffer for 1 hour at room temperature.
- Antibody Incubation: a. Dilute primary antibodies in Blocking Buffer. b. Invert coverslips onto a drop of the primary antibody solution on parafilm in a humidified chamber. c. Incubate overnight at 4°C. d. The next day, wash coverslips three times with PBS for 5 minutes each. e. Dilute fluorescently-conjugated secondary antibodies in Blocking Buffer. f. Incubate with secondary antibodies for 1 hour at room temperature in the dark. g. Wash three times with PBS for 5 minutes each in the dark.
- Mounting and Imaging: a. Stain nuclei with DAPI for 5 minutes. b. Rinse briefly in PBS. c. Mount the coverslip onto a glass slide using mounting medium. d. Image using a fluorescence or confocal microscope.
- Quantification (using ImageJ/Fiji): a. Open the image and split the channels. b. Identify centrosomes based on γ -tubulin or another centriolar marker. c. Draw a region of interest (ROI) of a fixed size around each centrosome. d. Measure the integrated density within the ROI for the protein of interest (e.g., Pericentrin). e. Measure the mean fluorescence of a background region near the centrosome. f. Calculate the corrected total cell fluorescence (CTCF) = Integrated Density – (Area of ROI * Mean background fluorescence). g. Normalize the CTCF values of the protein of interest to a control condition.

Conclusion and Future Directions

CEP120 is an indispensable protein for the maintenance of centrosome number and function, thereby playing a pivotal role in cell cycle progression. Its primary function in cycling cells is to facilitate centriole duplication and elongation during S-phase, a process it coordinates with CPAP and is linked to the stability of the master kinase PLK4. In a striking functional duality, CEP120 acts as a crucial inhibitor of premature daughter centriole maturation in quiescent cells, safeguarding cellular homeostasis and proper ciliogenesis.

While its role in centriole biogenesis is well-established, the precise mechanisms of its regulation by the core cell cycle machinery, such as Cdk1 and Aurora kinases, remain to be fully elucidated. Direct phosphorylation of CEP120 by these kinases has not been consistently demonstrated in large-scale proteomic screens, suggesting a more complex regulatory network may be at play. Future research should focus on identifying the upstream signals that govern CEP120's cell cycle-dependent localization and function. Understanding these regulatory networks will not only provide deeper insights into the fundamental process of cell division but may also unveil novel therapeutic targets for ciliopathies and cancers associated with centrosome abnormalities.

Need Custom Synthesis?

BenchChem offers custom synthesis for rare earth carbides and specific isotopic labeling.

Email: info@benchchem.com or [Request Quote Online](#).

References

- [1. Proteomic Analysis Reveals a PLK1-Dependent G2/M Degradation Program and Links PKA-AKAP2 to Cell Cycle Control - PMC \[pmc.ncbi.nlm.nih.gov\]](#)
- [2. Proteomic screen defines the Polo-box domain interactome and identifies Rock2 as a Plk1 substrate - PMC \[pmc.ncbi.nlm.nih.gov\]](#)
- [3. researchgate.net \[researchgate.net\]](#)
- [4. The right place at the right time: Aurora B kinase localization to centromeres and kinetochores - PMC \[pmc.ncbi.nlm.nih.gov\]](#)
- [5. Identification of cell cycle-dependent phosphorylation sites on the anaphase-promoting complex/cyclosome by mass spectrometry - PubMed \[pubmed.ncbi.nlm.nih.gov\]](#)

- [6. High resolution profiling of cell cycle-dependent protein and phosphorylation abundance changes in non-transformed cells - PMC \[pmc.ncbi.nlm.nih.gov\]](#)
- [7. PRIDE - PRoteomics IDentifications Database \[ebi.ac.uk\]](#)
- [8. Global analysis of Cdk1 substrate phosphorylation sites provides insights into evolution - PMC \[pmc.ncbi.nlm.nih.gov\]](#)
- To cite this document: BenchChem. [The Role of CEP120 in Cell Cycle Progression: A Technical Guide]. BenchChem, [2026]. [Online PDF]. Available at: [\[https://www.benchchem.com/product/b12391809/docs#the-role-of-cep120-in-cell-cycle-progression-a-technical-guide\]](https://www.benchchem.com/product/b12391809/docs#the-role-of-cep120-in-cell-cycle-progression-a-technical-guide)

Disclaimer & Data Validity:

The information provided in this document is for Research Use Only (RUO) and is strictly not intended for diagnostic or therapeutic procedures. While BenchChem strives to provide accurate protocols, we make no warranties, express or implied, regarding the fitness of this product for every specific experimental setup.

Technical Support: The protocols provided are for reference purposes. Unsure if this reagent suits your experiment?

Need Industrial/Bulk Grade? [Request Custom Synthesis Quote](#)

BenchChem

Our mission is to be the trusted global source of essential and advanced chemicals, empowering scientists and researchers to drive progress in science and industry.

Contact

Address: 3281 E Guasti Rd
Ontario, CA 91761, United States
Phone: (601) 213-4426
Email: info@benchchem.com

Contact our Ph.D. Support Team for a compatibility check