

Technical Support Center: Refining Pcsk9-IN-9 Treatment Duration In Vitro

Author: BenchChem Technical Support Team. **Date:** April 2026

Compound of Interest

Compound Name: *Pcsk9-IN-9*

Cat. No.: *B12391094*

[Get Quote](#)

This technical support center provides troubleshooting guidance and frequently asked questions (FAQs) for researchers utilizing **Pcsk9-IN-9** in in vitro experiments. The information is designed to help refine treatment duration and address common issues encountered during experimental procedures.

Frequently Asked Questions (FAQs)

Q1: What is the mechanism of action of **Pcsk9-IN-9**?

A1: **Pcsk9-IN-9** is a small molecule inhibitor of Proprotein Convertase Subtilisin/Kexin type 9 (PCSK9). PCSK9 is a secreted protein that binds to the Low-Density Lipoprotein Receptor (LDLR) on the surface of hepatocytes. This binding targets the LDLR for degradation in lysosomes, thereby reducing the number of LDLRs available to clear LDL cholesterol from the circulation.[1][2] **Pcsk9-IN-9** works by disrupting the interaction between PCSK9 and the LDLR, which prevents LDLR degradation and leads to increased LDLR levels on the cell surface and enhanced LDL uptake.

Q2: What is a typical starting point for **Pcsk9-IN-9** treatment duration in vitro?

A2: Based on studies of PCSK9-mediated LDLR degradation, a treatment duration of 12 to 24 hours is often sufficient to observe a significant effect on LDLR protein levels.[3] For initial experiments, a 24-hour incubation period with **Pcsk9-IN-9** is a reasonable starting point to assess its efficacy in preventing PCSK9-induced LDLR degradation.

Q3: How can I determine the optimal concentration of **Pcsk9-IN-9** to use?

A3: To determine the optimal concentration, a dose-response experiment is recommended. This involves treating cells with a range of **Pcsk9-IN-9** concentrations and measuring the effect on LDLR protein levels or LDL uptake. A similar small molecule inhibitor, Pcsk9-IN-11, has a reported IC₅₀ of 5.7 μM in HepG2 cells. This suggests that a concentration range from nanomolar to low micromolar would be appropriate for initial dose-response studies with **Pcsk9-IN-9**.

Q4: Can I perform a time-course experiment to refine the treatment duration?

A4: Yes, a time-course experiment is highly recommended. This involves treating cells with a fixed concentration of **Pcsk9-IN-9** and harvesting them at various time points (e.g., 4, 8, 12, 24, and 48 hours) to measure the effect on LDLR protein levels. This will help you identify the shortest effective treatment duration for your specific cell type and experimental conditions.

Q5: What cell lines are suitable for in vitro studies with **Pcsk9-IN-9**?

A5: Human hepatocyte-derived cell lines such as HepG2 and Huh7 are commonly used as they endogenously express PCSK9 and LDLR. These cells provide a physiologically relevant model to study the effects of PCSK9 inhibitors on LDLR regulation and LDL uptake.

Troubleshooting Guide

Issue	Possible Cause(s)	Suggested Solution(s)
<p>No observable increase in LDLR protein levels after Pcsk9-IN-9 treatment.</p>	<p>1. Suboptimal inhibitor concentration: The concentration of Pcsk9-IN-9 may be too low to effectively inhibit PCSK9. 2. Insufficient treatment duration: The incubation time may be too short to see a significant effect on LDLR protein turnover. 3. Low PCSK9 expression/activity: The endogenous levels of PCSK9 in your cell line may be too low to cause significant LDLR degradation, thus masking the effect of the inhibitor. 4. Inactive compound: The Pcsk9-IN-9 compound may have degraded.</p>	<p>1. Perform a dose-response experiment to determine the optimal concentration. Start with a range based on the IC50 of similar compounds (e.g., 0.1 - 20 μM). 2. Perform a time-course experiment, extending the incubation period up to 48 hours. 3. Consider co-treating cells with recombinant human PCSK9 to induce robust LDLR degradation, which will make the inhibitory effect of Pcsk9-IN-9 more apparent. 4. Ensure proper storage of the compound as per the manufacturer's instructions and consider purchasing a fresh batch.</p>
<p>High variability between replicate wells in the LDL uptake assay.</p>	<p>1. Uneven cell seeding: Inconsistent cell numbers across wells can lead to variability in LDL uptake. 2. Cell detachment during washing steps: Aggressive washing can lead to cell loss, particularly in loosely adherent cell lines. 3. Issues with fluorescently-labeled LDL: The fluorescent dye may not be covalently attached and could be leaching from the LDL particles, leading to non-specific signals.[4] Aggregation</p>	<p>1. Ensure a single-cell suspension and use a consistent seeding density for all wells. Allow cells to adhere and reach a similar confluency before starting the experiment. 2. Use gentle washing techniques, such as adding and removing buffer slowly from the side of the well. Consider using poly-D-lysine coated plates to improve cell adherence.[4] 3. Use high-quality, validated fluorescently-labeled LDL. Avoid vortexing</p>

of the labeled LDL can also cause uneven uptake.[4]

the LDL solution to prevent aggregation.[4] Include appropriate controls, such as wells with unlabeled LDL to assess non-specific uptake.

Unexpected decrease in cell viability after treatment.

1. Inhibitor cytotoxicity: High concentrations of Pcsk9-IN-9 may be toxic to the cells. 2. Solvent toxicity: The solvent used to dissolve Pcsk9-IN-9 (e.g., DMSO) may be at a toxic concentration.

1. Perform a cell viability assay (e.g., MTT or LDH assay) in parallel with your main experiment to assess the cytotoxicity of Pcsk9-IN-9 at different concentrations. 2. Ensure the final concentration of the solvent in the cell culture medium is low (typically \leq 0.1% for DMSO) and include a vehicle control in your experiments.

Quantitative Data Summary

The following tables provide representative data for a small molecule PCSK9 inhibitor, Pcsk9-IN-11, which can serve as a reference for designing experiments with **Pcsk9-IN-9**.

Table 1: Dose-Dependent Inhibition of PCSK9

Inhibitor Concentration (μ M)	% Inhibition of PCSK9 Activity (Relative to Vehicle Control)
0.1	15%
0.5	35%
1.0	50%
5.0	85%
10.0	95%
IC50	\sim 1.0 μ M (Hypothetical)

Note: The IC50 for the similar compound Pcsk9-IN-11 is reported to be 5.7 μ M in HepG2 cells.

Table 2: Time-Dependent Effect on LDLR Protein Levels

Treatment Duration (hours)	Fold Increase in LDLR Protein (Relative to t=0)
0	1.0
4	1.2
8	1.8
12	2.5
24	3.2
48	3.1

Experimental Protocols

Western Blot for LDLR Protein Levels

This protocol describes the measurement of LDLR protein levels in cell lysates following treatment with **Pcsk9-IN-9**.

Materials:

- HepG2 cells
- Complete culture medium
- **Pcsk9-IN-9**
- Recombinant human PCSK9 (optional)
- RIPA lysis buffer with protease inhibitors
- BCA protein assay kit
- SDS-PAGE gels and running buffer

- Transfer buffer and PVDF membrane
- Blocking buffer (e.g., 5% non-fat milk in TBST)
- Primary antibody against LDLR
- Primary antibody against a loading control (e.g., β -actin or GAPDH)
- HRP-conjugated secondary antibody
- Chemiluminescent substrate

Procedure:

- Cell Seeding: Seed HepG2 cells in 6-well plates and allow them to adhere and reach 70-80% confluency.
- Treatment:
 - For dose-response: Treat cells with increasing concentrations of **Pcsk9-IN-9** (e.g., 0, 0.1, 0.5, 1, 5, 10 μ M) for 24 hours.
 - For time-course: Treat cells with a fixed concentration of **Pcsk9-IN-9** (e.g., 5 μ M) for different durations (e.g., 0, 4, 8, 12, 24, 48 hours).
 - (Optional) To enhance the effect, pre-incubate the inhibitor with recombinant human PCSK9 (e.g., 10 μ g/mL) for 30 minutes before adding to the cells.[5]
- Cell Lysis: Wash cells with ice-cold PBS and lyse them with RIPA buffer containing protease inhibitors.
- Protein Quantification: Determine the protein concentration of each lysate using a BCA protein assay.
- SDS-PAGE and Western Blotting:
 - Load equal amounts of protein (e.g., 20-30 μ g) onto an SDS-PAGE gel.

- Separate the proteins by electrophoresis and transfer them to a PVDF membrane.
- Block the membrane with blocking buffer for 1 hour at room temperature.
- Incubate the membrane with the primary anti-LDLR antibody overnight at 4°C.
- Wash the membrane and incubate with the HRP-conjugated secondary antibody for 1 hour at room temperature.
- Wash the membrane again and detect the signal using a chemiluminescent substrate and an imaging system.
- Strip the membrane and re-probe with the loading control antibody.
- Data Analysis: Quantify the band intensities using densitometry software. Normalize the LDLR band intensity to the corresponding loading control band intensity.

Fluorescent LDL Uptake Assay

This protocol describes a cell-based assay to measure the uptake of fluorescently labeled LDL, which is an indicator of LDLR activity.

Materials:

- HepG2 cells
- Complete culture medium
- **Pcsk9-IN-9**
- Recombinant human PCSK9 (optional)
- Fluorescently labeled LDL (e.g., Dil-LDL or BODIPY-LDL)
- Unlabeled LDL (for competition control)
- Fluorescence microscope or plate reader

Procedure:

- Cell Seeding: Seed HepG2 cells in a 96-well black, clear-bottom plate and allow them to adhere overnight.
- Treatment: Treat the cells with **Pcsk9-IN-9** at various concentrations for the desired duration (e.g., 24 hours). Include a vehicle control and a positive control (e.g., a known PCSK9 inhibitor).
- LDL Uptake:
 - After the inhibitor treatment, replace the medium with fresh serum-free medium containing fluorescently labeled LDL (e.g., 10 µg/mL).
 - For a competition control, add a 20-fold excess of unlabeled LDL along with the fluorescently labeled LDL to a set of wells.
 - Incubate the cells for 3-4 hours at 37°C.
- Washing: Gently wash the cells three times with PBS to remove unbound fluorescent LDL.
- Signal Detection:
 - Microscope: Acquire images using a fluorescence microscope.
 - Plate Reader: Measure the fluorescence intensity using a plate reader with appropriate excitation and emission wavelengths.
- Data Analysis: Subtract the background fluorescence (from cells not treated with fluorescent LDL). The increase in fluorescence in **Pcsk9-IN-9**-treated cells compared to the vehicle control indicates enhanced LDL uptake.

Visualizations

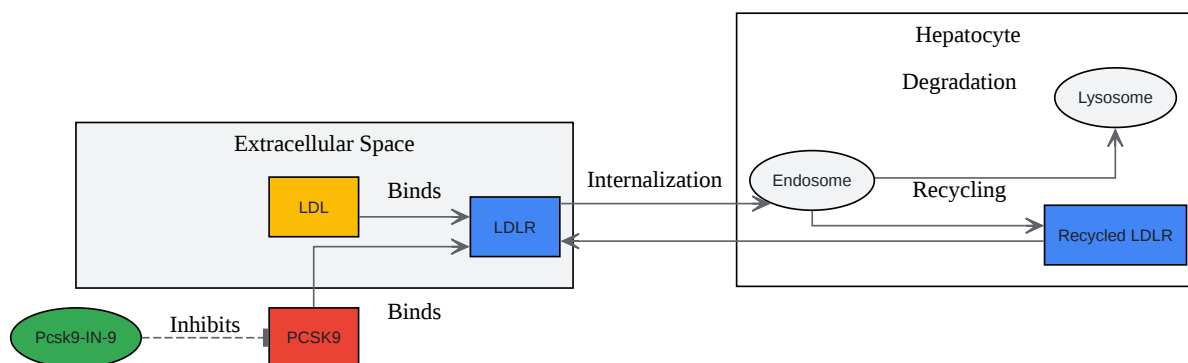

[Click to download full resolution via product page](#)

Caption: PCSK9 signaling pathway and the inhibitory action of **Pcsk9-IN-9**.

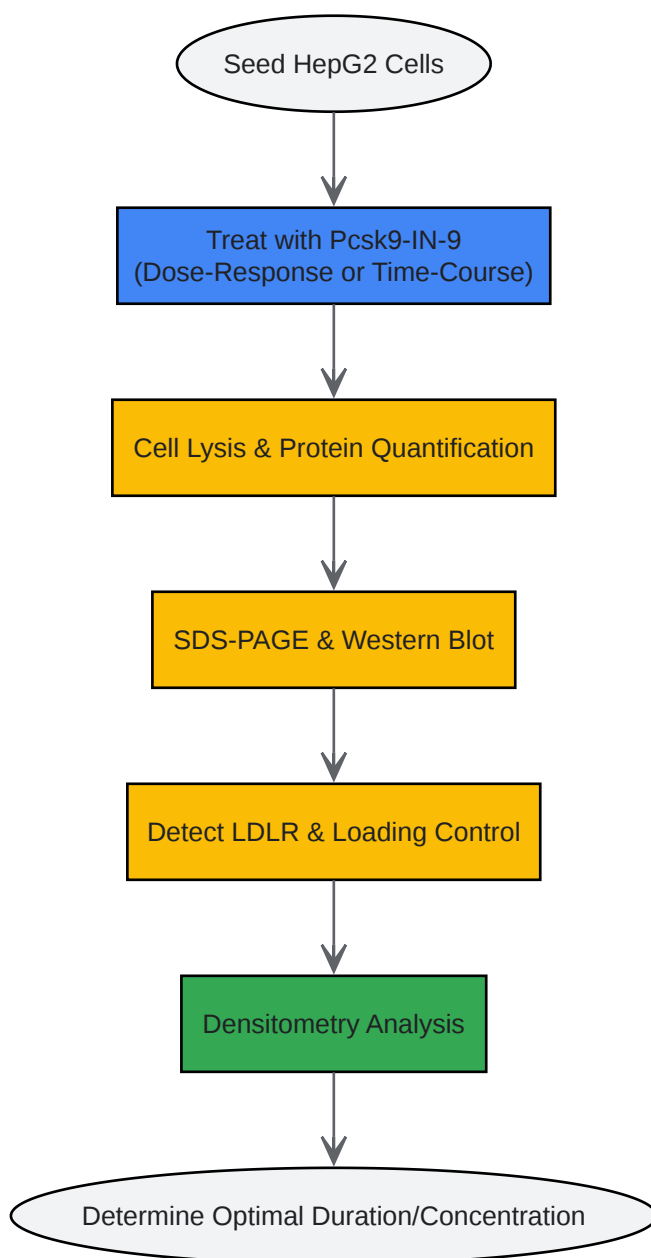

[Click to download full resolution via product page](#)

Caption: Experimental workflow for determining LDLR degradation.

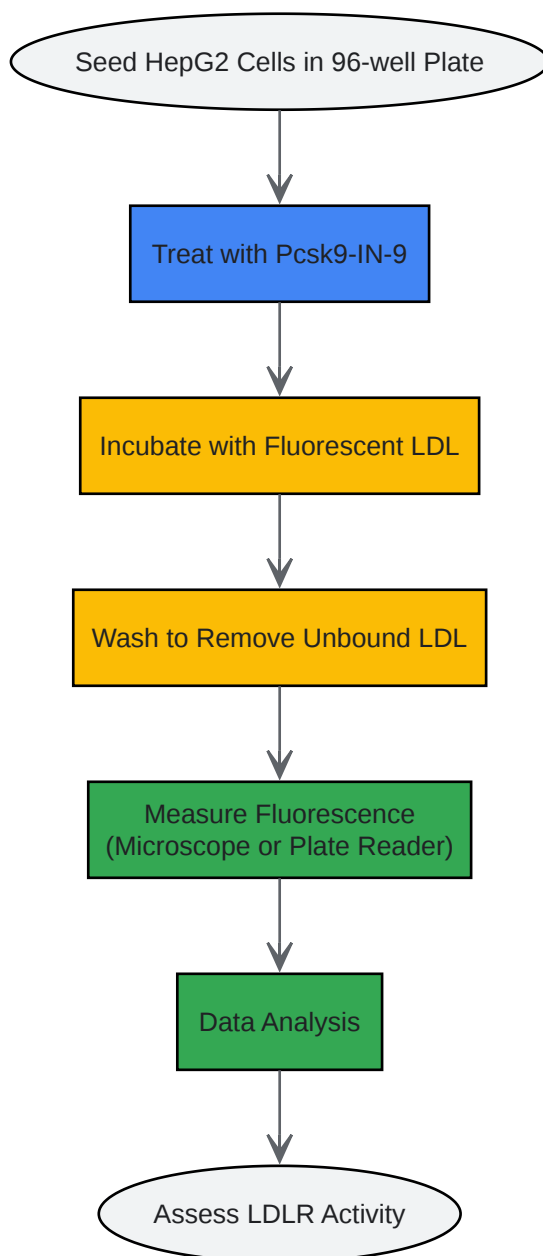

[Click to download full resolution via product page](#)

Caption: Experimental workflow for the fluorescent LDL uptake assay.

Need Custom Synthesis?

BenchChem offers custom synthesis for rare earth carbides and specific isotopic labeling.

Email: info@benchchem.com or [Request Quote Online](#).

References

- 1. The PCSK9 decade: Thematic Review Series: New Lipid and Lipoprotein Targets for the Treatment of Cardiometabolic Diseases - PMC [[pmc.ncbi.nlm.nih.gov](https://pubmed.ncbi.nlm.nih.gov/)]
- 2. PCSK9 and LDLR degradation: regulatory mechanisms in circulation and in cells - PMC [[pmc.ncbi.nlm.nih.gov](https://pubmed.ncbi.nlm.nih.gov/)]
- 3. A small-molecule inhibitor of PCSK9 transcription ameliorates atherosclerosis through the modulation of FoxO1/3 and HNF1 α - PMC [[pmc.ncbi.nlm.nih.gov](https://pubmed.ncbi.nlm.nih.gov/)]
- 4. A Novel, Orally Bioavailable, Small-Molecule Inhibitor of PCSK9 With Significant Cholesterol-Lowering Properties In Vivo - PMC [[pmc.ncbi.nlm.nih.gov](https://pubmed.ncbi.nlm.nih.gov/)]
- 5. A New Strategy for Rapidly Screening Natural Inhibitors Targeting the PCSK9/LDLR Interaction In Vitro - PMC [[pmc.ncbi.nlm.nih.gov](https://pubmed.ncbi.nlm.nih.gov/)]
- To cite this document: BenchChem. [Technical Support Center: Refining Pcsk9-IN-9 Treatment Duration In Vitro]. BenchChem, [2026]. [Online PDF]. Available at: [<https://www.benchchem.com/product/b12391094/docs#technical-support-center-refining-pcsk9-in-9-treatment-duration-in-vitro>]

Disclaimer & Data Validity:

The information provided in this document is for Research Use Only (RUO) and is strictly not intended for diagnostic or therapeutic procedures. While BenchChem strives to provide accurate protocols, we make no warranties, express or implied, regarding the fitness of this product for every specific experimental setup.

Technical Support: The protocols provided are for reference purposes. Unsure if this reagent suits your experiment?

Need Industrial/Bulk Grade? [Request Custom Synthesis Quote](#)

BenchChem

Our mission is to be the trusted global source of essential and advanced chemicals, empowering scientists and researchers to drive progress in science and industry.

Contact

Address: 3281 E Guasti Rd

Ontario, CA 91761, United States

Phone: (601) 213-4426

Email: info@benchchem.com

[Contact our Ph.D. Support Team for a compatibility check](#)