

Technical Support Center: Novel Antitrypanosomal Compound Screening

Author: BenchChem Technical Support Team. **Date:** April 2026

Compound of Interest

Compound Name: *Antitrypanosomal agent 11*

Cat. No.: *B12391015*

[Get Quote](#)

This technical support center provides troubleshooting guidance and frequently asked questions (FAQs) for researchers and drug development professionals working with novel antitrypanosomal compounds. Our goal is to help you overcome common experimental hurdles and effectively characterize your compounds of interest.

Frequently Asked Questions (FAQs)

Q1: What are the key initial assays for evaluating a novel antitrypanosomal compound?

A1: The initial assessment of a new compound typically involves a two-pronged approach: determining its potency against the parasite and its toxicity to mammalian cells. This is often achieved by calculating the 50% inhibitory concentration (IC50) against a culture of *Trypanosoma brucei* and the 50% cytotoxic concentration (CC50) against a mammalian cell line (e.g., HeLa, HEK293, or HepG2). The ratio of these two values (CC50/IC50) gives the Selectivity Index (SI), a critical measure of the compound's therapeutic potential.

Q2: Which strain of *Trypanosoma brucei* should I use for initial screening?

A2: For high-throughput screening, the bloodstream form of *Trypanosoma brucei brucei* is commonly used. Strains like 427 are well-characterized and widely utilized. It is also advisable

to confirm activity against clinically relevant subspecies, such as *T. b. rhodesiense* and *T. b. gambiense*, at a later stage.

Q3: My compound shows high potency but also high cytotoxicity. What does this mean?

A3: High potency (low IC₅₀) is a desirable characteristic, but concurrent high cytotoxicity (low CC₅₀) suggests that the compound may be acting on a target that is conserved between the parasite and host cells, or that it has a non-specific mechanism of action. This results in a low Selectivity Index (SI), indicating a narrow therapeutic window and a higher likelihood of off-target effects. Further investigation into the mechanism of action and structure-activity relationship (SAR) studies are necessary to improve selectivity.

Q4: What are some known off-target effects of current antitrypanosomal drugs?

A4: Many current antitrypanosomal drugs have significant side effects due to off-target activities. For instance, melarsoprol, an arsenic derivative, can cause reactive encephalopathy. Pentamidine is known to induce a range of issues including hypoglycemia, hypotension, and nephrotoxicity. These toxicities often arise from the drugs interacting with host cell components, highlighting the need for more selective novel compounds.

Troubleshooting Guides

Problem 1: Inconsistent IC₅₀/EC₅₀ Values in Antitrypanosomal Assays

Possible Causes:

- **Cell Culture Variability:** Inconsistent parasite density at the start of the assay, or variations in the growth phase of the parasites.
- **Compound Solubility:** Poor solubility of the test compound can lead to inaccurate concentrations in the assay medium.
- **Assay Conditions:** Fluctuations in incubation time, temperature, or CO₂ levels.^[1]
- **Reagent Issues:** Degradation of viability reagents (e.g., AlamarBlue/resazurin) due to light exposure or improper storage.^{[2][3]}

- Pipetting Errors: Inaccurate dispensing of compounds, cells, or reagents.

Recommended Solutions:

- Standardize Cell Seeding: Ensure a consistent starting cell density for each experiment. Use parasites in the mid-logarithmic growth phase for optimal and reproducible results.
- Verify Compound Solubility: Check the solubility of your compound in the assay medium. If necessary, use a co-solvent like DMSO, but keep the final concentration consistent across all wells and typically below 0.5% to avoid solvent-induced toxicity.
- Control Assay Parameters: Strictly adhere to the established incubation times and environmental conditions. Use a well-calibrated incubator.
- Proper Reagent Handling: Store reagents as recommended by the manufacturer, protecting light-sensitive reagents from light.[\[2\]](#)[\[3\]](#)
- Perform Quality Control: Use a reference compound with a known IC50 value in each assay to monitor for inter-assay variability.

Problem 2: High Background Signal in AlamarBlue (Resazurin) Viability Assay

Possible Causes:

- Reagent Degradation: The AlamarBlue reagent (resazurin) can degrade if exposed to light for prolonged periods, leading to auto-reduction and a high background signal.[\[2\]](#)[\[3\]](#)
- Media Interference: Some components in the culture medium can react with the reagent.[\[4\]](#)
- Microbial Contamination: Bacteria or fungi in the cell culture can also reduce resazurin, leading to false-positive signals.[\[4\]](#)[\[5\]](#)

Recommended Solutions:

- Protect Reagent from Light: Always store and handle AlamarBlue in the dark.

- **Include Media-Only Controls:** For every plate, include control wells that contain only the culture medium and the AlamarBlue reagent (no cells). Subtract the average signal from these wells from all other experimental wells.[4]
- **Ensure Aseptic Technique:** Maintain sterile conditions during the assay to prevent microbial contamination. Regularly check cultures for any signs of contamination.

Problem 3: Compound Shows High Cytotoxicity in Mammalian Cells

Possible Causes:

- **Non-Specific Mechanism of Action:** The compound may be targeting a fundamental cellular process common to both trypanosomes and mammalian cells (e.g., DNA replication, protein synthesis).
- **Mitochondrial Toxicity:** The compound might be disrupting mitochondrial function in host cells, which is a common off-target effect.
- **Off-Target Kinase Inhibition:** Many antitrypanosomal compounds target parasite kinases. Due to conserved ATP-binding sites, these can also inhibit human kinases.

Recommended Solutions:

- **Secondary and Counter-Screening:** Test the compound against a panel of mammalian cell lines from different tissues to assess broad-spectrum cytotoxicity. Screen against a panel of human kinases or other potential off-target protein families to identify unintended targets.
- **Mechanism of Action Studies:** Investigate the compound's effect on specific cellular pathways in both trypanosomes and mammalian cells. Assays for mitochondrial membrane potential (e.g., JC-1 assay), apoptosis (e.g., caspase activity assays), and cell cycle analysis can provide valuable insights.
- **Structure-Activity Relationship (SAR) Studies:** Synthesize and test analogues of the compound to identify modifications that reduce host cell toxicity while retaining or improving antitrypanosomal activity. This is a key part of the hit-to-lead optimization process.[6]

Data Presentation: Efficacy and Selectivity of Novel Antitrypanosomal Compounds

Compound Class	Example Compound	Target/Mechanism of Action	IC50 vs. T. brucei (µM)	CC50 vs. Mammalian Cells (µM)	Cell Line	Selectivity Index (SI)	Reference
Tetracyclic Iridoids	Molucidin	Apoptosis induction, cell cycle alteration	1.27	4.74 - 14.24	Various	3.7 - 11.2	[7]
Tetracyclic Iridoids	ML-F52	Apoptosis induction, cell cycle alteration	0.43	4.74 - 14.24	Various	11.0 - 33.1	[7]
N-Alkylamides	Tortodofuordioxamide	Unknown	3.2	>292	RAW 264.7	91.3	[8]
N-Alkylamides	Tortodofuorpyramide	Unknown	4.5	>314	RAW 264.7	69.9	[8]

Experimental Protocols

Protocol 1: In Vitro Antitrypanosomal Activity Assay (AlamarBlue/Resazurin)

This protocol determines the 50% inhibitory concentration (IC50) of a compound against bloodstream form *Trypanosoma brucei*.

Materials:

- *T. brucei brucei* (e.g., strain 427) culture in HMI-9 medium
- HMI-9 medium with 10% Fetal Bovine Serum (FBS)
- Test compounds dissolved in DMSO
- Pentamidine or diminazene aceturate (positive control)
- AlamarBlue reagent
- 96-well flat-bottom plates
- Humidified incubator (37°C, 5% CO₂)
- Fluorescence plate reader (Excitation: 530-560 nm, Emission: 590 nm)

Methodology:

- Cell Preparation: Culture *T. brucei* to a mid-log phase. Count the parasites and adjust the concentration to 2×10^5 cells/mL in fresh HMI-9 medium.
- Compound Dilution: Prepare a serial dilution of the test compounds in HMI-9 medium. The final DMSO concentration should not exceed 0.5%.
- Plate Seeding:
 - Add 100 μ L of the cell suspension (2×10^4 cells) to each well of a 96-well plate.
 - Add 100 μ L of the serially diluted compounds to the corresponding wells.
 - Include wells for a positive control (e.g., pentamidine), a negative control (cells with medium + DMSO), and a blank (medium only).
- Incubation: Incubate the plate for 48 hours at 37°C in a 5% CO₂ incubator.
- Addition of AlamarBlue: Add 20 μ L of AlamarBlue reagent to each well.
- Second Incubation: Incubate the plate for an additional 24 hours under the same conditions.

[9]

- Fluorescence Measurement: Read the fluorescence at an excitation wavelength of 530-560 nm and an emission wavelength of 590 nm.
- Data Analysis:
 - Subtract the blank values from all wells.
 - Calculate the percentage of growth inhibition relative to the negative control.
 - Plot the percentage of inhibition against the compound concentration and determine the IC50 value using non-linear regression analysis.

Protocol 2: Mammalian Cell Cytotoxicity Assay (MTT)

This protocol measures the 50% cytotoxic concentration (CC50) of a compound on a mammalian cell line.

Materials:

- Mammalian cell line (e.g., HEK293, HepG2) in appropriate culture medium
- Test compounds dissolved in DMSO
- Doxorubicin or another known cytotoxic agent (positive control)
- MTT (3-(4,5-dimethylthiazol-2-yl)-2,5-diphenyltetrazolium bromide) solution (5 mg/mL in PBS)
- Solubilization solution (e.g., DMSO or a solution of 10% SDS in 0.01 M HCl)
- 96-well flat-bottom plates
- Humidified incubator (37°C, 5% CO₂)
- Microplate reader (absorbance at 570 nm)

Methodology:

- **Cell Seeding:** Seed the mammalian cells into a 96-well plate at a density of 5,000-10,000 cells per well in 100 μ L of medium. Incubate for 24 hours to allow for cell attachment.
- **Compound Addition:** Add 100 μ L of medium containing serial dilutions of the test compounds to the wells. Include positive and negative controls.
- **Incubation:** Incubate the plate for 48-72 hours at 37°C in a 5% CO₂ incubator.
- **MTT Addition:** Remove the medium and add 100 μ L of fresh medium and 10 μ L of MTT solution to each well.[\[10\]](#)
- **Formazan Crystal Formation:** Incubate for 3-4 hours at 37°C. During this time, viable cells will convert the yellow MTT into purple formazan crystals.[\[10\]](#)
- **Solubilization:** Add 100 μ L of the solubilization solution to each well and mix thoroughly to dissolve the formazan crystals.[\[10\]](#)[\[11\]](#)
- **Absorbance Measurement:** Read the absorbance at 570 nm.
- **Data Analysis:** Calculate the percentage of cell viability relative to the untreated control and determine the CC₅₀ value using non-linear regression.

Visualizations

Signaling Pathways and Workflows

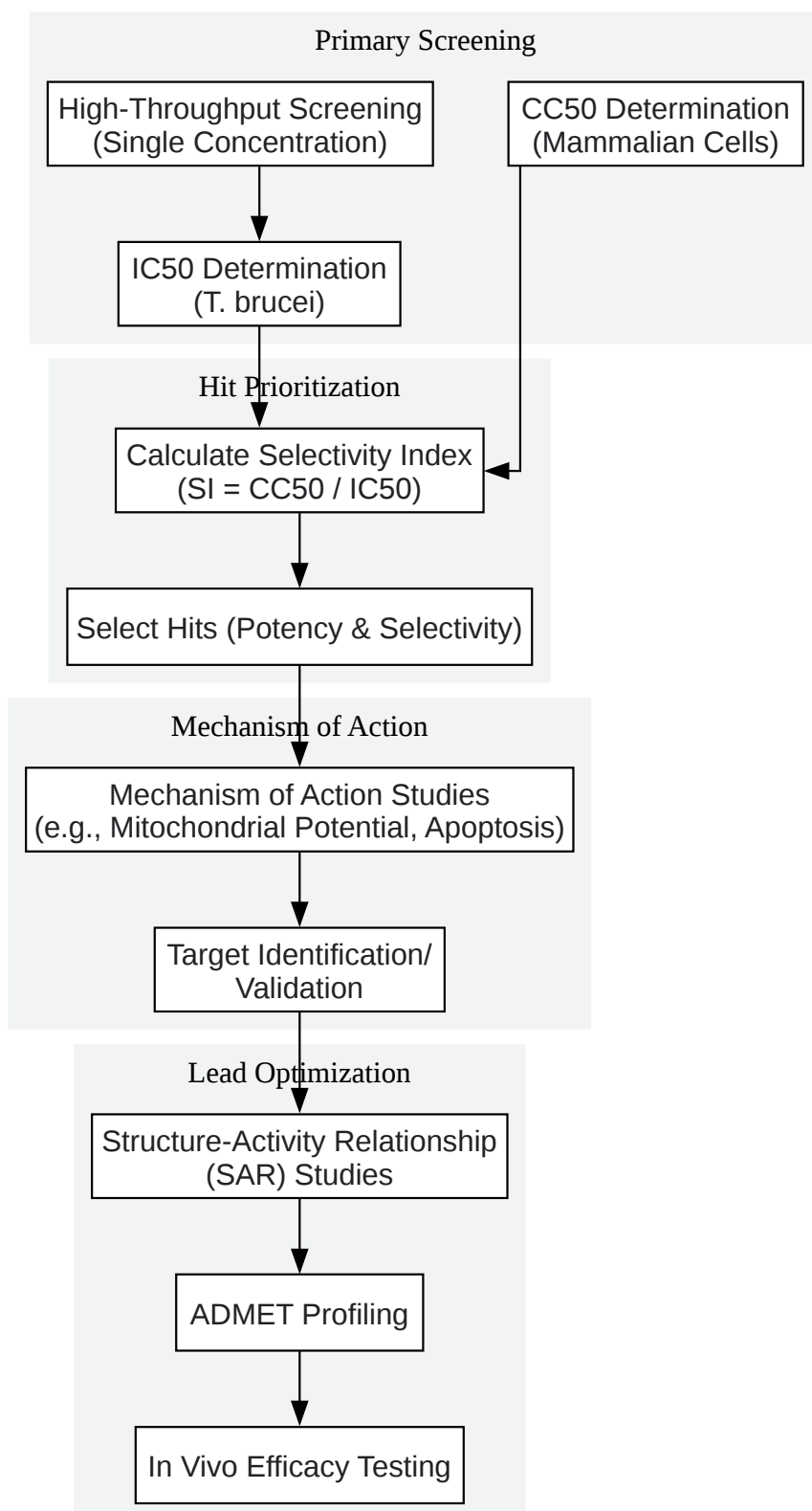

[Click to download full resolution via product page](#)

Caption: General experimental workflow for antitrypanosomal drug discovery.

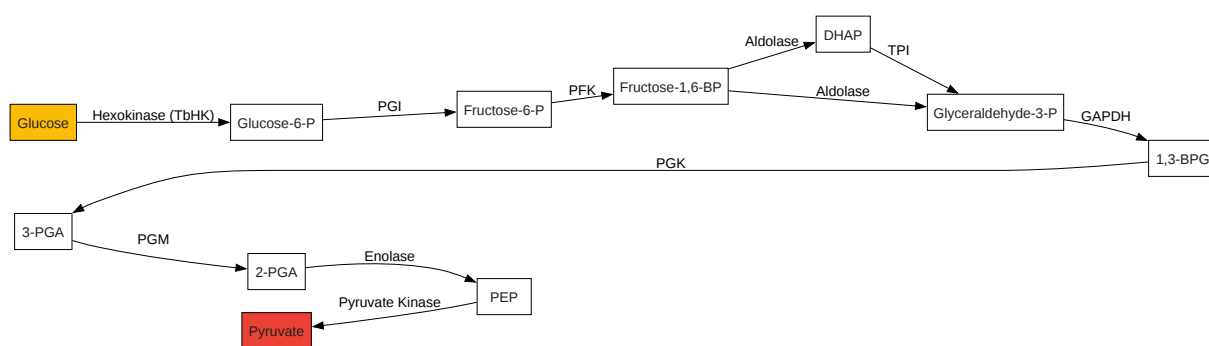

[Click to download full resolution via product page](#)

Caption: Simplified glycolysis pathway in *Trypanosoma brucei*.^{[8][12][13][14]}

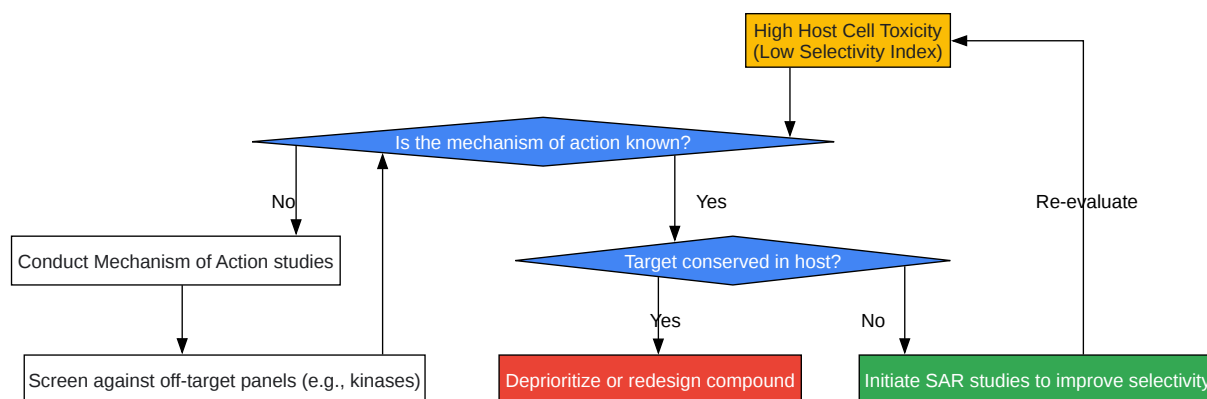

[Click to download full resolution via product page](#)

Caption: Decision tree for addressing high host cell toxicity.

Need Custom Synthesis?

BenchChem offers custom synthesis for rare earth carbides and specific isotopic labeling.

Email: info@benchchem.com or [Request Quote Online](#).

References

- 1. [Assessment of Cell Viability in Drug Therapy: IC50 and Other New Time-Independent Indices for Evaluating Chemotherapy Efficacy - PMC \[pmc.ncbi.nlm.nih.gov\]](#)
- 2. [documents.thermofisher.com \[documents.thermofisher.com\]](#)
- 3. [Cell Viability, Proliferation, Cryopreservation, and Apoptosis Support—Troubleshooting | Thermo Fisher Scientific - HK \[thermofisher.com\]](#)
- 4. [researchgate.net \[researchgate.net\]](#)
- 5. [bio-rad-antibodies.com \[bio-rad-antibodies.com\]](#)

- [6. excelra.com \[excelra.com\]](https://www.excelra.com)
- [7. What controls glycolysis in bloodstream form Trypanosoma brucei? - PubMed \[pubmed.ncbi.nlm.nih.gov\]](https://pubmed.ncbi.nlm.nih.gov/)
- [8. researchgate.net \[researchgate.net\]](https://www.researchgate.net)
- [9. research-repository.griffith.edu.au \[research-repository.griffith.edu.au\]](https://research-repository.griffith.edu.au)
- [10. MTT Assay Protocol for Cell Viability and Proliferation \[merckmillipore.com\]](https://www.merckmillipore.com)
- [11. Cell Viability Assays - Assay Guidance Manual - NCBI Bookshelf \[ncbi.nlm.nih.gov\]](https://www.ncbi.nlm.nih.gov/)
- [12. Glycolysis in the African Trypanosome: Targeting Enzymes and Their Subcellular Compartments for Therapeutic Development - PMC \[pmc.ncbi.nlm.nih.gov\]](https://pubmed.ncbi.nlm.nih.gov/)
- [13. Glycolysis as a target for the design of new anti-trypanosome drugs - PubMed \[pubmed.ncbi.nlm.nih.gov\]](https://pubmed.ncbi.nlm.nih.gov/)
- [14. spandidos-publications.com \[spandidos-publications.com\]](https://www.spandidos-publications.com)
- To cite this document: BenchChem. [Technical Support Center: Novel Antitrypanosomal Compound Screening]. BenchChem, [2026]. [Online PDF]. Available at: [\[https://www.benchchem.com/product/b12391015/docs#technical-support-center-novel-antitrypanosomal-compound-screening\]](https://www.benchchem.com/product/b12391015/docs#technical-support-center-novel-antitrypanosomal-compound-screening)

Disclaimer & Data Validity:

The information provided in this document is for Research Use Only (RUO) and is strictly not intended for diagnostic or therapeutic procedures. While BenchChem strives to provide accurate protocols, we make no warranties, express or implied, regarding the fitness of this product for every specific experimental setup.

Technical Support: The protocols provided are for reference purposes. Unsure if this reagent suits your experiment?

Need Industrial/Bulk Grade? [Request Custom Synthesis Quote](#)

BenchChem

Our mission is to be the trusted global source of essential and advanced chemicals, empowering scientists and researchers to drive progress in science and industry.

Contact

Address: 3281 E Guasti Rd

Ontario, CA 91761, United States

Phone: (601) 213-4426

Email: info@benchchem.com

[Contact our Ph.D. Support Team for a compatibility check](#)