

Technical Support Center: Influenza NP (266-274) T-Cell Stimulation

Author: BenchChem Technical Support Team. **Date:** April 2026

Compound of Interest

Compound Name: *Influenza virus NP (266-274)*

Cat. No.: *B12391109*

[Get Quote](#)

Welcome to the technical support center for troubleshooting low T-cell responses to influenza nucleoprotein (NP) (266-274) peptide stimulation. This resource is designed for researchers, scientists, and drug development professionals to identify and resolve common issues encountered during in vitro T-cell assays.

Frequently Asked Questions (FAQs)

Q1: What is the influenza NP (266-274) peptide and why is it used to stimulate T-cells?

A1: The influenza virus nucleoprotein (NP) is a conserved internal protein, making it a key target for T-cell-mediated immunity against various influenza A virus strains.^{[1][2]} The peptide sequence (266-274) represents a specific epitope, which is a part of the protein recognized by T-cells.^{[3][4]} It is frequently used in research to study the cellular immune response to influenza infection and in the development of universal influenza vaccines.^{[2][5]}

Q2: What are the common assays used to measure T-cell response to peptide stimulation?

A2: The most common assays are the Enzyme-Linked Immunospot (ELISpot) assay and Intracellular Cytokine Staining (ICS) followed by flow cytometry.^{[6][7][8]} The ELISpot assay

quantifies the number of cytokine-secreting cells (e.g., IFN- γ), while ICS allows for the identification of specific T-cell subsets (e.g., CD4+, CD8+) producing cytokines.[7][8]

Q3: What is considered a "low" T-cell response?

A3: A "low" response is relative and can depend on the assay, the donor's immune history, and experimental controls. Generally, a low response is characterized by a low frequency of responding cells (e.g., low spot count in ELISpot) or a weak signal (e.g., low cytokine expression in ICS) that is not significantly different from the negative control.[6] It's crucial to include positive and negative controls to properly interpret the results.[9]

Q4: Can cryopreservation of peripheral blood mononuclear cells (PBMCs) affect the T-cell response?

A4: Yes, the cryopreservation and thawing process can impact cell viability and function.[10] [11] Suboptimal cryopreservation techniques can lead to reduced cell recovery and a diminished capacity of T-cells to respond to stimulation.[10] It is essential to follow standardized protocols for freezing and thawing PBMCs to ensure reliable results.[7]

Troubleshooting Guides

This section provides a systematic approach to troubleshooting common issues leading to a low T-cell response to influenza NP (266-274) stimulation.

Issue 1: Weak or No T-Cell Response in Experimental Wells

A primary concern is observing a minimal or absent response to the NP peptide while the positive control (e.g., PHA or a CEF peptide pool) shows a robust response. This suggests an issue specific to the NP peptide stimulation.

Potential Cause	Recommended Action
Suboptimal Peptide Concentration	Perform a dose-response experiment to determine the optimal concentration of the NP (266-274) peptide. A typical starting concentration is 1-10 µg/mL. [9] [12]
Peptide Degradation	Ensure proper storage of the peptide stock solution (typically at -20°C or -80°C in small aliquots to avoid repeated freeze-thaw cycles). Confirm the peptide's stability and handling instructions from the supplier. [3]
Incorrect HLA Restriction	The NP (266-274) epitope is often presented by specific HLA molecules (e.g., HLA-A*03). [3] [4] If the donor's cells do not express the appropriate HLA type, they will not recognize the peptide. Verify the HLA type of the cell donor if possible.
Low Frequency of Precursor T-Cells	The frequency of T-cells specific for a single epitope can be low in some individuals. Increase the number of cells per well to increase the chances of detecting a response. [6]

Issue 2: High Background in Negative Control Wells

High background can mask a true positive response, making the results difficult to interpret.

Potential Cause	Recommended Action
Cell Culture Contamination	Visually inspect cell cultures for signs of bacterial or fungal contamination. Use sterile techniques and check all reagents for contamination.[6]
Poor Cell Viability	Assess cell viability before and after the assay using methods like trypan blue exclusion or a viability dye for flow cytometry.[10][11] Low viability can lead to non-specific cytokine release.
Serum Reactivity	The serum used in the culture medium may contain factors that non-specifically activate T-cells. Screen different lots of serum or use a serum-free medium.[6]
Over-Stimulation of Cells	Excessive manipulation or harsh processing of cells before the assay can lead to activation. Handle cells gently and minimize processing time.[11]

Issue 3: Inconsistent Results Between Replicates

Poor consistency between replicate wells can undermine the reliability of the data.

Potential Cause	Recommended Action
Pipetting Errors	Ensure accurate and consistent pipetting of cells, peptides, and reagents. Calibrate pipettes regularly.[9]
Uneven Cell Distribution	Thoroughly mix the cell suspension before plating to ensure an equal number of cells are added to each well.
Edge Effects in Plates	The outer wells of a culture plate can be prone to evaporation, affecting cell health and response. Avoid using the outermost wells or ensure proper humidification in the incubator.
Instrument Variability	If using an automated reader (e.g., ELISpot reader), ensure it is properly calibrated and functioning correctly.[9]

Experimental Protocols

Preparation of PBMCs from Whole Blood

- Dilute whole blood 1:1 with phosphate-buffered saline (PBS).
- Carefully layer the diluted blood over a density gradient medium (e.g., Ficoll-Paque).
- Centrifuge at 400 x g for 30 minutes at room temperature with the brake off.
- Carefully aspirate the upper layer containing plasma and platelets.
- Collect the layer of mononuclear cells (the "buffy coat").
- Wash the collected cells twice with PBS.
- Resuspend the cell pellet in complete RPMI medium and perform a cell count and viability assessment.

In Vitro T-Cell Stimulation for ELISpot Assay

- Plate Coating: Coat a 96-well PVDF plate with an anti-cytokine capture antibody (e.g., anti-IFN- γ) overnight at 4°C.
- Blocking: Wash the plate and block with complete RPMI medium for at least 1 hour at 37°C.
- Cell Plating: Add PBMCs to the wells at a concentration of $2-4 \times 10^5$ cells/well.
- Stimulation:
 - Negative Control: Add medium only.
 - Positive Control: Add a mitogen (e.g., PHA) or a control peptide pool (e.g., CEF).
 - Experimental: Add the influenza NP (266-274) peptide at the predetermined optimal concentration.
- Incubation: Incubate the plate for 18-24 hours at 37°C in a 5% CO₂ incubator.
- Detection:
 - Wash the plate to remove cells.
 - Add a biotinylated anti-cytokine detection antibody and incubate for 2 hours at room temperature.
 - Wash and add streptavidin-alkaline phosphatase (ALP) and incubate for 1 hour.
 - Wash and add the substrate (e.g., BCIP/NBT) to develop the spots.
- Analysis: Stop the development by washing with water. Allow the plate to dry and count the spots using an ELISpot reader.

Visualizations

T-Cell Activation Signaling Pathway

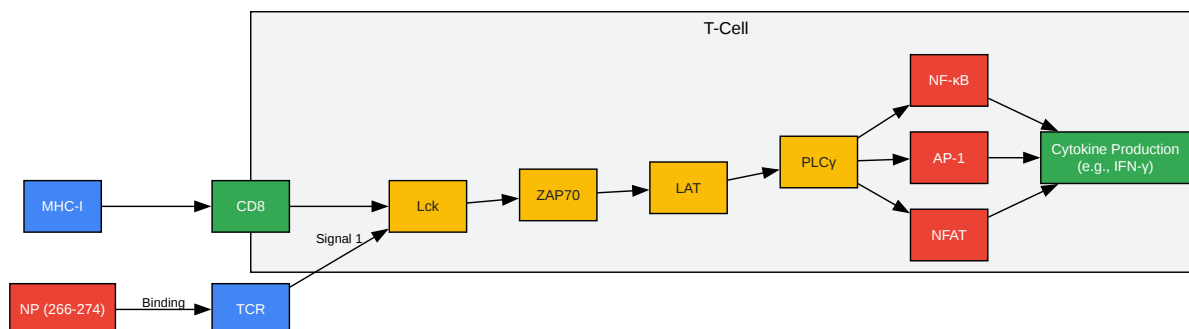

[Click to download full resolution via product page](#)

Caption: Simplified signaling pathway of T-cell activation by the influenza NP peptide.

Experimental Workflow for T-Cell Assays

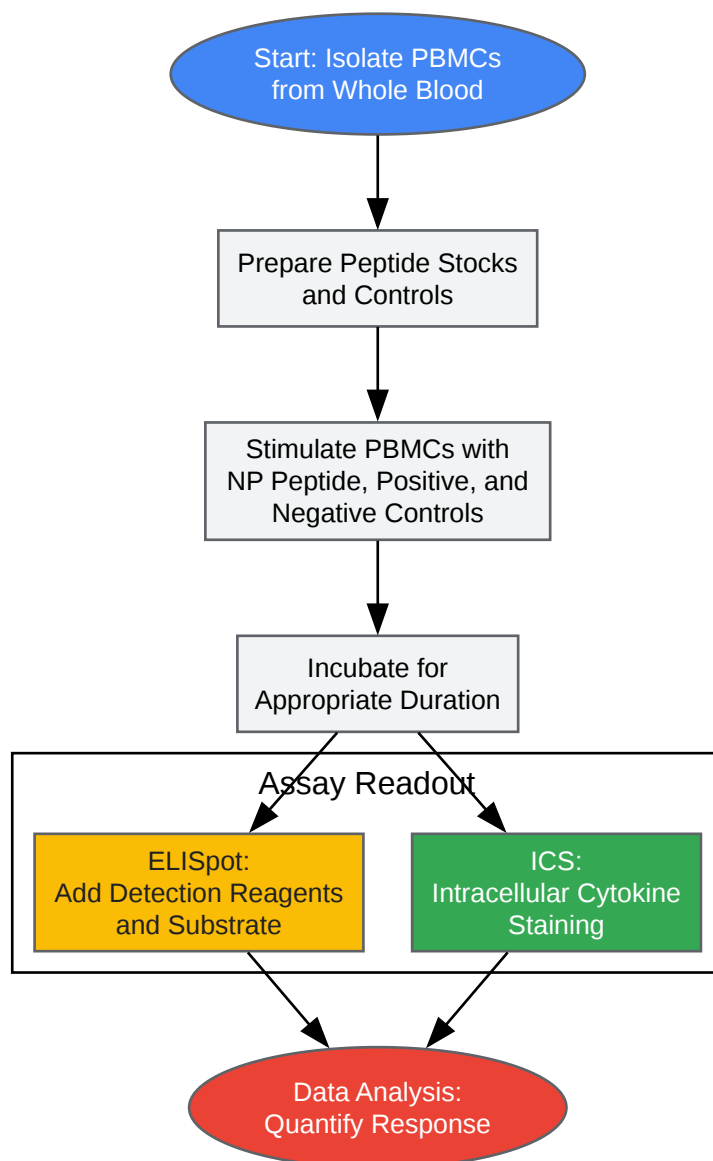

[Click to download full resolution via product page](#)

Caption: General experimental workflow for measuring T-cell responses.

Troubleshooting Logic Diagram

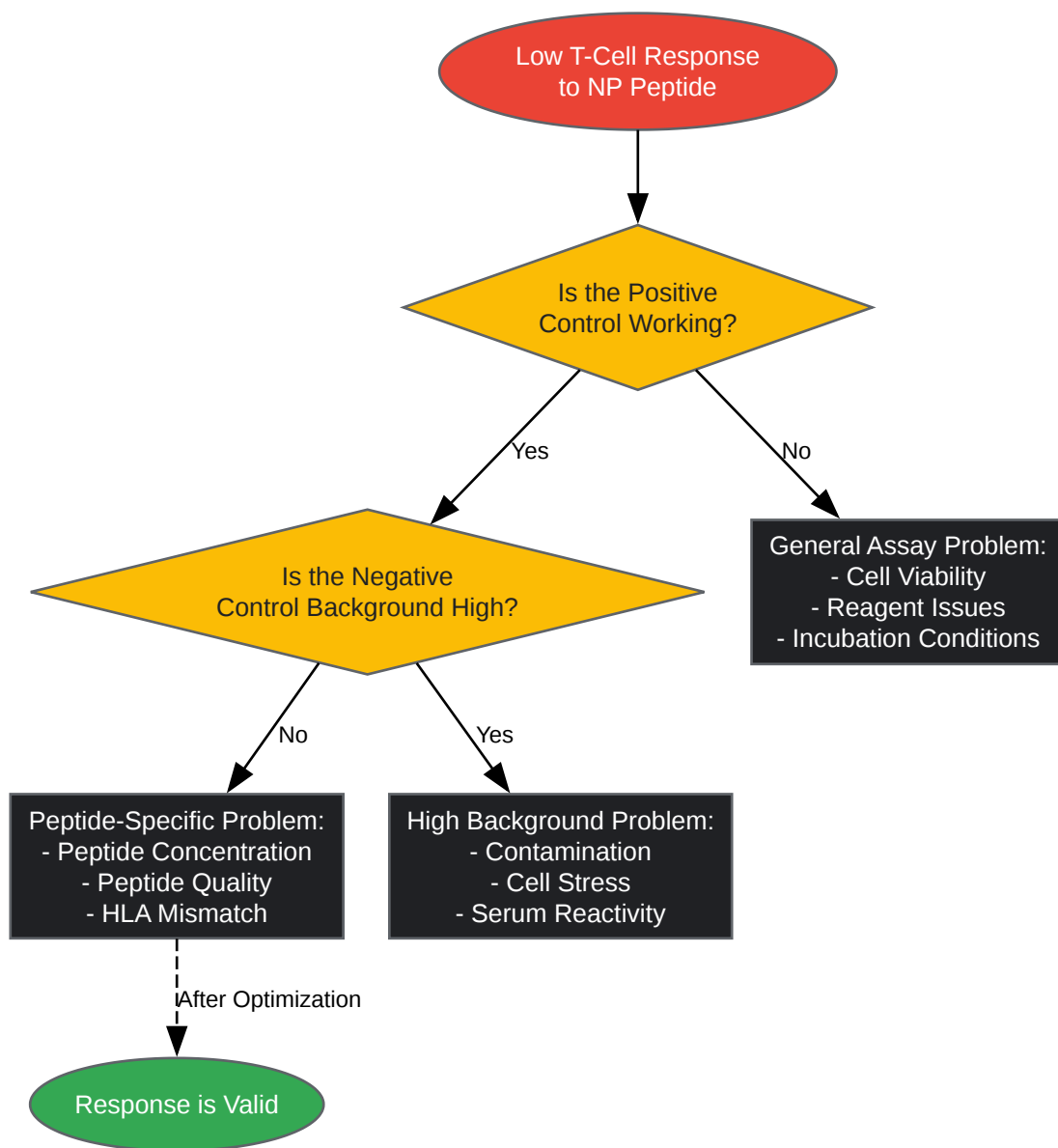

[Click to download full resolution via product page](#)

Caption: A logical flow for troubleshooting low T-cell responses.

Need Custom Synthesis?

BenchChem offers custom synthesis for rare earth carbides and specific isotopic labeling.

Email: info@benchchem.com or [Request Quote Online](#).

References

- [1. journals.asm.org \[journals.asm.org\]](https://journals.asm.org)
- [2. journals.asm.org \[journals.asm.org\]](https://journals.asm.org)
- [3. medchemexpress.com \[medchemexpress.com\]](https://medchemexpress.com)
- [4. file.medchemexpress.eu \[file.medchemexpress.eu\]](https://file.medchemexpress.eu)
- [5. Epitope specific T-cell responses against influenza A in a healthy population - PMC \[pmc.ncbi.nlm.nih.gov\]](https://pubmed.ncbi.nlm.nih.gov/36111111/)
- [6. Troubleshooting T cell ELISPOT assay | U-CyTech \[ucytech.com\]](https://www.ncyte.com)
- [7. ELISpot vs. ICS: Optimizing Immune Monitoring in Clinical Trials with the Right Functional Assay | CellCarta \[cellcarta.com\]](https://www.cellcarta.com)
- [8. mdpi.com \[mdpi.com\]](https://www.mdpi.com)
- [9. benchchem.com \[benchchem.com\]](https://www.benchchem.com)
- [10. Impact of shipping temperature on cell viability and T cell responses to bacterial antigens - PubMed \[pubmed.ncbi.nlm.nih.gov\]](https://pubmed.ncbi.nlm.nih.gov/36111111/)
- [11. researchgate.net \[researchgate.net\]](https://www.researchgate.net)
- [12. Overlapping peptides elicit distinct CD8+ T cell responses following influenza A virus infection - PMC \[pmc.ncbi.nlm.nih.gov\]](https://pubmed.ncbi.nlm.nih.gov/36111111/)
- To cite this document: BenchChem. [Technical Support Center: Influenza NP (266-274) T-Cell Stimulation]. BenchChem, [2026]. [Online PDF]. Available at: [<https://www.benchchem.com/product/b12391109/docs#technical-support-center-influenza-np-266-274-t-cell-stimulation>]

Disclaimer & Data Validity:

The information provided in this document is for Research Use Only (RUO) and is strictly not intended for diagnostic or therapeutic procedures. While BenchChem strives to provide accurate protocols, we make no warranties, express or implied, regarding the fitness of this product for every specific experimental setup.

Technical Support: The protocols provided are for reference purposes. Unsure if this reagent suits your experiment?

Need Industrial/Bulk Grade? [Request Custom Synthesis Quote](#)

BenchChem

Our mission is to be the trusted global source of essential and advanced chemicals, empowering scientists and researchers to drive progress in science and industry.

Contact

Address: 3281 E Guasti Rd

Ontario, CA 91761, United States

Phone: (601) 213-4426

Email: info@benchchem.com

[Contact our Ph.D. Support Team for a compatibility check](#)