

Comparative Guide to Quantitative PCR for Confirming JAK2 Knockdown

Author: BenchChem Technical Support Team. **Date:** April 2026

Compound of Interest

Compound Name: SJ1008030 TFA

Cat. No.: B12391202

[Get Quote](#)

A Guide for Researchers, Scientists, and Drug Development Professionals

Introduction

This guide provides a comprehensive comparison and detailed experimental protocols for utilizing quantitative Polymerase Chain Reaction (qPCR) to confirm the knockdown of Janus Kinase 2 (JAK2). Given the absence of public data on a compound named "**SJ1008030 TFA**," this document uses Fedratinib, an FDA-approved selective JAK2 inhibitor, as a representative compound to illustrate the experimental workflow and data analysis.[1][2] The principles and methods described herein are broadly applicable for validating the efficacy of novel inhibitors targeting JAK2.

The JAK-STAT signaling pathway is a critical chain of protein interactions within cells, involved in processes like immunity, cell division, and apoptosis.[3] It relays information from external chemical signals to the cell nucleus, leading to the activation of gene transcription.[3] The three main components of this pathway are Janus kinases (JAKs), Signal Transducer and Activator of Transcription (STAT) proteins, and receptors that bind to the chemical signals.[3] Dysregulation of the JAK-STAT pathway is implicated in various diseases, including myeloproliferative neoplasms (MPNs) and other cancers.[4][5] The JAK2 V617F mutation, for

instance, leads to the overactivation of the JAK2 kinase, causing excessive blood cell production.[6]

The JAK-STAT Signaling Pathway

The binding of a ligand, such as a cytokine or growth factor, to a cell-surface receptor triggers the activation of associated JAKs.[4][7] Activated JAKs then phosphorylate the receptor, creating docking sites for STAT proteins.[7] Subsequently, JAKs phosphorylate the STATs, which then form dimers, translocate to the nucleus, and bind to specific DNA sequences to regulate gene transcription.[4][8]

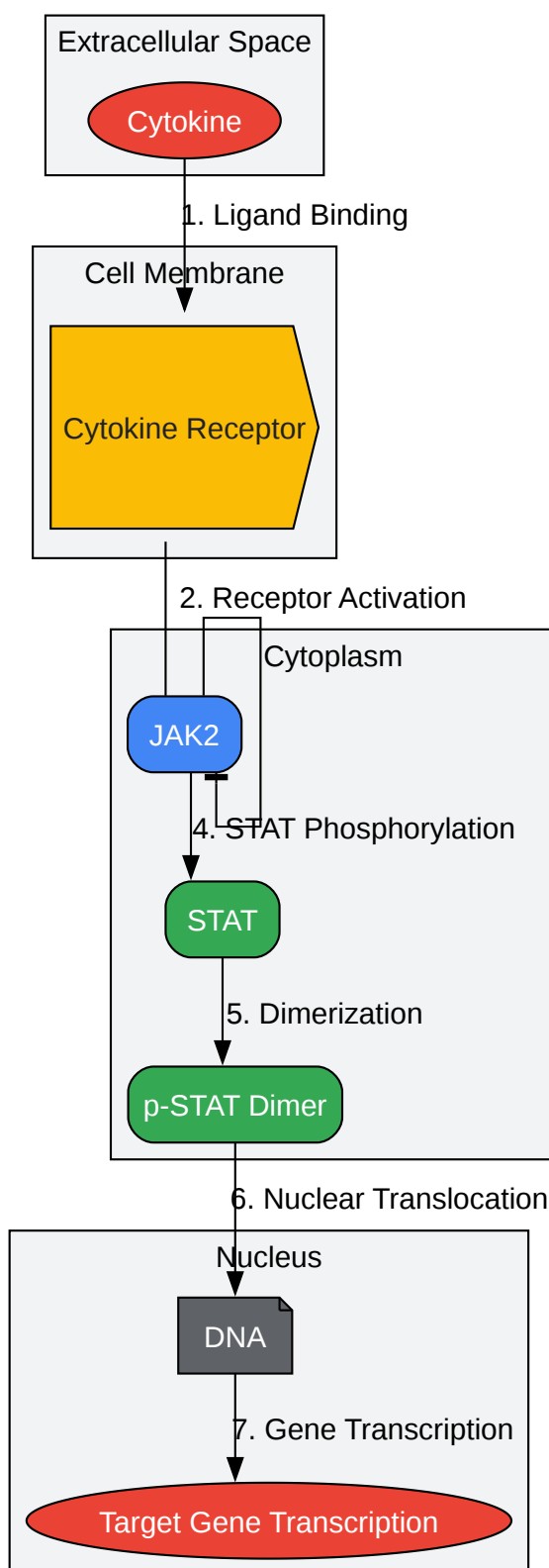

[Click to download full resolution via product page](#)

A diagram of the JAK-STAT signaling pathway.

Comparative Analysis of JAK2 Inhibitors

Several small molecule inhibitors targeting JAK2 have been developed for therapeutic use. While they share the common mechanism of suppressing JAK-STAT signaling, they exhibit different potency and ancillary effects.[9]

Inhibitor	Target(s)	Reported IC50 (JAK2)	Key Characteristics
Fedratinib	JAK2-selective	~3 nM	Approved for myelofibrosis, effective in both treatment-naïve and previously treated patients.[1][2]
Ruxolitinib	JAK1/JAK2	~3.3 nM (JAK1), ~2.8 nM (JAK2)	First JAK inhibitor approved for myelofibrosis, also used for polycythemia vera.[10][11] Can lead to paradoxical JAK2 hyperphosphorylation. [12]
Pacritinib	JAK2/FLT3	~23 nM	Demonstrates potent suppression of colony formation in primary samples.[9]
Momelotinib	JAK1/JAK2	~11 nM (JAK1), ~18 nM (JAK2)	Exhibits a unique sparing of erythroid colony formation.[9]

Note: IC50 values can vary depending on the specific assay conditions and cell lines used.

Experimental Protocol: qPCR for JAK2 Knockdown Confirmation

This protocol outlines the steps to quantify the reduction in JAK2 mRNA levels in a human cell line following treatment with a JAK2 inhibitor.[13][14]

1. Cell Culture and Treatment

- Cell Line Selection: Utilize a human cell line with a known JAK2 mutation, such as HEL (harboring JAK2 V617F), UKE-1, or SET-2 cells.[9][15]
- Culture Conditions: Culture the cells in appropriate media and conditions as recommended by the supplier.
- Inhibitor Treatment:
 - Seed the cells at a suitable density in multi-well plates.
 - Treat the cells with the JAK2 inhibitor (e.g., Fedratinib) at various concentrations (e.g., 0, 50, 100, 250, 500, and 1,000 nmol/L).[16]
 - Include a vehicle control (e.g., DMSO) and an untreated control.
 - Incubate for a predetermined time (e.g., 24-48 hours) to allow for mRNA turnover.[17]

2. RNA Extraction

- Harvest the cells from each treatment condition.
- Isolate total RNA using a commercial kit (e.g., RNeasy Mini Kit) according to the manufacturer's protocol.[14]
- Assess the quantity and quality of the extracted RNA using a spectrophotometer (e.g., NanoDrop) or a fluorometer (e.g., Qubit).

3. cDNA Synthesis (Reverse Transcription)

- Synthesize complementary DNA (cDNA) from the total RNA using a reverse transcription kit.

- This step converts the RNA into a more stable DNA template for qPCR.[13]

4. Quantitative PCR (qPCR)

- Reaction Setup: Prepare the qPCR reaction mixture containing:
 - cDNA template
 - qPCR master mix (containing Taq polymerase, dNTPs, and a fluorescent dye like SYBR Green or a probe)[14]
 - Forward and reverse primers for JAK2
 - Forward and reverse primers for a housekeeping gene (e.g., GAPDH, ACTB) for normalization[14]
- Primer Design: Use validated primers specific for the target gene (JAK2) and the reference gene.
- Thermal Cycling: Perform the qPCR on a real-time PCR instrument with appropriate cycling conditions (e.g., initial denaturation, followed by 40-50 cycles of denaturation, annealing, and extension).[18][19][20]

5. Data Analysis

- Quantification Cycle (Cq): Determine the Cq (or Ct) value for both JAK2 and the housekeeping gene in each sample. The Cq is the cycle number at which the fluorescence signal crosses a certain threshold.
- Relative Quantification ($\Delta\Delta Cq$ Method):
 - Normalization: Calculate the ΔCq for each sample by subtracting the Cq of the housekeeping gene from the Cq of JAK2 ($\Delta Cq = Cq(\text{JAK2}) - Cq(\text{housekeeping})$).[17]
 - Calibration: Calculate the $\Delta\Delta Cq$ by subtracting the ΔCq of the control group (e.g., vehicle-treated) from the ΔCq of the treated group ($\Delta\Delta Cq = \Delta Cq(\text{treated}) - \Delta Cq(\text{control})$).[17]
 - Determine Fold Change: The fold change in gene expression is calculated as $2^{-\Delta\Delta Cq}$.[17]

- **Statistical Analysis:** Perform statistical analysis to determine the significance of the observed knockdown.

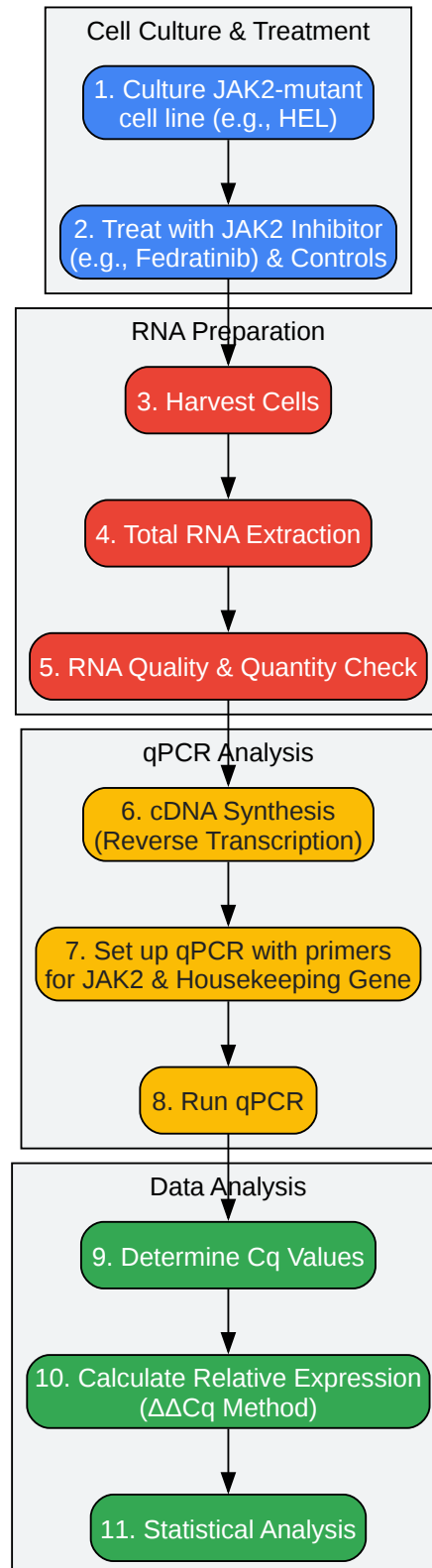

[Click to download full resolution via product page](#)

An overview of the qPCR workflow for JAK2 knockdown analysis.

Conclusion

Quantitative PCR is a robust and sensitive method for confirming the knockdown of JAK2 at the mRNA level. By following a well-defined protocol and using appropriate controls, researchers can accurately quantify the efficacy of JAK2 inhibitors like Fedratinib. This data is crucial for the preclinical validation of novel therapeutic compounds and for understanding their mechanism of action. The comparative data provided serves as a benchmark for evaluating the performance of new chemical entities targeting the JAK-STAT pathway.

Need Custom Synthesis?

BenchChem offers custom synthesis for rare earth carbides and specific isotopic labeling.

Email: info@benchchem.com or [Request Quote Online](#).

References

- [1. Fedratinib, the first selective JAK2 inhibitor approved for treatment of myelofibrosis - an option beyond ruxolitinib - PubMed \[pubmed.ncbi.nlm.nih.gov\]](#)
- [2. Safety and efficacy of fedratinib, a selective oral inhibitor of Janus kinase-2 \(JAK2\), in patients with myelofibrosis and low pretreatment platelet counts - PubMed \[pubmed.ncbi.nlm.nih.gov\]](#)
- [3. JAK-STAT signaling pathway - Wikipedia \[en.wikipedia.org\]](#)
- [4. The JAK/STAT Pathway - PMC \[pmc.ncbi.nlm.nih.gov\]](#)
- [5. Frontiers | JAK/STAT pathway: Extracellular signals, diseases, immunity, and therapeutic regimens \[frontiersin.org\]](#)
- [6. signosisinc.com \[signosisinc.com\]](#)
- [7. journals.biologists.com \[journals.biologists.com\]](#)
- [8. m.youtube.com \[m.youtube.com\]](#)
- [9. Comprehensive profiling of clinical JAK inhibitors in myeloproliferative neoplasms - PMC \[pmc.ncbi.nlm.nih.gov\]](#)

- 10. Impact of Ruxolitinib Interactions on JAK2 JH1 Domain Dynamics - PubMed [pubmed.ncbi.nlm.nih.gov]
- 11. Impact of Ruxolitinib Interactions on JAK2 JH1 Domain Dynamics [[mdpi.com](https://www.mdpi.com)]
- 12. Ruxolitinib mediated paradoxical JAK2 hyperphosphorylation is due to the protection of activation loop tyrosines from phosphatases - PMC [pubmed.ncbi.nlm.nih.gov]
- 13. Measuring RNAi knockdown using qPCR - PubMed [pubmed.ncbi.nlm.nih.gov]
- 14. qiagen.com [[qiagen.com](https://www.qiagen.com)]
- 15. Validate User [[ashpublications.org](https://www.ashpublications.org)]
- 16. Effects of Ruxolitinib on Immune Checkpoint Molecule Expression in JAK2 V617F-Positive Cells - PubMed [pubmed.ncbi.nlm.nih.gov]
- 17. Hallmarks of good RT-qPCR measurements in a successful knockdown experiment [[horizondiscovery.com](https://www.horizondiscovery.com)]
- 18. Design and Evaluation of a Real-Time PCR Assay for Quantification of JAK2 V617F and Wild-Type JAK2 Transcript Levels in the Clinical Laboratory - PMC [pubmed.ncbi.nlm.nih.gov]
- 19. Development of a Quantitative Real-Time Polymerase Chain Reaction Assay for the Detection of the JAK2 V617F Mutation - PMC [pubmed.ncbi.nlm.nih.gov]
- 20. Quantitative Determination of JAK2 V617F by TaqMan: An Absolute Measure of Averaged Copies per Cell That May Be Associated with the Different Types of Myeloproliferative Disorders - PMC [pubmed.ncbi.nlm.nih.gov]
- To cite this document: BenchChem. [Comparative Guide to Quantitative PCR for Confirming JAK2 Knockdown]. BenchChem, [2026]. [Online PDF]. Available at: [<https://www.benchchem.com/product/b12391202/docs#comparative-guide-to-quantitative-pcr-for-confirming-jak2-knockdown>]

Disclaimer & Data Validity:

The information provided in this document is for Research Use Only (RUO) and is strictly not intended for diagnostic or therapeutic procedures. While BenchChem strives to provide accurate protocols, we make no warranties, express or implied, regarding the fitness of this product for every specific experimental setup.

Technical Support: The protocols provided are for reference purposes. Unsure if this reagent suits your experiment?

Need Industrial/Bulk Grade? [Request Custom Synthesis Quote](#)

BenchChem

Our mission is to be the trusted global source of essential and advanced chemicals, empowering scientists and researchers to drive progress in science and industry.

Contact

Address: 3281 E Guasti Rd
Ontario, CA 91761, United States
Phone: (601) 213-4426
Email: info@benchchem.com

[Contact our Ph.D. Support Team for a compatibility check](#)