

An In-depth Technical Guide to Influenza NP (266-274) Epitope Mapping Studies

Author: BenchChem Technical Support Team. **Date:** April 2026

Compound of Interest

Compound Name: *Influenza virus NP (266-274)*

Cat. No.: *B12391109*

[Get Quote](#)

For Researchers, Scientists, and Drug Development Professionals

This technical guide provides a comprehensive overview of the methodologies and quantitative data associated with the mapping of the influenza nucleoprotein (NP) epitope spanning amino acids 266-274. This epitope, with the sequence Ile-Leu-Arg-Gly-Ser-Val-Ala-His-Lys (ILRGSAHK), is a known target for cytotoxic T lymphocytes (CTLs) and is restricted by the human leukocyte antigen (HLA)-A*03 allele. Understanding the immunological characteristics of this epitope is crucial for the development of novel influenza vaccines and T-cell-based therapeutics.

Core Concepts in Epitope Mapping

Epitope mapping is the process of identifying the specific amino acid residues of an antigen that are recognized by the immune system, particularly by antibodies and T-cell receptors. For T-cell epitopes, this involves the recognition of a peptide fragment of the antigen presented by Major Histocompatibility Complex (MHC) molecules on the surface of antigen-presenting cells (APCs) or infected cells. The Influenza NP (266-274) epitope is a linear epitope, meaning it is defined by a continuous sequence of amino acids.

Quantitative Data Summary

The following tables summarize key quantitative data from studies investigating the Influenza NP (265-273) epitope, which is homologous to the 266-274 region. This data provides insights into the immunogenicity and MHC binding characteristics of this important T-cell target.

Table 1: T-Cell Response to Influenza NP (265-273) Epitope

Assay Type	Cell Type	Stimulus	Result	Donor Information
IFN- γ ELISpot	Peripheral Blood Mononuclear Cells (PBMCs)	NP (265-273) peptide	12 spots per 2.5 x 10 ⁵ PBMCs	HLA-A3 positive donor (Donor 12) [1]
IFN- γ ELISpot	In vitro-expanded CTLs	NP (265-273) peptide	Average of 45 IFN- γ + cells per 15,000 effector cells	Group of 18 HLA-typed individuals[2]

Table 2: Cytotoxicity Mediated by NP (265-273)-Specific CTLs

Target Cells	Effector Cells	Effector to Target Ratio (E:T)	% Specific Lysis	Notes
Peptide-sensitized B-LCL	HLA-A3-restricted influenza-immune CTL	Not specified	Capable of sensitizing for lysis	Indicates the peptide is processed and presented.[3]
rNP-incubated B-LCL	NP/A3 CTL	10:1	Lysis observed at rNP concentrations \geq 50 μ M	Demonstrates recognition of endogenously processed antigen.[4]

Table 3: MHC Class I Binding of Influenza NP (265-273) Peptide

MHC Allele	Assay Type	Peptide Sequence	Binding Capacity
HLA-A3	In vitro peptide binding assay	ILRGSVAHK	Positive
HLA-A3	Flow cytometry-based monomer binding assay	ILRGSVAHK	Positive Control Binder

Experimental Protocols

Detailed methodologies are essential for the replication and advancement of epitope mapping studies. Below are protocols for key experiments cited in the quantitative data summary.

Protocol 1: IFN- γ ELISpot Assay for T-Cell Response

This protocol is a standard method for quantifying the frequency of cytokine-secreting T cells at the single-cell level.

Materials:

- 96-well PVDF membrane ELISpot plates
- Anti-human IFN- γ capture antibody
- Biotinylated anti-human IFN- γ detection antibody
- Streptavidin-Alkaline Phosphatase (ALP)
- BCIP/NBT substrate
- RPMI 1640 medium supplemented with 10% fetal bovine serum (FBS)
- Influenza NP (265-273) peptide (ILRGSVAHK)
- Peripheral Blood Mononuclear Cells (PBMCs) from an HLA-A3 positive donor

Procedure:

- Plate Coating: Coat the ELISpot plate wells with anti-human IFN- γ capture antibody overnight at 4°C.
- Blocking: Wash the wells and block with RPMI/10% FBS for 2 hours at 37°C.
- Cell Plating: Add 2.5×10^5 PBMCs to each well.
- Peptide Stimulation: Add the NP (265-273) peptide to the designated wells at a final concentration of 10 $\mu\text{g}/\text{mL}$. Include a negative control (no peptide) and a positive control (e.g., PHA).
- Incubation: Incubate the plate for 18-24 hours at 37°C in a 5% CO₂ incubator.
- Detection: Wash the wells and add the biotinylated anti-human IFN- γ detection antibody. Incubate for 2 hours at room temperature.
- Enzyme Conjugation: Wash the wells and add Streptavidin-ALP. Incubate for 1 hour at room temperature.
- Development: Wash the wells and add BCIP/NBT substrate. Monitor for spot development.
- Analysis: Stop the reaction by washing with water. Allow the plate to dry and count the spots using an ELISpot reader. Each spot represents a single IFN- γ secreting cell.

Protocol 2: Chromium (51Cr) Release Assay for Cytotoxicity

This assay measures the ability of cytotoxic T lymphocytes (CTLs) to lyse target cells presenting the specific epitope.

Materials:

- Target cells (e.g., HLA-A3 positive B-lymphoblastoid cell line - B-LCL)
- Effector cells (CTLs specific for NP 265-273)
- Influenza NP (265-273) peptide

- Sodium Chromate (51Cr)
- RPMI 1640 medium with 10% FBS
- 96-well U-bottom plates
- Gamma counter

Procedure:

- Target Cell Labeling: Label the target B-LCL cells with 51Cr for 1 hour at 37°C.
- Peptide Pulsing: Wash the labeled target cells and pulse them with the NP (265-273) peptide (10 µg/mL) for 1 hour at 37°C.
- Cell Plating: Plate the peptide-pulsed target cells in a 96-well plate.
- Effector Cell Addition: Add the effector CTLs at various effector-to-target (E:T) ratios.
- Controls:
 - Spontaneous release: Target cells with medium only.
 - Maximum release: Target cells with a detergent (e.g., Triton X-100).
- Incubation: Incubate the plate for 4-6 hours at 37°C.
- Supernatant Collection: Centrifuge the plate and collect the supernatant.
- Counting: Measure the radioactivity (counts per minute - CPM) in the supernatant using a gamma counter.
- Calculation of Specific Lysis:
 - % Specific Lysis = $[(\text{Experimental Release} - \text{Spontaneous Release}) / (\text{Maximum Release} - \text{Spontaneous Release})] \times 100$

Protocol 3: In Vitro Peptide-MHC Binding Assay

This assay determines the ability of a peptide to bind to a specific MHC molecule.

Materials:

- Purified, soluble HLA-A3 molecules
- A known high-affinity HLA-A3 binding peptide labeled with a fluorescent or radioactive tag (reference peptide)
- Influenza NP (265-273) peptide (test peptide)
- Assay buffer (e.g., PBS with a protease inhibitor)
- Method for separating bound from free peptide (e.g., gel filtration, ELISA-based format)

Procedure (ELISA-based example):

- Plate Coating: Coat a 96-well plate with an anti-HLA-A3 antibody.
- MHC Capture: Add purified HLA-A3 molecules to the wells and incubate to allow capture.
- Competitive Binding: Prepare a mixture of the labeled reference peptide at a fixed concentration and varying concentrations of the unlabeled NP (265-273) test peptide.
- Incubation: Add the peptide mixtures to the HLA-A3 coated wells and incubate to allow binding to reach equilibrium.
- Washing: Wash the wells to remove unbound peptides.
- Detection: Measure the amount of bound labeled reference peptide using a suitable plate reader.
- Analysis: The ability of the NP (265-273) peptide to inhibit the binding of the labeled reference peptide is used to determine its binding affinity, often expressed as an IC₅₀ value (the concentration of test peptide required to inhibit 50% of the reference peptide binding).

Visualizations of Experimental Workflows and Signaling Pathways

To further elucidate the processes involved in Influenza NP (266-274) epitope mapping, the following diagrams, generated using Graphviz (DOT language), illustrate key experimental workflows and the fundamental T-cell receptor signaling pathway.

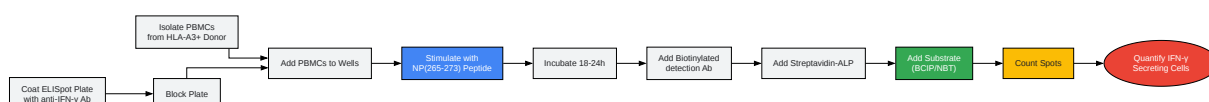

[Click to download full resolution via product page](#)

IFN- γ ELISpot Assay Workflow



[Click to download full resolution via product page](#)

Chromium Release Cytotoxicity Assay Workflow

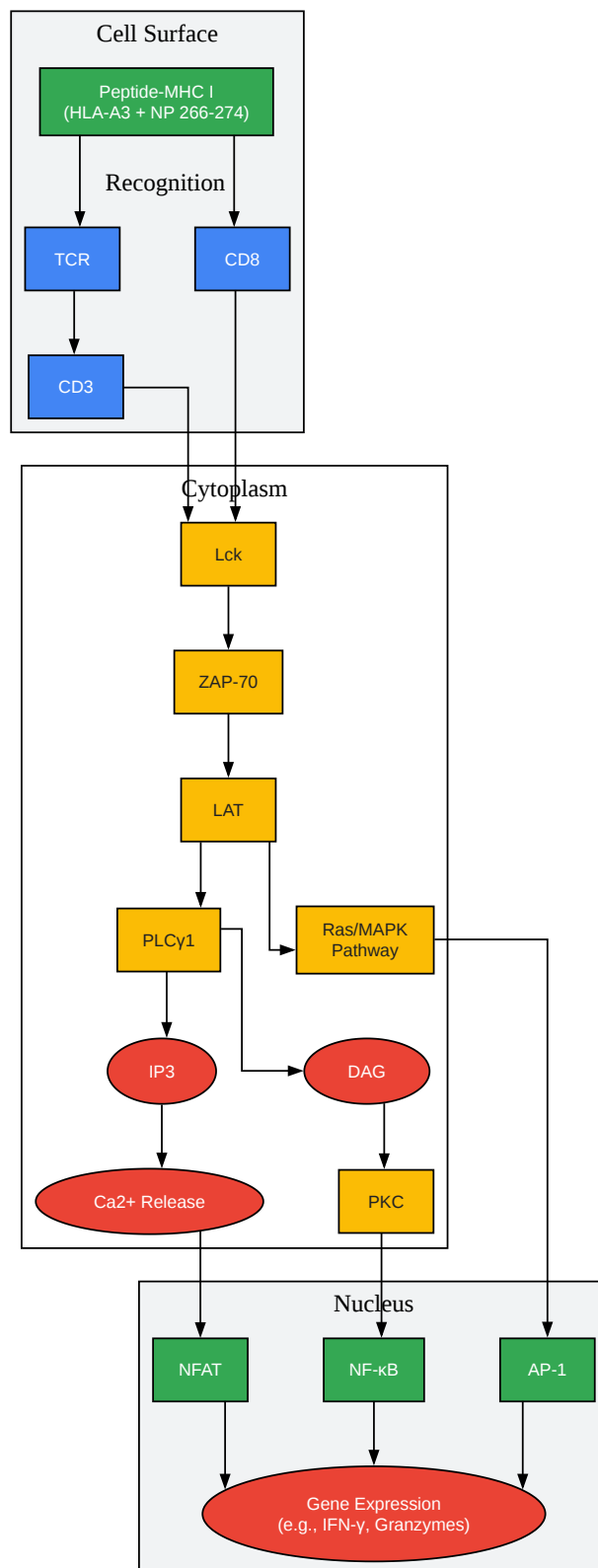

[Click to download full resolution via product page](#)

T-Cell Receptor Signaling Pathway

This guide serves as a foundational resource for professionals engaged in influenza research and vaccine development. The provided data, protocols, and visualizations offer a detailed perspective on the immunological significance of the NP (266-274) epitope and the experimental approaches used to characterize it. Further investigation into the diversity of T-cell responses and the impact of viral evolution on this epitope will continue to be critical areas of study.

Need Custom Synthesis?

BenchChem offers custom synthesis for rare earth carbides and specific isotopic labeling.

Email: info@benchchem.com or [Request Quote Online](#).

References

- [1. The Magnitude and Specificity of Influenza A Virus-Specific Cytotoxic T-Lymphocyte Responses in Humans Is Related to HLA-A and -B Phenotype - PMC \[pmc.ncbi.nlm.nih.gov\]](#)
- [2. The Hypervariable Immunodominant NP418-426 Epitope from the Influenza A Virus Nucleoprotein Is Recognized by Cytotoxic T Lymphocytes with High Functional Avidity - PMC \[pmc.ncbi.nlm.nih.gov\]](#)
- [3. mstechno.co.jp \[mstechno.co.jp\]](#)
- [4. Antigen processing for MHC class I restricted presentation of exogenous influenza A virus nucleoprotein by B-lymphoblastoid cells - PMC \[pmc.ncbi.nlm.nih.gov\]](#)
- To cite this document: BenchChem. [An In-depth Technical Guide to Influenza NP (266-274) Epitope Mapping Studies]. BenchChem, [2026]. [Online PDF]. Available at: [\[https://www.benchchem.com/product/b12391109/docs#an-in-depth-technical-guide-to-influenza-np-266-274-epitope-mapping-studies\]](https://www.benchchem.com/product/b12391109/docs#an-in-depth-technical-guide-to-influenza-np-266-274-epitope-mapping-studies)

Disclaimer & Data Validity:

The information provided in this document is for Research Use Only (RUO) and is strictly not intended for diagnostic or therapeutic procedures. While BenchChem strives to provide accurate protocols, we make no warranties, express or implied, regarding the fitness of this product for every specific experimental setup.

Technical Support: The protocols provided are for reference purposes. Unsure if this reagent suits your experiment?

Need Industrial/Bulk Grade? [Request Custom Synthesis Quote](#)

BenchChem

Our mission is to be the trusted global source of essential and advanced chemicals, empowering scientists and researchers to drive progress in science and industry.

Contact

Address: 3281 E Guasti Rd

Ontario, CA 91761, United States

Phone: (601) 213-4426

Email: info@benchchem.com

[Contact our Ph.D. Support Team for a compatibility check](#)