

A Technical Guide to the Role of Complement Component C3 in Neuroscience Research

Author: BenchChem Technical Support Team. **Date:** April 2026

Compound of Interest

Compound Name: NerveGreen C3

Cat. No.: B12391384

[Get Quote](#)

Disclaimer: This technical guide focuses on the applications and research pertaining to the complement component C3 and its signaling pathways in neuroscience. No specific information was found for a product or entity named "**NerveGreen C3**." The following content is based on available research on the complement C3 protein and its role in the central nervous system.

Introduction

The complement system, a cornerstone of innate immunity, is increasingly recognized for its critical roles in the central nervous system (CNS) in both health and disease. At the heart of this system lies complement component 3 (C3), a protein that serves as a central hub for all three complement activation pathways. Recent research has illuminated the involvement of C3 and its downstream signaling in the pathogenesis of various neurological and retinal disorders. This guide provides an in-depth overview of the applications of studying the C3 pathway in neuroscience research, with a focus on experimental methodologies and data interpretation for researchers, scientists, and professionals in drug development.

The Complement C3/C3aR Signaling Pathway

The complement cascade can be initiated through the classical, alternative, or lectin pathways, all of which converge on the cleavage of C3 into its active fragments, C3a and C3b[1][2]. The

smaller fragment, C3a, is a potent anaphylatoxin that mediates inflammatory responses by binding to its receptor, C3aR[2]. The larger fragment, C3b, acts as an opsonin, tagging pathogens and cellular debris for phagocytosis, and participates in the formation of the C5 convertase, which propagates the complement cascade[2].

The C3/C3aR signaling pathway is implicated in a range of cellular responses in the CNS, including microglial activation, neuroinflammation, and neuronal damage[3]. In pathological conditions such as neuromyelitis optica spectrum disorders (NMOSD) and retinal vein occlusion (RVO), upregulation of C3 and C3aR has been observed, correlating with disease severity.

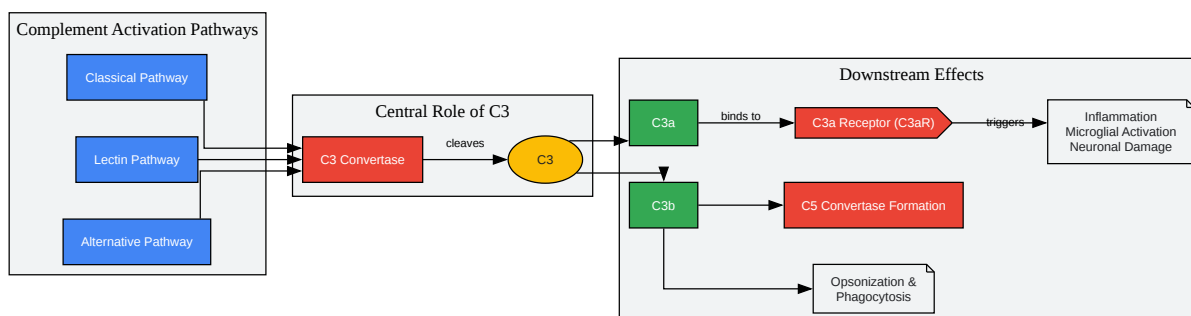

[Click to download full resolution via product page](#)

Figure 1: The Complement C3 Signaling Pathway.

Quantitative Data from Preclinical Studies

The following tables summarize quantitative findings from studies investigating the C3 pathway in models of neurological and retinal diseases.

Table 1: Retinal Thickness and Detachment in Experimental Retinal Vein Occlusion (RVO)

Parameter	Control (n=4)	RVO + Vehicle (n=14)	RVO + C3aR Antagonist (n=13)
Total Retinal Thickness (µm)			
Day 1	198.5 ± 2.5	280.1 ± 8.2	235.6 ± 7.1**
Day 2	197.9 ± 3.1	265.4 ± 9.5	220.3 ± 6.8*
Day 8	199.2 ± 2.8	210.7 ± 5.3	205.1 ± 4.9
Serous Retinal Detachment Height (µm)			
Day 1	0	75.3 ± 6.4	40.1 ± 5.2***
Day 2	0	60.8 ± 5.9	30.7 ± 4.7**
Day 8	0	15.2 ± 3.1	8.9 ± 2.5

*Data presented as mean ± SEM. *P < 0.05, **P < 0.01, ***P < 0.001 compared to RVO + Vehicle. Data adapted from a study on experimental RVO.

Table 2: Gene Expression of C3 and C3aR in RVO

Gene	Treatment Group	Relative mRNA Expression (Fold Change)
C3	RVO + Vehicle	4.5 ± 0.6
	RVO + C3aR Antagonist	2.1 ± 0.4*
C3aR	RVO + Vehicle	3.8 ± 0.5
	RVO + C3aR Antagonist	1.9 ± 0.3*

*Data presented as mean ± SEM. P < 0.05 compared to RVO + Vehicle. Data adapted from a study on experimental RVO.

Experimental Protocols

This protocol describes the laser-induced RVO model in mice to study the role of the C3/C3aR pathway.

- Animals: Adult C57BL/6J mice.
- Anesthesia: Intraperitoneal injection of a ketamine/xylazine cocktail.
- Pupil Dilation: Topical application of 1% tropicamide and 2.5% phenylephrine.
- Laser Photocoagulation:
 - A coverslip is placed on the cornea with a drop of 0.9% saline.
 - The major retinal vein is identified using a fundus camera.
 - A 532 nm diode laser is used to deliver a single pulse (50 μ m spot size, 100 ms duration, 150-200 mW power) to the vein, approximately one disc diameter from the optic nerve head.
 - Successful occlusion is confirmed by the development of venous dilation and retinal hemorrhage.
- Post-Procedure: Animals are monitored for recovery and administered analgesics.

This protocol details the local delivery of a C3aR inhibitor to the eye.

- Reagent: SB290157 trifluoroacetate (a specific C3aR antagonist).
- Preparation: The antagonist is dissolved in a vehicle (e.g., sterile saline or PBS).
- Procedure:
 - Animals are anesthetized as described above.
 - A small puncture is made through the sclera posterior to the limbus using a 30-gauge needle.

- A Hamilton syringe with a 33-gauge needle is used to inject 1 μ L of the antagonist solution into the vitreous cavity.
- The needle is held in place for 1 minute and then slowly withdrawn.
- Control: The contralateral eye or a separate cohort of animals receives an equal volume of the vehicle.

This protocol outlines the measurement of C3 and C3aR mRNA levels in retinal tissue.

- Tissue Collection: Retinas are dissected from enucleated eyes and immediately placed in a stabilizing solution (e.g., RNAlater).
- RNA Extraction: Total RNA is extracted using a commercial kit (e.g., RNeasy Mini Kit, Qiagen) according to the manufacturer's instructions.
- cDNA Synthesis: First-strand cDNA is synthesized from 1 μ g of total RNA using a reverse transcriptase kit.
- Quantitative PCR (qPCR):
 - qPCR is performed using a real-time PCR system with a SYBR Green-based master mix.
 - Specific primers for C3, C3aR, and a housekeeping gene (e.g., GAPDH) are used.
 - The thermal cycling conditions typically include an initial denaturation step, followed by 40 cycles of denaturation, annealing, and extension.
- Data Analysis: The relative expression of target genes is calculated using the $2^{-\Delta\Delta C_t}$ method, with normalization to the housekeeping gene.

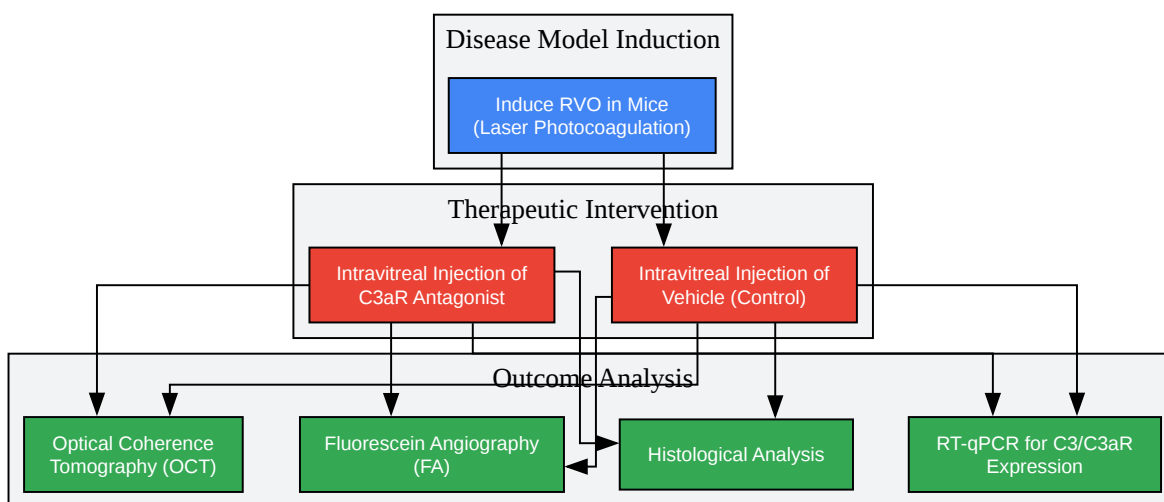

[Click to download full resolution via product page](#)

Need Custom Synthesis?

BenchChem offers custom synthesis for rare earth carbides and specific isotopic labeling.

Email: info@benchchem.com or [Request Quote Online](#).

References

- 1. Inhibition of complement C3 signaling ameliorates locomotor and visual dysfunction in autoimmune inflammatory diseases - PMC [[pmc.ncbi.nlm.nih.gov](https://pubmed.ncbi.nlm.nih.gov/)]
- 2. iovs.arvojournals.org [iovs.arvojournals.org]
- 3. Inhibition of C3/C3aR Pathway Alleviates Visual and Optic Nerve Impairments in a Rat Model of Neuromyelitis Optica Spectrum Disorder - PubMed [pubmed.ncbi.nlm.nih.gov]
- To cite this document: BenchChem. [A Technical Guide to the Role of Complement Component C3 in Neuroscience Research]. BenchChem, [2026]. [Online PDF]. Available at: [<https://www.benchchem.com/product/b12391384/docs#a-technical-guide-to-the-role-of-complement-component-c3-in-neuroscience-research>]

Disclaimer & Data Validity:

The information provided in this document is for Research Use Only (RUO) and is strictly not intended for diagnostic or therapeutic procedures. While BenchChem strives to provide accurate protocols, we make no warranties, express or implied, regarding the fitness of this product for every specific experimental setup.

Technical Support: The protocols provided are for reference purposes. Unsure if this reagent suits your experiment?

Need Industrial/Bulk Grade? [Request Custom Synthesis Quote](#)

BenchChem

Our mission is to be the trusted global source of essential and advanced chemicals, empowering scientists and researchers to drive progress in science and industry.

Contact

Address: 3281 E Guasti Rd
Ontario, CA 91761, United States
Phone: (601) 213-4426
Email: info@benchchem.com

[Contact our Ph.D. Support Team for a compatibility check](#)