

The 8-Position: A Key Determinant in Adenosine Analog Structure-Activity Relationship

Author: BenchChem Technical Support Team. **Date:** April 2026

Compound of Interest

Compound Name: 8-Methoxyadenosine

Cat. No.: B12390488

[Get Quote](#)

An In-depth Technical Guide for Researchers, Scientists, and Drug Development Professionals

The C8 position of the purine core of adenosine has emerged as a critical site for modification, profoundly influencing the affinity and selectivity of its analogs for the four adenosine receptor subtypes (A₁, A_{2A}, A_{2B}, and A₃). Strategic substitution at this position can fine-tune the pharmacological profile of these compounds, offering a pathway to develop potent and selective agonists for therapeutic applications. This guide provides a comprehensive overview of the structure-activity relationship (SAR) of 8-position adenosine analogs, detailing quantitative data, experimental protocols, and visualizing key cellular pathways.

Structure-Activity Relationship at the 8-Position

Modification at the 8-position of the adenosine scaffold has a significant impact on the conformational preference of the molecule, particularly the glycosidic bond, which in turn affects receptor binding and activation. The nature of the substituent at this position—its size, lipophilicity, and electronic properties—plays a pivotal role in determining the analog's affinity and selectivity profile across the adenosine receptor family.

Impact of 8-Position Substituents on Receptor Affinity and Selectivity

Systematic studies have explored a variety of substituents at the 8-position, including halo, amino, aryl, and cycloalkyl groups. Here, we summarize the key SAR findings:

- **Halogen Substituents:** The introduction of halogens at the 8-position has been shown to modulate receptor affinity. For instance, 8-chloroadenosine has been investigated for its unique biological activities, including its role as an RNA-directed nucleoside analog.
- **Amino Substituents:** 8-aminoadenosine and its derivatives have demonstrated interesting pharmacological properties. These analogs can influence cellular processes by affecting ATP levels and mRNA synthesis. From a receptor interaction perspective, the amino group can participate in hydrogen bonding within the receptor binding pocket, influencing affinity and efficacy.
- **Aryl and Heteroaryl Substituents:** The introduction of bulky aryl or heteroaryl groups at the 8-position can lead to significant changes in receptor selectivity. These substituents can engage in hydrophobic and aromatic interactions within the binding site, often favoring one receptor subtype over others. For example, certain 8-phenyl and 8-styryl derivatives have been explored, particularly in the context of xanthine antagonists, providing insights into the steric and electronic requirements of the binding pocket.
- **Alkynyl and Cycloalkyl Substituents:** Alkynyl chains at the C-8 position have been shown to produce selective antagonists for the A₃ adenosine receptor.^[1] Cycloalkyl groups, on the other hand, have been extensively studied in the context of 8-substituted xanthines, where they contribute to high affinity and selectivity for the A₁ receptor.

Quantitative Data on 8-Position Adenosine Analogs

The following tables summarize the binding affinities (K_i) and functional potencies (EC₅₀) of representative 8-position substituted adenosine analogs at the four human adenosine receptor subtypes. This data is compiled from various scientific publications and is intended to provide a comparative overview.

Table 1: Binding Affinities (K_i, nM) of 8-Substituted Adenosine Analogs

Compound	8-Substituent	A ₁ Receptor	A _{2A} Receptor	A _{2B} Receptor	A ₃ Receptor	Reference
1	-H (Adenosine)	1,200	15,000	>100,000	3,700	
2	-Cl					
3	-NH ₂					
4	-Phenyl					
5	- Cyclopentyl					
6	-Ethynyl	[1]				

Data to be populated from further targeted literature searches for specific quantitative values.

Table 2: Functional Potencies (EC₅₀, nM) of 8-Substituted Adenosine Analogs

Compound	8-Substituent	A ₁ Receptor (cAMP↓)	A _{2A} Receptor (cAMP↑)	A _{2B} Receptor (cAMP↑)	A ₃ Receptor (cAMP↓)	Reference
1	-H (Adenosine)	74	140	22,000	230	
2	-Cl					
3	-NH ₂					
4	-Phenyl					
5	- Cyclopentyl					
6	-Ethynyl	[1]				

Data to be populated from further targeted literature searches for specific quantitative values.

Experimental Protocols

Accurate and reproducible experimental data are the cornerstone of SAR studies. This section provides detailed methodologies for key experiments used to characterize 8-position adenosine analogs.

Radioligand Binding Assays

Radioligand binding assays are used to determine the affinity of a test compound for a specific receptor. These assays involve competing the binding of a radiolabeled ligand with the unlabeled test compound.

Protocol for A₁ Adenosine Receptor Radioligand Binding Assay:

- Membrane Preparation: Membranes are prepared from cells stably expressing the human A₁ adenosine receptor (e.g., CHO or HEK-293 cells).
- Assay Buffer: 50 mM Tris-HCl, pH 7.4.

- Radioligand: [³H]CCPA (2-chloro-N⁶-cyclopentyladenosine) at a final concentration of 1-2 nM.
- Non-specific Binding Determination: 10 μM R-PIA (N⁶-(R)-phenylisopropyladenosine) is used to determine non-specific binding.
- Incubation: Test compounds at various concentrations are incubated with the cell membranes and radioligand in the assay buffer for 60-90 minutes at room temperature.
- Filtration: The incubation is terminated by rapid filtration through glass fiber filters (e.g., Whatman GF/B).
- Washing: The filters are washed with ice-cold assay buffer to remove unbound radioligand.
- Quantification: The amount of radioactivity bound to the filters is determined by liquid scintillation counting.
- Data Analysis: The IC₅₀ values are determined by non-linear regression analysis of the competition binding curves. The K_i values are then calculated using the Cheng-Prusoff equation.

Functional Assays: cAMP Accumulation

Functional assays measure the biological response elicited by a compound upon binding to its target receptor. For adenosine receptors, which are G-protein coupled receptors (GPCRs), changes in intracellular cyclic adenosine monophosphate (cAMP) levels are a common readout.

Protocol for A_{2A} Adenosine Receptor cAMP Accumulation Assay:

- Cell Culture: HEK-293 cells stably expressing the human A_{2A} adenosine receptor are cultured to 80-90% confluency.
- Cell Plating: Cells are seeded into 96-well plates and incubated overnight.
- Assay Medium: The growth medium is replaced with a stimulation buffer (e.g., HBSS) containing a phosphodiesterase inhibitor such as IBMX (3-isobutyl-1-methylxanthine) to prevent cAMP degradation.

- **Compound Addition:** Test compounds at various concentrations are added to the wells.
- **Incubation:** The plate is incubated at 37°C for a specified time (e.g., 30 minutes).
- **Cell Lysis:** The cells are lysed to release intracellular cAMP.
- **cAMP Quantification:** The concentration of cAMP is determined using a commercially available cAMP assay kit (e.g., HTRF, LANCE, or ELISA-based kits).
- **Data Analysis:** The EC₅₀ values and maximal response (E_{max}) are determined by plotting the concentration-response curves and fitting the data to a sigmoidal dose-response model.

Signaling Pathways and Experimental Workflows

The following diagrams, generated using the DOT language, illustrate the key signaling pathways of adenosine receptors and a typical experimental workflow for SAR studies.

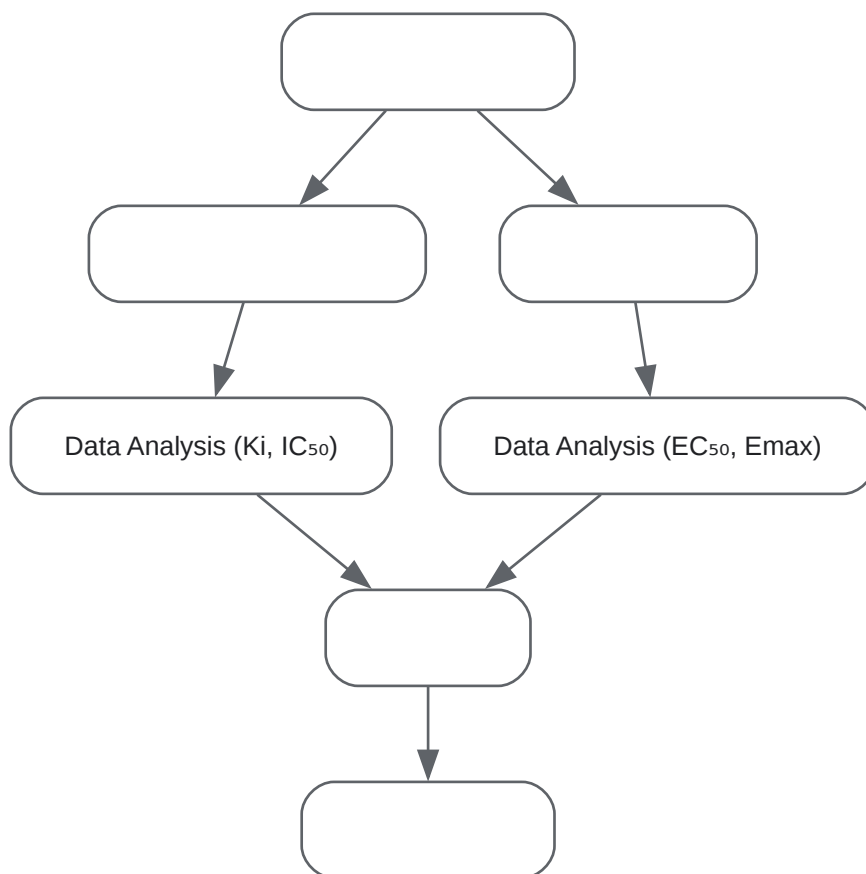
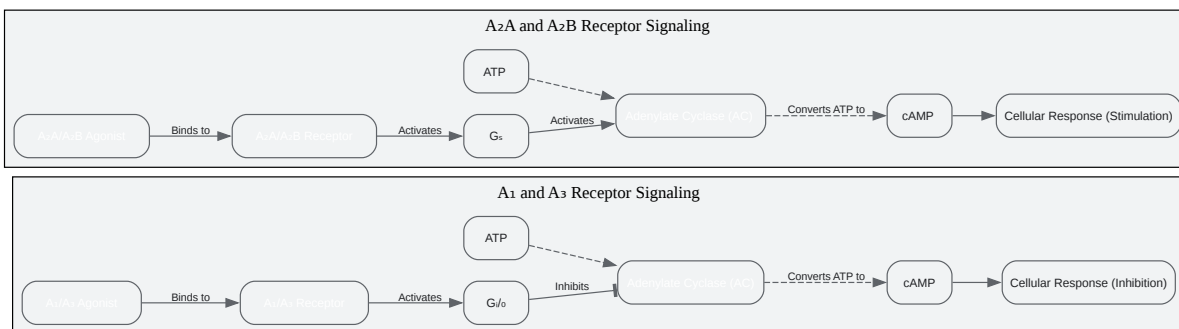

[Click to download full resolution via product page](#)

Need Custom Synthesis?

BenchChem offers custom synthesis for rare earth carbides and specific isotopic labeling.

Email: info@benchchem.com or [Request Quote Online](#).

References

- 1. Recent developments in adenosine receptor ligands and their potential as novel drugs - PMC [[pmc.ncbi.nlm.nih.gov](https://pubmed.ncbi.nlm.nih.gov/)]
- To cite this document: BenchChem. [The 8-Position: A Key Determinant in Adenosine Analog Structure-Activity Relationship]. BenchChem, [2026]. [Online PDF]. Available at: [<https://www.benchchem.com/product/b12390488/docs#the-8-position-a-key-determinant-in-adenosine-analog-structure-activity-relationship>]

Disclaimer & Data Validity:

The information provided in this document is for Research Use Only (RUO) and is strictly not intended for diagnostic or therapeutic procedures. While BenchChem strives to provide accurate protocols, we make no warranties, express or implied, regarding the fitness of this product for every specific experimental setup.

Technical Support: The protocols provided are for reference purposes. Unsure if this reagent suits your experiment?

Need Industrial/Bulk Grade? [Request Custom Synthesis Quote](#)

BenchChem

Our mission is to be the trusted global source of essential and advanced chemicals, empowering scientists and researchers to drive progress in science and industry.

Contact

Address: 3281 E Guasti Rd
Ontario, CA 91761, United States
Phone: (601) 213-4426
Email: info@benchchem.com

Contact our Ph.D. Support Team for a compatibility check