

Application Notes and Protocols: 2-Cyanoadenosine in Adenosine Receptor Binding Assays

Author: BenchChem Technical Support Team. **Date:** April 2026

Compound of Interest

Compound Name: 2-Cyanoadenosine

Cat. No.: B12390568

[Get Quote](#)

For Researchers, Scientists, and Drug Development Professionals

Introduction

Adenosine receptors, a class of G protein-coupled receptors (GPCRs), are integral to a multitude of physiological processes and represent significant targets for therapeutic intervention. These receptors are classified into four subtypes: A1, A2A, A2B, and A3. The development of selective ligands for these receptors is crucial for elucidating their roles in health and disease and for the discovery of novel therapeutics. **2-Cyanoadenosine** is a synthetic analog of adenosine that has been utilized in the study of adenosine receptors. Its utility in receptor binding assays stems from its ability to compete with radiolabeled ligands, allowing for the characterization of receptor-ligand interactions. These application notes provide a comprehensive overview of the use of **2-Cyanoadenosine** in adenosine receptor binding assays, including detailed protocols and data presentation.

Data Presentation: Binding Affinity of Adenosine Receptor Ligands

The affinity of a ligand for its receptor is a critical parameter in drug discovery and is typically expressed as the inhibition constant (K_i) or the half-maximal inhibitory concentration (IC₅₀). While comprehensive binding data for **2-Cyanoadenosine** across all adenosine receptor subtypes is not extensively documented in a single source, the following table summarizes the reported binding affinities for **2-Cyanoadenosine** and other relevant standard adenosine receptor ligands for comparative purposes. This data has been compiled from various scientific publications.

Compound	A1 K _i (nM)	A2A K _i (nM)	A2B K _i (nM)	A3 K _i (nM)
2-Cyanoadenosine	Data not readily available	Data not readily available	Data not readily available	Data not readily available
Adenosine	~300	~700	>10,000	~300
NECA	0.8	1.4	630	3.2
CGS-21680	2900	27	>100,000	1800
R-PIA	1.1	240	>100,000	440
IB-MECA	250	500	>100,000	1.0

Note: The absence of readily available, consolidated binding data for **2-Cyanoadenosine** highlights a gap in the current literature. Researchers are encouraged to determine these values empirically using the protocols outlined below.

Experimental Protocols

I. Membrane Preparation from Cells Expressing Adenosine Receptors

This protocol describes the preparation of cell membranes enriched with a specific adenosine receptor subtype.

Materials:

- Cells expressing the adenosine receptor of interest (e.g., HEK293, CHO)

- Phosphate-Buffered Saline (PBS), ice-cold
- Lysis Buffer: 50 mM Tris-HCl, pH 7.4, with protease inhibitors (e.g., cComplete™ Protease Inhibitor Cocktail)
- Homogenizer (Dounce or Potter-Elvehjem)
- High-speed centrifuge
- Bradford assay reagents for protein quantification

Procedure:

- Harvest cultured cells and wash twice with ice-cold PBS by centrifugation at 1,000 x g for 5 minutes at 4°C.
- Resuspend the cell pellet in ice-cold Lysis Buffer.
- Homogenize the cell suspension with 10-20 strokes in a Dounce homogenizer or by passing through a 25-gauge needle multiple times.
- Centrifuge the homogenate at 1,000 x g for 10 minutes at 4°C to remove nuclei and intact cells.
- Transfer the supernatant to a new tube and centrifuge at 40,000 x g for 30 minutes at 4°C to pellet the membranes.
- Discard the supernatant and resuspend the membrane pellet in an appropriate Assay Buffer.
- Determine the protein concentration of the membrane preparation using the Bradford assay.
- Store the membrane preparations in aliquots at -80°C until use.

II. Radioligand Competition Binding Assay

This protocol details the methodology for a competitive binding assay to determine the affinity of **2-Cyanoadenosine** for a specific adenosine receptor subtype.

Materials:

- Membrane preparation containing the adenosine receptor of interest
- Radioligand specific for the receptor subtype (e.g., [³H]DPCPX for A1, [³H]CGS-21680 for A2A, [¹²⁵I]AB-MECA for A3)
- **2-Cyanoadenosine**
- Assay Buffer: 50 mM Tris-HCl, pH 7.4, 5 mM MgCl₂, 1 mM EDTA
- Non-specific binding control (e.g., a high concentration of a non-radiolabeled standard ligand like NECA)
- 96-well microplates
- Scintillation vials and scintillation fluid
- Liquid scintillation counter
- Glass fiber filters (e.g., Whatman GF/B or GF/C)
- Filtration apparatus

Procedure:

- Prepare a dilution series of **2-Cyanoadenosine** in Assay Buffer.
- In a 96-well microplate, add in the following order:
 - 50 μL of Assay Buffer (for total binding) or non-specific binding control (for non-specific binding) or **2-Cyanoadenosine** dilution.
 - 50 μL of the radioligand at a concentration close to its K_d.
 - 100 μL of the membrane preparation (protein concentration optimized for the specific receptor).
- Incubate the plate at room temperature (or 37°C) for 60-120 minutes with gentle agitation to reach equilibrium.

- Terminate the binding reaction by rapid filtration through glass fiber filters pre-soaked in Assay Buffer.
- Wash the filters three times with 3 mL of ice-cold Assay Buffer to remove unbound radioligand.
- Place the filters in scintillation vials, add 4-5 mL of scintillation fluid, and vortex.
- Measure the radioactivity in a liquid scintillation counter.

Data Analysis:

- Calculate the specific binding by subtracting the non-specific binding from the total binding.
- Plot the percentage of specific binding against the logarithm of the **2-Cyanoadenosine** concentration.
- Determine the IC₅₀ value from the resulting sigmoidal curve using non-linear regression analysis (e.g., in GraphPad Prism).
- Calculate the K_i value using the Cheng-Prusoff equation: $K_i = IC_{50} / (1 + [L]/K_d)$, where [L] is the concentration of the radioligand and K_d is its dissociation constant.

Mandatory Visualizations

Adenosine Receptor Signaling Pathways

The four adenosine receptor subtypes couple to different G proteins and initiate distinct intracellular signaling cascades.

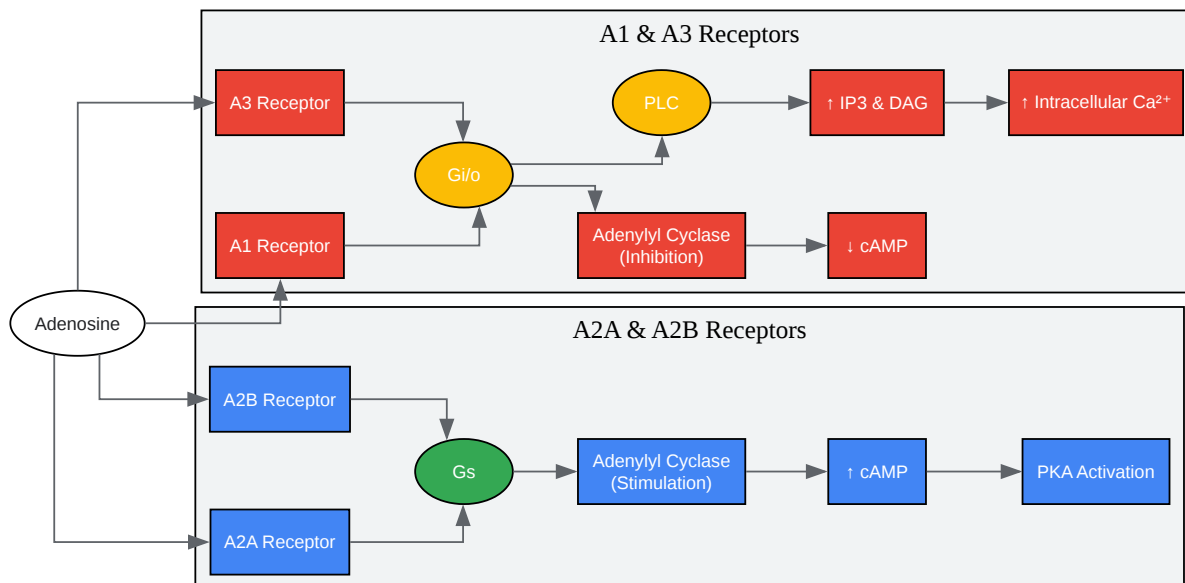

[Click to download full resolution via product page](#)

Caption: Overview of Adenosine Receptor Signaling Pathways.

Experimental Workflow for Competitive Binding Assay

The following diagram illustrates the key steps involved in performing a competitive radioligand binding assay.

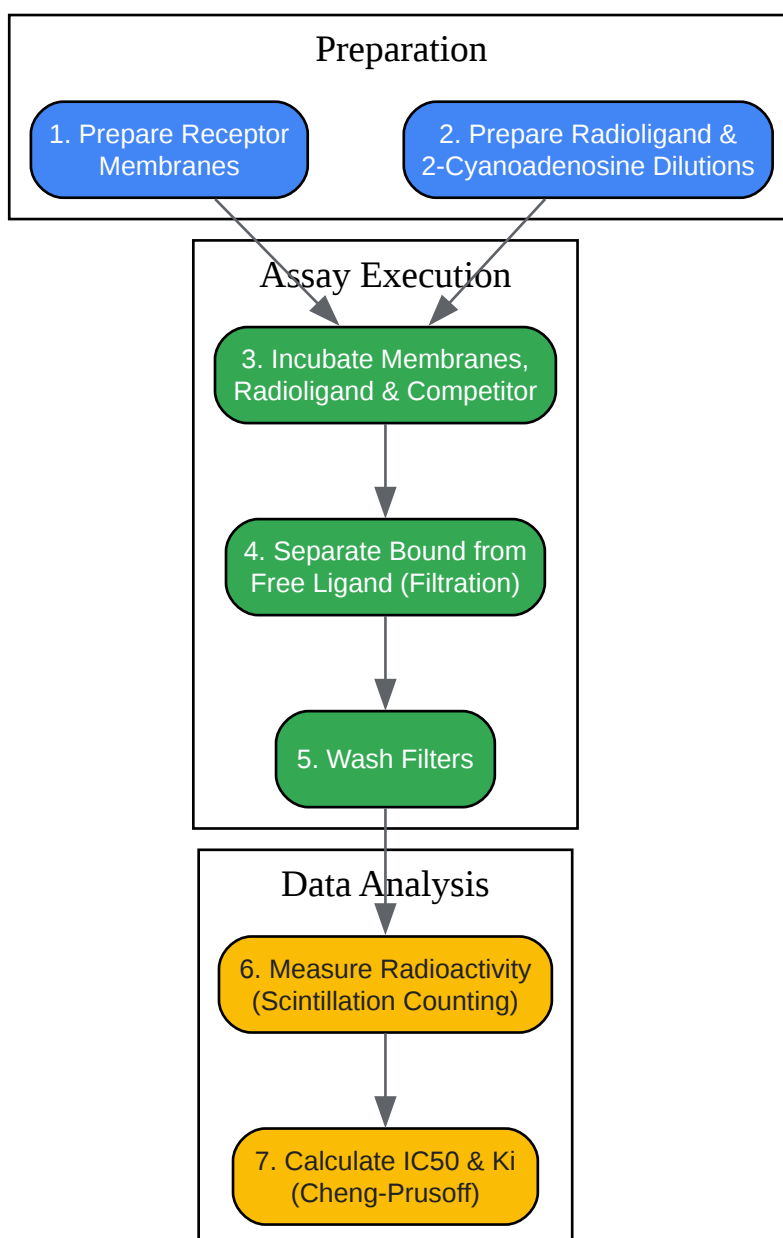

[Click to download full resolution via product page](#)

Caption: Workflow for a Competitive Radioligand Binding Assay.

- To cite this document: BenchChem. [Application Notes and Protocols: 2-Cyanoadenosine in Adenosine Receptor Binding Assays]. BenchChem, [2026]. [Online PDF]. Available at: [\[https://www.benchchem.com/product/b12390568/docs#application-notes-and-protocols-2-cyanoadenosine-in-adenosine-receptor-binding-assays\]](https://www.benchchem.com/product/b12390568/docs#application-notes-and-protocols-2-cyanoadenosine-in-adenosine-receptor-binding-assays)

Disclaimer & Data Validity:

The information provided in this document is for Research Use Only (RUO) and is strictly not intended for diagnostic or therapeutic procedures. While BenchChem strives to provide accurate protocols, we make no warranties, express or implied, regarding the fitness of this product for every specific experimental setup.

Technical Support: The protocols provided are for reference purposes. Unsure if this reagent suits your experiment?

Need Industrial/Bulk Grade? [Request Custom Synthesis Quote](#)

BenchChem

Our mission is to be the trusted global source of essential and advanced chemicals, empowering scientists and researchers to drive progress in science and industry.

Contact

Address: 3281 E Guasti Rd
Ontario, CA 91761, United States
Phone: (601) 213-4426
Email: info@benchchem.com

[Contact our Ph.D. Support Team for a compatibility check](#)