

Abcg2-IN-2: A Technical Guide to Target Specificity and Selectivity

Author: BenchChem Technical Support Team. **Date:** April 2026

Compound of Interest

Compound Name: Abcg2-IN-2

Cat. No.: B12390043

[Get Quote](#)

For Researchers, Scientists, and Drug Development Professionals

This technical guide provides a comprehensive overview of the target specificity and selectivity of **Abcg2-IN-2**, a potent inhibitor of the ATP-binding cassette subfamily G member 2 (ABCG2) transporter. ABCG2, also known as breast cancer resistance protein (BCRP), is a key player in multidrug resistance (MDR) in cancer and influences the pharmacokinetics of numerous drugs. This document summarizes the available quantitative data, details relevant experimental protocols, and visualizes key pathways and workflows to support further research and development of this compound.

Core Target Profile of Abcg2-IN-2

Abcg2-IN-2, also identified as K2 in the primary literature, is a novel analog of the well-characterized ABCG2 inhibitor Ko143. Developed through a metabolism-guided approach, **Abcg2-IN-2** was designed to overcome the metabolic instability of its parent compound. The key modification involves the replacement of the labile t-butyl ester moiety of Ko143 with an amide group, leading to improved metabolic stability and favorable oral pharmacokinetic profiles in mice[1][2].

Quantitative Assessment of Inhibitory Potency and Selectivity

The inhibitory activity of **Abcg2-IN-2** has been primarily characterized against its intended target, ABCG2. While specific IC₅₀ values for **Abcg2-IN-2** against other major ABC transporters like P-glycoprotein (P-gp/ABCB1) and Multidrug Resistance-Associated Protein 1 (MRP1/ABCC1) are not detailed in the currently accessible literature, the development from Ko143, a known selective ABCG2 inhibitor, suggests a favorable selectivity profile. Further head-to-head comparative studies are necessary for a complete quantitative comparison.

Compound	Target	Assay Type	IC ₅₀ / EC ₅₀	Reference
Abcg2-IN-2 (K2)	ABCG2	Protoporphyrin IX (PPIX)-based cellular assay	Data not yet publicly available in abstracts.	Based on[1][2]
Ko143 (Parent Compound)	ABCG2	Not Specified	Potent Inhibitor	[1][2]

Note: The primary publication detailing the specific quantitative data for **Abcg2-IN-2** (Zhu et al., 2023) was not fully accessible at the time of this compilation. The information presented is based on the available abstract and supplementary data.

Experimental Protocols

The characterization of **Abcg2-IN-2**'s target specificity and selectivity involves a series of in vitro and in vivo assays. Below are detailed methodologies for key experiments typically employed in the evaluation of ABCG2 inhibitors.

In Vitro ABCG2 Inhibition Assay (Protoporphyrin IX Accumulation)

This cellular assay is used to determine the inhibitory activity of compounds against ABCG2 by measuring the accumulation of the fluorescent substrate protoporphyrin IX (PPIX).

Principle: ABCG2 is an efflux transporter for PPIX. In the presence of an ABCG2 inhibitor, the efflux of PPIX is blocked, leading to its intracellular accumulation, which can be quantified by

fluorescence.

Methodology:

- Cell Culture: Utilize a cell line overexpressing ABCG2 (e.g., HEK293/ABCG2) and a corresponding parental cell line as a negative control.
- Compound Preparation: Prepare a dilution series of **Abcg2-IN-2** and a positive control inhibitor (e.g., Ko143).
- Induction of PPIX Production: Treat the cells with 5-aminolevulinic acid (ALA), a precursor that leads to the intracellular production of PPIX[2].
- Inhibitor Treatment: Co-incubate the ALA-treated cells with the various concentrations of **Abcg2-IN-2** or control compounds.
- Fluorescence Measurement: After a defined incubation period, measure the intracellular PPIX fluorescence using a plate reader or flow cytometer.
- Data Analysis: Calculate the half-maximal inhibitory concentration (IC50) by plotting the fluorescence intensity against the inhibitor concentration.

Selectivity Assays against other ABC Transporters (General Protocol)

To assess the selectivity of **Abcg2-IN-2**, its inhibitory activity should be tested against other clinically relevant ABC transporters, such as ABCB1 (P-gp) and ABCC1 (MRP1).

Principle: Similar to the ABCG2 inhibition assay, these assays utilize specific fluorescent substrates for each transporter. Inhibition of the transporter leads to increased intracellular accumulation of the substrate.

Methodology:

- Cell Lines: Use cell lines specifically overexpressing the transporter of interest (e.g., MDCKII-ABCB1, MDCKII-ABCC1).

- Substrates and Inhibitors:
 - For ABCB1 (P-gp): Use a fluorescent substrate like Rhodamine 123. A known P-gp inhibitor (e.g., Verapamil) can be used as a positive control.
 - For ABCC1 (MRP1): Use a fluorescent substrate like Calcein-AM. A known MRP1 inhibitor (e.g., MK-571) can be used as a positive control.
- Assay Procedure: The general procedure is similar to the ABCG2 inhibition assay, involving incubation of the cells with the substrate and a range of **Abcg2-IN-2** concentrations, followed by fluorescence measurement.
- Data Analysis: Determine the IC₅₀ values for each transporter to quantify the selectivity profile of **Abcg2-IN-2**.

Visualizing the Mechanism and Experimental Workflow

ABCG2-Mediated Drug Efflux and Inhibition

The following diagram illustrates the fundamental mechanism of ABCG2-mediated drug efflux and the point of intervention for an inhibitor like **Abcg2-IN-2**.

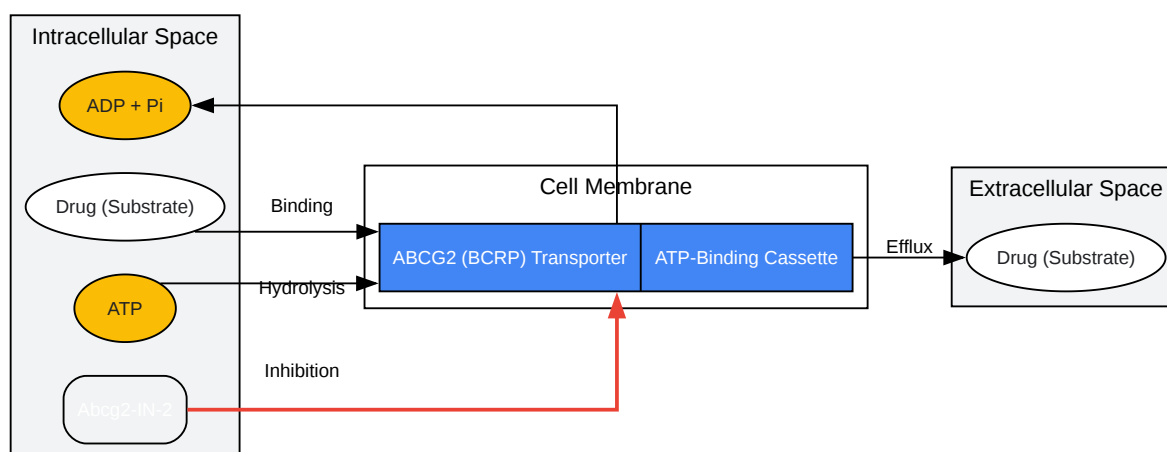

[Click to download full resolution via product page](#)

Caption: ABCG2-mediated drug efflux pathway and its inhibition.

Experimental Workflow for Characterizing Abcg2-IN-2

The following diagram outlines the typical experimental workflow for the comprehensive characterization of a novel ABCG2 inhibitor.

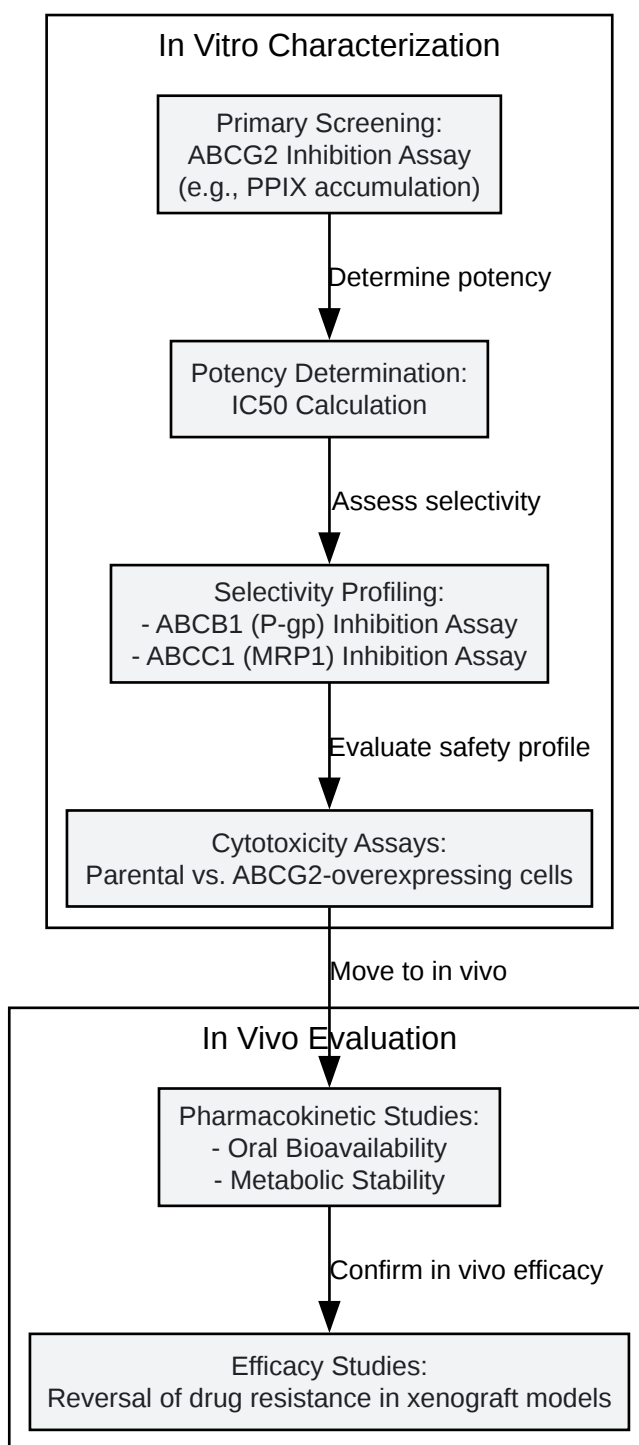

[Click to download full resolution via product page](#)

Need Custom Synthesis?

BenchChem offers custom synthesis for rare earth carbides and specific isotopic labeling.

Email: info@benchchem.com or [Request Quote Online](#).

References

- 1. Metabolism-guided development of Ko143 analogs as ABCG2 inhibitors - PubMed [pubmed.ncbi.nlm.nih.gov]
- 2. Metabolism-guided development of Ko143 analogs as ABCG2 inhibitors - PMC [pmc.ncbi.nlm.nih.gov]
- To cite this document: BenchChem. [Abcg2-IN-2: A Technical Guide to Target Specificity and Selectivity]. BenchChem, [2026]. [Online PDF]. Available at: [<https://www.benchchem.com/product/b12390043/docs#abcg2-in-2-a-technical-guide-to-target-specificity-and-selectivity>]

Disclaimer & Data Validity:

The information provided in this document is for Research Use Only (RUO) and is strictly not intended for diagnostic or therapeutic procedures. While BenchChem strives to provide accurate protocols, we make no warranties, express or implied, regarding the fitness of this product for every specific experimental setup.

Technical Support: The protocols provided are for reference purposes. Unsure if this reagent suits your experiment?

Need Industrial/Bulk Grade? [Request Custom Synthesis Quote](#)

BenchChem

Our mission is to be the trusted global source of essential and advanced chemicals, empowering scientists and researchers to drive progress in science and industry.

Contact

Address: 3281 E Guasti Rd

Ontario, CA 91761, United States

Phone: (601) 213-4426

Email: info@benchchem.com

Contact our Ph.D. Support Team for a compatibility check