

# Application Notes and Protocols for Neomycin in Molecular Biology

**Author:** BenchChem Technical Support Team. **Date:** May 2026

## Compound of Interest

Compound Name: *Neocopiamycin A*

CAS No.: 89989-28-6

Cat. No.: B1239056

[Get Quote](#)

A Senior Application Scientist's Guide for Researchers and Drug Development Professionals

Editor's Note: The initial topic specified "**Neocopiamycin A.**" However, extensive database searches yielded no matching compound. Based on the phonetic similarity, this guide has been developed for Neomycin, a widely studied aminoglycoside antibiotic with significant applications in molecular biology. We believe this will best serve the user's intended query.

## Introduction: Beyond an Antibiotic - Neomycin as a Molecular Probe

Neomycin, a complex of related aminoglycoside antibiotics produced by *Streptomyces fradiae*, is most recognized for its potent bactericidal activity.[1][2] Commercially available neomycin is primarily a mixture of Neomycin B and Neomycin C, with Neomycin B being the most active component.[3] While its clinical use is often topical due to potential nephrotoxicity and ototoxicity, its unique molecular interactions have made it an invaluable tool in the molecular biology laboratory.[4][5] This guide provides an in-depth exploration of Neomycin's mechanisms of action and offers detailed protocols for its application in contemporary research and drug development.

## Unraveling the Multifaceted Mechanism of Action

Neomycin's utility in molecular biology stems from its ability to interact with various biomolecules, leading to distinct downstream effects in both prokaryotic and eukaryotic systems.

### Primary Antibacterial Action: Inhibition of Protein Synthesis

The canonical mechanism of neomycin's antibacterial effect is the disruption of protein synthesis.[4][6] It specifically binds to the 30S ribosomal subunit in bacteria, inducing a misreading of the mRNA codon.[3][7][8] This leads to the incorporation of incorrect amino acids into the growing polypeptide chain, resulting in non-functional or toxic proteins and ultimately, bacterial cell death.[7][8]

Diagram: Mechanism of Neomycin's Antibacterial Action

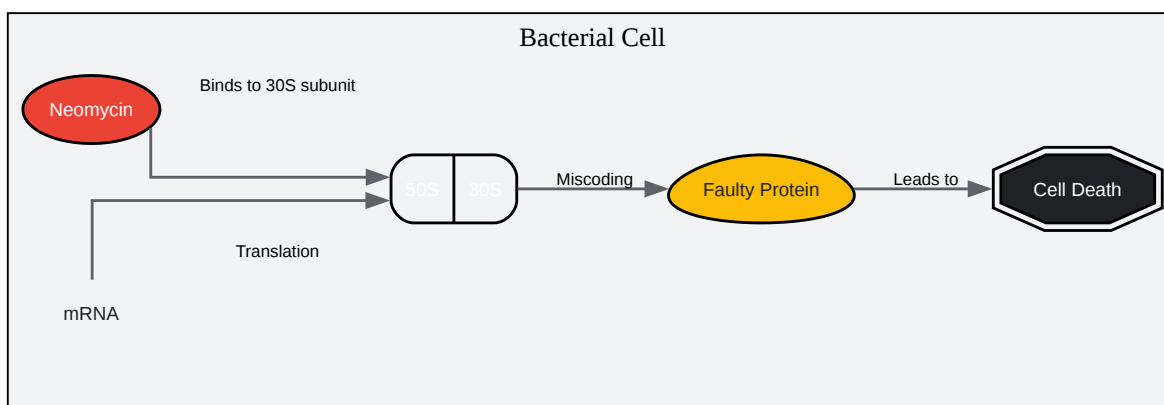

[Click to download full resolution via product page](#)

Caption: Neomycin binds to the 30S ribosomal subunit, causing mRNA misreading and the synthesis of faulty proteins, leading to bacterial cell death.

## Eukaryotic Cell Interactions: A Tool for Signal Transduction and Gene Regulation

In eukaryotic cells, neomycin exhibits several interesting activities that can be harnessed for research purposes:

- **Interaction with G-Protein Coupled Receptors (GPCRs):** Neomycin can influence the binding of agonists to their GPCRs. Studies have shown that neomycin can induce high-affinity agonist binding to formyl peptide receptors and beta-adrenoceptors, mimicking the effect of magnesium ions.[\[9\]](#) This property can be utilized in studies of GPCR signaling and ligand binding assays.
- **Inhibition of Phospholipase C (PLC):** Neomycin is known to bind to inositol phospholipids, thereby interfering with signal transduction pathways that involve PLC.[\[9\]](#)
- **DNA and RNA Binding:** Neomycin has been shown to bind to A-form DNA structures and DNA:RNA hybrids, inducing thermal stabilization of triplex DNA.[\[10\]](#) This suggests potential applications in studies of nucleic acid structure and function. MP Biomedicals also highlights that Neomycin blocks RNA with high affinity.[\[11\]](#)
- **Effects on Gene Expression:** The presence of the neomycin resistance gene (neo) in mammalian cells has been observed to cause alterations in the expression of other endogenous genes. For instance, in NIH-3T3 cells, neo expression led to a decrease in procollagen 1 alpha and fibronectin mRNA levels, while increasing c-myc mRNA.[\[12\]](#) This is a critical consideration when using neomycin for selection, as it may introduce unintended variables.

## Core Application: Selectable Marker for Gene Transfer

The most widespread use of neomycin in molecular biology is for the selection of successfully transfected or transduced mammalian cells. This is made possible by the neomycin resistance gene (neo), which encodes an aminoglycoside phosphotransferase. This enzyme inactivates neomycin (and the related antibiotic G418 or Geneticin) by phosphorylation, allowing cells expressing the neo gene to survive in the presence of the antibiotic.[\[2\]](#)

## Protocol: Establishing Stable Mammalian Cell Lines Using Neomycin (G418) Selection

This protocol provides a general framework for generating stable cell lines. The optimal concentration of the selection agent must be determined empirically for each cell line.

### A. Determining the Optimal G418 Concentration (Kill Curve):

- **Cell Plating:** Plate your parental (non-transfected) cell line in a 24-well plate at a density that allows for several days of growth without reaching confluency.
- **G418 Titration:** The following day, replace the medium with fresh medium containing a range of G418 concentrations (e.g., 100, 200, 400, 600, 800, 1000 µg/mL). Include a "no G418" control.
- **Incubation and Observation:** Incubate the cells and observe them daily. Replace the G418-containing medium every 2-3 days.
- **Endpoint Analysis:** Monitor cell viability over 7-10 days. The optimal G418 concentration is the lowest concentration that results in complete cell death of the parental cells within this timeframe.

### B. Selection of Transfected Cells:

- **Transfection:** Transfect your cells with a plasmid vector containing your gene of interest and the neo resistance gene.
- **Recovery:** Allow the cells to recover and express the resistance gene for 24-48 hours post-transfection in non-selective medium.
- **Initiate Selection:** Replace the medium with complete growth medium supplemented with the predetermined optimal concentration of G418.
- **Maintenance and Observation:** Continue to culture the cells in the selective medium, replacing it every 2-3 days. Non-transfected cells will begin to die.
- **Colony Formation:** After 1-2 weeks, resistant colonies should become visible.

- Clonal Isolation: Isolate individual colonies using cloning cylinders or by limiting dilution and expand them to establish stable, clonal cell lines.

Diagram: Workflow for Generating Stable Cell Lines with Neomycin Selection

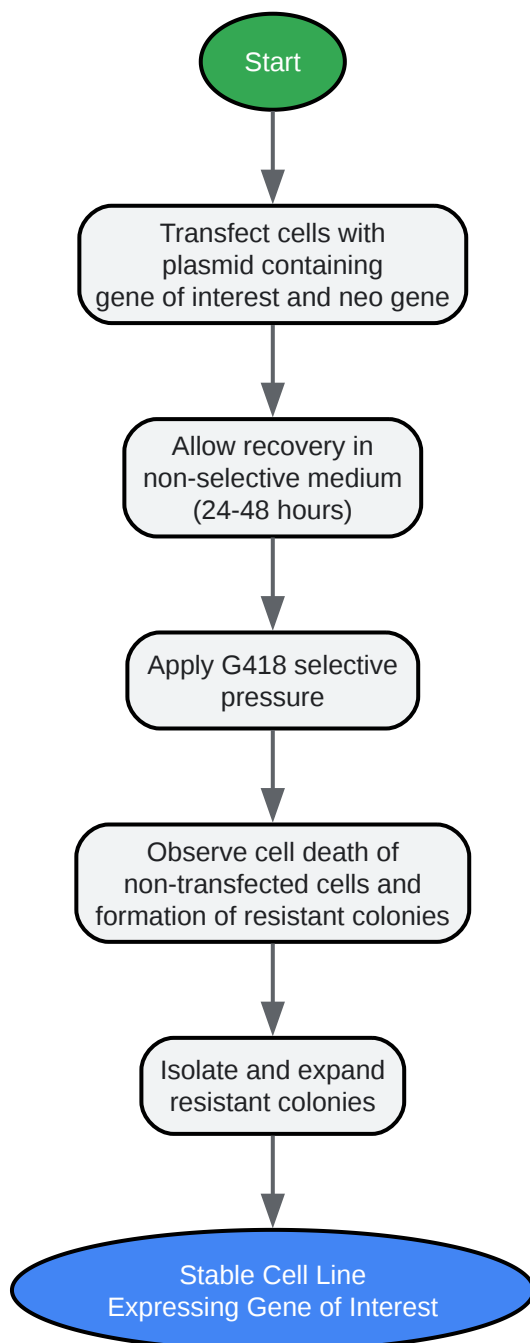

[Click to download full resolution via product page](#)

Caption: A streamlined workflow for the generation of stable mammalian cell lines using neomycin (G418) selection.

## Neomycin in Cancer Research: Exploring Anti-Proliferative and Anti-Angiogenic Effects

Emerging research has highlighted the potential of neomycin as an anti-cancer agent.<sup>[5]</sup> Its mechanisms in this context are distinct from its antibiotic activity and offer avenues for therapeutic development.

### Inhibition of Glioma Cell Proliferation

Neomycin has been shown to inhibit the proliferation of glioma cells in vitro.<sup>[5]</sup> This effect is mediated through the downregulation of cyclin D1, a key regulator of the G1-to-S phase transition in the cell cycle.<sup>[5]</sup> Additionally, neomycin can inhibit the p42/44 mitogen-activated protein kinase (MAPK) and cAMP response element-binding protein (CREB) pathways, both of which are crucial for growth factor-mediated signal transduction and cell survival in glioma cells.<sup>[5]</sup>

### Anti-Angiogenic Properties

Neomycin exhibits anti-angiogenic effects by inhibiting the nuclear translocation of angiogenin, a potent inducer of neovascularization.<sup>[5]</sup> This has been observed in human umbilical vein endothelial (HUVE) cells.<sup>[5]</sup>

## Protocol: Assessing the Anti-Proliferative Effects of Neomycin using an MTT Assay

This protocol allows for the quantitative assessment of neomycin's cytotoxic or cytostatic effects on cancer cell lines.

- **Cell Seeding:** Seed cancer cells (e.g., glioma cell lines) in a 96-well plate at a predetermined optimal density and allow them to adhere overnight.
- **Neomycin Treatment:** The next day, treat the cells with a serial dilution of neomycin sulfate. A study on various mammalian cell lines used concentrations ranging from 1000 to 20000 µg/mL.<sup>[13]</sup> Include a vehicle-treated control group.

- Incubation: Incubate the cells for a defined period (e.g., 24, 48, or 72 hours).
- MTT Addition: Add MTT (3-(4,5-dimethylthiazol-2-yl)-2,5-diphenyltetrazolium bromide) solution to each well and incubate for 2-4 hours at 37°C.
- Formazan Solubilization: Remove the MTT solution and add a solubilizing agent (e.g., DMSO or a specialized solubilization buffer) to dissolve the formazan crystals.
- Absorbance Measurement: Measure the absorbance at a wavelength of 570 nm using a microplate reader.
- Data Analysis: Calculate cell viability as a percentage of the vehicle-treated control and plot a dose-response curve to determine the IC50 value (the concentration of neomycin that inhibits cell growth by 50%).

Table 1: Representative Cytotoxicity Data of Neomycin on Mammalian Cell Lines

Cell Line	Concentration Range (µg/mL)	Significant Decrease in Viability Observed at (µg/mL)	Reference
BHK-21	1000 - 20000	9000, 10000, 20000	[13]
FEA	1000 - 20000	3000	[13]

Note: This table is illustrative. Researchers should perform their own dose-response experiments for their specific cell lines of interest.

## Considerations and Best Practices

- Purity and Formulation: Use a high-purity, sterile-filtered neomycin sulfate solution for cell culture applications.
- Solubility: Neomycin sulfate is sparingly soluble in organic solvents but readily soluble in aqueous buffers.[14] It is recommended to prepare fresh aqueous solutions for biological experiments.[14]

- Storage: For long-term storage, neomycin sulfate should be stored at -20°C as a solid, where it is stable for at least two years.[14] Aqueous solutions should not be stored for more than one day.[14]
- Off-Target Effects: Be mindful of the potential for neomycin and the neo gene to influence endogenous gene expression and cellular metabolism.[12][15] Appropriate controls, such as cells transfected with a vector lacking the gene of interest but containing the neo gene, are essential for rigorous interpretation of experimental results.

## References

- Patsnap Synapse. (2024, July 17). What is the mechanism of Neomycin Sulfate?
- Pharmacology of Neomycin (Sulfate) ; Pharmacokinetics, Mechanism of action, Uses, Effects. (2024, December 18).
- Neomycin - PubMed. (2023, November 12).
- Neomycin Protocol and Selection Guide - ResearchGate.
- Bera, S., et al. (2012). Synthesis and Antibacterial Activities of Amphiphilic Neomycin B-based Bilipid Conjugates and Fluorinated Neomycin B-based Lipids. PubMed Central.
- Murine bone marrow expressing the neomycin resistance gene has no competitive disadvantage assessed in vivo - PubMed.
- Binding of Neomycin-Class Aminoglycoside Antibiotics to Mutant Ribosomes with Alterations in the A Site of 16S rRNA - PMC - NIH.
- Neomycin - StatPearls - NCBI Bookshelf - NIH. (2023, November 12).
- Neomycin | C23H46N6O13 | CID 8378 - PubChem - NIH.
- Neomycin - Wikipedia.
- Neomycin induces high-affinity agonist binding of G-protein-coupled receptors - PubMed. (1989, November 20).
- Antitumor effect of a new antibiotic, neothramycin - PubMed.
- Expression of the neomycin-resistance (neo) gene induces alterations in gene expression and metabolism - PubMed. (1994, April).
- Cytotoxic effect of aminoglycoside antibiotics on the mammalian cell lines - PubMed. (2020, October 10).
- Synthesis and antibacterial activities of amphiphilic neomycin B-based bilipid conjugates and fluorinated neomycin B-based lipids - PubMed. (2012, August 2).
- Neomycin Applications - AG Scientific.
- Neomycin and puromycin affect gene expression in Giardia lamblia stable transfection.
- Protocol for Subculturing NIH3T3-47 Cell Line - NEB.
- Antimicrobial Activity of Four Antibiotics... - ResearchGate.

- [Unraveling the Anti-Cancer Mechanisms of Antibiotics... - MDPI.](#)
- [Neomycin Sulfate - FAQs - Thermo Fisher Scientific.](#)
- [neomycin | Ligand page | IUPHAR/BPS Guide to PHARMACOLOGY.](#)
- [Eliminating senescent cancer cells with antibiotics. \(2024, December 23\).](#)
- [10 mg/mL neomycin 1405-10-3 cell culture Sigma.](#)
- [Oncology Drugs Fast-Tracked by the FDA in January 2026. \(2026, January 5\).](#)
- [The prokaryotic neomycin-resistance-encoding gene acts as a transcriptional silencer in eukaryotic cells - PubMed.](#)
- [Antibiotics for Cell Culture | MP Biomedicals.](#)
- [Graduated resistance to G418 leads to differential selection of cultured mammalian cells expressing the neo gene - PubMed.](#)
- [Moenomycin family antibiotics: chemical synthesis, biosynthesis, biological activity - PMC - PubMed Central.](#)

### Need Custom Synthesis?

BenchChem offers custom synthesis for rare earth carbides and specific isotopic labeling.

Email: [info@benchchem.com](mailto:info@benchchem.com) or [Request Quote Online.](#)

## Sources

- [1. Neomycin | C23H46N6O13 | CID 8378 - PubChem \[pubchem.ncbi.nlm.nih.gov\]](#)
- [2. agscientific.com \[agscientific.com\]](#)
- [3. neomycin | Ligand page | IUPHAR/BPS Guide to PHARMACOLOGY \[guidetopharmacology.org\]](#)
- [4. What is the mechanism of Neomycin Sulfate? \[synapse.patsnap.com\]](#)
- [5. mdpi.com \[mdpi.com\]](#)
- [6. Neomycin - StatPearls - NCBI Bookshelf \[ncbi.nlm.nih.gov\]](#)
- [7. youtube.com \[youtube.com\]](#)
- [8. Neomycin - PubMed \[pubmed.ncbi.nlm.nih.gov\]](#)
- [9. Neomycin induces high-affinity agonist binding of G-protein-coupled receptors - PubMed \[pubmed.ncbi.nlm.nih.gov\]](#)
- [10. Neomycin - Wikipedia \[en.wikipedia.org\]](#)

- [11. mpbio.com \[mpbio.com\]](#)
- [12. Expression of the neomycin-resistance \(neo\) gene induces alterations in gene expression and metabolism - PubMed \[pubmed.ncbi.nlm.nih.gov\]](#)
- [13. Cytotoxic effect of aminoglycoside antibiotics on the mammalian cell lines - PubMed \[pubmed.ncbi.nlm.nih.gov\]](#)
- [14. researchgate.net \[researchgate.net\]](#)
- [15. Neomycin and puromycin affect gene expression in Giardia lamblia stable transfection - PubMed \[pubmed.ncbi.nlm.nih.gov\]](#)
- To cite this document: BenchChem. [Application Notes and Protocols for Neomycin in Molecular Biology]. BenchChem, [2026]. [Online PDF]. Available at: [\[https://www.benchchem.com/product/b1239056/docs#application-notes-and-protocols-for-neomycin-in-molecular-biology\]](https://www.benchchem.com/product/b1239056/docs#application-notes-and-protocols-for-neomycin-in-molecular-biology)

---

**Disclaimer & Data Validity:**

The information provided in this document is for Research Use Only (RUO) and is strictly not intended for diagnostic or therapeutic procedures. While BenchChem strives to provide accurate protocols, we make no warranties, express or implied, regarding the fitness of this product for every specific experimental setup.

**Technical Support:** The protocols provided are for reference purposes. Unsure if this reagent suits your experiment?

**Need Industrial/Bulk Grade?** [Request Custom Synthesis Quote](#)

## BenchChem

Our mission is to be the trusted global source of essential and advanced chemicals, empowering scientists and researchers to drive progress in science and industry.

### Contact

Address: 3281 E Guasti Rd  
Ontario, CA 91761, United States  
Phone: (601) 213-4426  
Email: [info@benchchem.com](mailto:info@benchchem.com)

Contact our Ph.D. Support Team for a compatibility check