

# Application Notes and Protocols: Utilizing Trifluoperazine Dimaleate in Cancer Cell Line Studies

**Author:** BenchChem Technical Support Team. **Date:** April 2026

## Compound of Interest

Compound Name: *Trifluoperazine dimaleate*

CAS No.: 605-75-4

Cat. No.: B1239252

[Get Quote](#)

For Researchers, Scientists, and Drug Development Professionals

## Introduction

Trifluoperazine (TFP), a phenothiazine derivative traditionally used as an antipsychotic agent, has garnered significant attention for its potential as a repurposed anticancer drug.[1]

Extensive in vitro studies have demonstrated its ability to inhibit proliferation, induce cell cycle arrest, and trigger apoptosis in a variety of cancer cell lines.[2][3][4] These application notes provide a comprehensive overview of the methodologies used to investigate the anticancer effects of **Trifluoperazine dimaleate** in a laboratory setting, complete with detailed experimental protocols and a summary of its impact on key cellular processes.

## Mechanisms of Action

Trifluoperazine exerts its anticancer effects through a multi-faceted approach, influencing several critical cellular pathways. It is known to be a calmodulin (CaM) antagonist, and its

interaction with this key calcium-binding protein is thought to be a primary mechanism of its action.[5][6] The downstream effects of TFP in cancer cells include:

- **Induction of Apoptosis:** TFP has been shown to induce programmed cell death in various cancer cell lines, including those from lung, colorectal, and triple-negative breast cancers.[3][4][7] This is often mediated through the intrinsic mitochondrial pathway, characterized by a decrease in mitochondrial membrane potential and an increase in reactive oxygen species (ROS).[3][8]
- **Cell Cycle Arrest:** A common finding in TFP-treated cancer cells is an arrest in the G0/G1 phase of the cell cycle.[3][4][9] This is typically accompanied by the downregulation of key cell cycle regulatory proteins such as cyclin-dependent kinases (CDK2, CDK4) and cyclins (Cyclin D1, Cyclin E), and the upregulation of cell cycle inhibitors like p27.[3]
- **Induction of Ferroptosis:** Recent studies have revealed that TFP can also induce ferroptosis, an iron-dependent form of programmed cell death, in oral cancer cells. This is achieved by targeting the SLC7A11/GPX4 axis, leading to an increase in lipid-derived ROS.[9]
- **Inhibition of Autophagy:** In some cancer models like multiple myeloma, TFP has been observed to inhibit autophagy, which can contribute to the induction of apoptosis.[1]
- **Modulation of Signaling Pathways:** TFP has been shown to impact several signaling pathways crucial for cancer cell survival and proliferation, including the PI3K/Akt and JNK/MAPK pathways.[10][11]

## Quantitative Data Summary

The following tables summarize the quantitative effects of **Trifluoperazine dimaleate** across various cancer cell lines as reported in the literature.

Table 1: IC50 Values of Trifluoperazine in Cancer Cell Lines

Cell Line	Cancer Type	IC50 Value (μM)	Treatment Duration (h)	Reference
HSC-3	Oral Squamous Cell Carcinoma	26.65 ± 1.1	24	[9]
Ca9-22	Oral Squamous Cell Carcinoma	23.49 ± 1.26	24	[9]
A549	Non-Small Cell Lung Cancer	Various concentrations tested	48	[5]
MiaPaCa-2	Pancreatic Ductal Adenocarcinoma	Dose-dependent cell death observed	24	[2]
PDX-derived cell lines	Pancreatic Ductal Adenocarcinoma	7.59 - 15.75	24	[2]

Table 2: Effect of Trifluoperazine on Cell Cycle Distribution

Cell Line	Cancer Type	TFP Concentration ( $\mu\text{M}$ )	% of Cells in G0/G1 Phase (Treated vs. Control)	Treatment Duration (h)	Reference
HSC-3	Oral Squamous Cell Carcinoma	Not specified	Significant increase	Not specified	[9]
Ca9-22	Oral Squamous Cell Carcinoma	Not specified	Significant increase	Not specified	[9]
HCT116	Colorectal Cancer	Not specified	Significant accumulation	12, 24, 48	[3]
CT26	Colorectal Cancer	Not specified	Significant accumulation	12, 24, 48	[3]
MDA-MB-468	Triple-Negative Breast Cancer	Not specified	Induced G0/G1 arrest	Not specified	[4]
MDA-MB-231	Triple-Negative Breast Cancer	Not specified	Induced G0/G1 arrest	Not specified	[4]
4T1	Triple-Negative Breast Cancer	Not specified	Induced G0/G1 arrest	Not specified	[4]

## Experimental Protocols

### Cell Viability Assay (MTT Assay)

This protocol is a standard method to assess the cytotoxic effects of **Trifluoperazine dimaleate** on cancer cell lines.

Materials:

- Cancer cell lines of interest
- Complete culture medium (e.g., DMEM, RPMI-1640) supplemented with 10% FBS and 1% penicillin-streptomycin
- **Trifluoperazine dimaleate** (TFP) stock solution
- 96-well plates
- MTT (3-(4,5-dimethylthiazol-2-yl)-2,5-diphenyltetrazolium bromide) solution (5 mg/mL in PBS)
- DMSO (Dimethyl sulfoxide)
- Microplate reader

Procedure:

- Seed cells in a 96-well plate at a density of  $5 \times 10^3$  to  $1 \times 10^4$  cells per well in 100  $\mu$ L of complete culture medium.
- Incubate the plate at 37°C in a humidified atmosphere with 5% CO<sub>2</sub> for 24 hours to allow for cell attachment.
- Prepare serial dilutions of TFP in complete culture medium at the desired concentrations.
- Remove the medium from the wells and add 100  $\mu$ L of the TFP-containing medium or vehicle control (medium with the same concentration of solvent used for TFP, e.g., DMSO) to each well.
- Incubate the cells for the desired treatment durations (e.g., 24, 48, 72 hours).

- After the incubation period, add 10  $\mu$ L of MTT solution to each well and incubate for an additional 2-4 hours at 37°C, allowing for the formation of formazan crystals.
- Carefully remove the medium and add 100  $\mu$ L of DMSO to each well to dissolve the formazan crystals.
- Gently shake the plate for 10 minutes to ensure complete dissolution.
- Measure the absorbance at 450-570 nm using a microplate reader.
- Calculate cell viability as a percentage of the vehicle-treated control.

## Apoptosis Assay (Annexin V-FITC/PI Staining)

This flow cytometry-based assay distinguishes between viable, early apoptotic, late apoptotic, and necrotic cells.

Materials:

- Cancer cell lines
- 6-well plates
- **Trifluoperazine dimaleate (TFP)**
- Annexin V-FITC Apoptosis Detection Kit (containing Annexin V-FITC, Propidium Iodide (PI), and Binding Buffer)
- Phosphate-buffered saline (PBS)
- Flow cytometer

Procedure:

- Seed cells in 6-well plates and allow them to attach overnight.
- Treat the cells with various concentrations of TFP or a vehicle control for the desired time period.

- After treatment, harvest the cells by trypsinization and collect both the adherent and floating cells.
- Wash the cells twice with cold PBS.
- Resuspend the cells in 1X Binding Buffer at a concentration of  $1 \times 10^6$  cells/mL.
- Transfer 100  $\mu$ L of the cell suspension ( $1 \times 10^5$  cells) to a flow cytometry tube.
- Add 5  $\mu$ L of Annexin V-FITC and 5  $\mu$ L of PI to the cell suspension.
- Gently vortex the cells and incubate for 15 minutes at room temperature in the dark.
- Add 400  $\mu$ L of 1X Binding Buffer to each tube.
- Analyze the samples by flow cytometry within one hour of staining.

## Cell Cycle Analysis (Propidium Iodide Staining)

This protocol uses propidium iodide (PI) to stain cellular DNA, allowing for the analysis of cell cycle distribution by flow cytometry.

Materials:

- Cancer cell lines
- 6-well plates
- **Trifluoperazine dimaleate (TFP)**
- PBS
- 70% Ethanol (ice-cold)
- RNase A solution
- Propidium Iodide (PI) staining solution
- Flow cytometer

**Procedure:**

- Seed cells in 6-well plates and treat with TFP as described for the apoptosis assay.
- Harvest the cells by trypsinization.
- Wash the cells with cold PBS and centrifuge.
- Resuspend the cell pellet in a small volume of PBS and add the cells dropwise into ice-cold 70% ethanol while vortexing gently to fix the cells.
- Store the fixed cells at -20°C for at least 2 hours (or overnight).
- Centrifuge the fixed cells and wash with PBS to remove the ethanol.
- Resuspend the cell pellet in a PI staining solution containing RNase A.
- Incubate for 30 minutes at room temperature in the dark.
- Analyze the samples by flow cytometry. The DNA content will be used to determine the percentage of cells in the G0/G1, S, and G2/M phases of the cell cycle.

## Western Blot Analysis

This technique is used to detect and quantify the expression levels of specific proteins involved in the cellular response to TFP.

**Materials:**

- Treated and untreated cell lysates
- Protein assay kit (e.g., BCA assay)
- SDS-PAGE gels
- Electrophoresis and transfer apparatus
- PVDF or nitrocellulose membranes

- Blocking buffer (e.g., 5% non-fat milk or BSA in TBST)
- Primary antibodies against proteins of interest (e.g., cleaved caspase-3, PARP, Cyclin D1, CDK4, p-AKT, AKT)[5][9]
- HRP-conjugated secondary antibodies
- Chemiluminescent substrate
- Imaging system

Procedure:

- Lyse the treated and untreated cells in a suitable lysis buffer containing protease and phosphatase inhibitors.
- Determine the protein concentration of each lysate using a protein assay.
- Denature equal amounts of protein from each sample by boiling in Laemmli buffer.
- Separate the proteins by SDS-PAGE.
- Transfer the separated proteins to a PVDF or nitrocellulose membrane.
- Block the membrane with blocking buffer for 1 hour at room temperature.
- Incubate the membrane with the primary antibody overnight at 4°C.
- Wash the membrane with TBST.
- Incubate the membrane with the appropriate HRP-conjugated secondary antibody for 1 hour at room temperature.
- Wash the membrane again with TBST.
- Add the chemiluminescent substrate and visualize the protein bands using an imaging system.
- Use a loading control (e.g.,  $\beta$ -actin or GAPDH) to normalize protein expression levels.

## Visualization of Cellular Pathways and Workflows

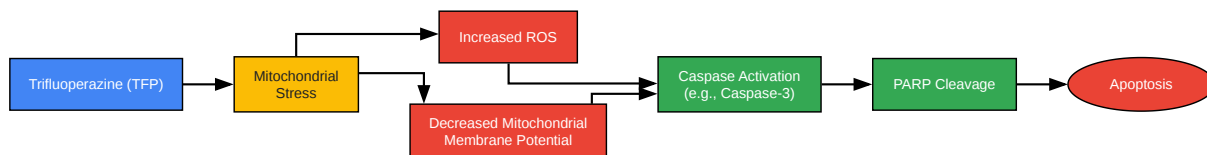

[Click to download full resolution via product page](#)

Caption: TFP-induced intrinsic apoptosis pathway.

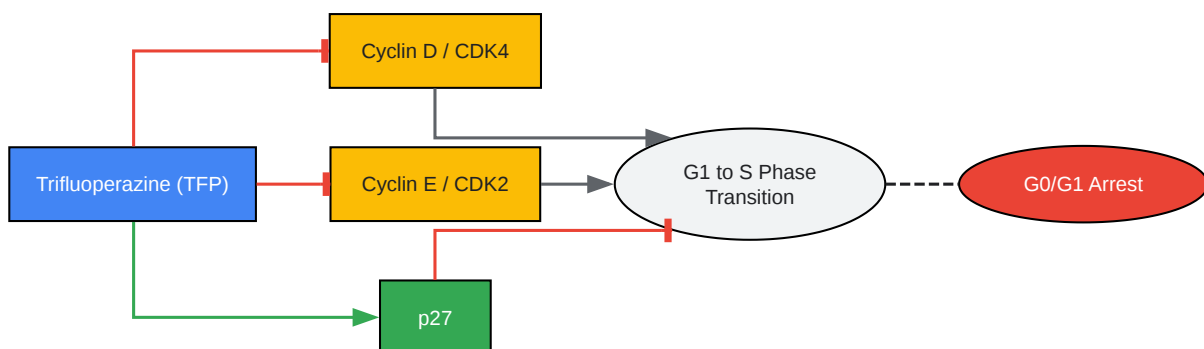

[Click to download full resolution via product page](#)

Caption: TFP-induced G0/G1 cell cycle arrest.

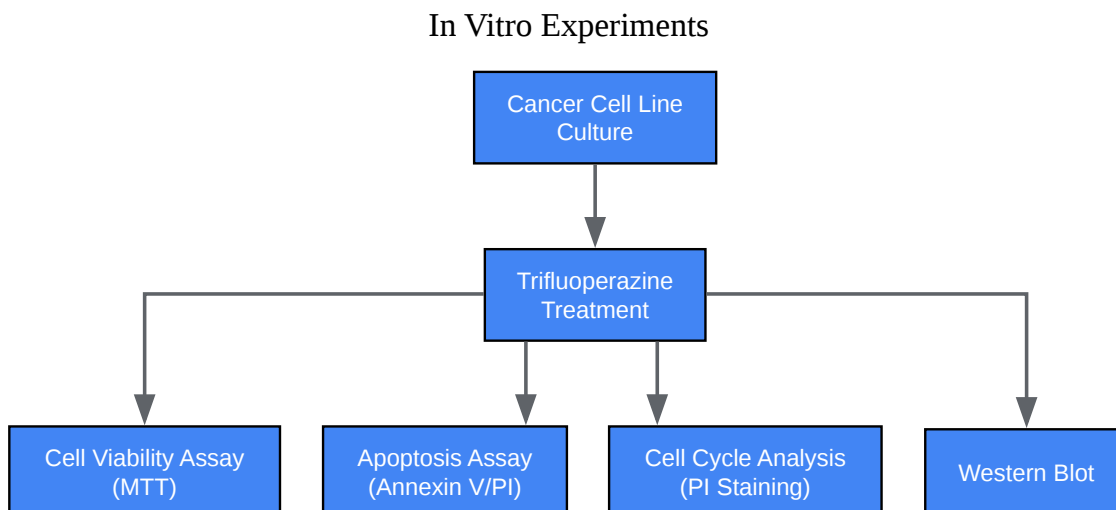

[Click to download full resolution via product page](#)

Caption: General experimental workflow for in vitro studies.

### Need Custom Synthesis?

BenchChem offers custom synthesis for rare earth carbides and specific isotopic labeling.

Email: [info@benchchem.com](mailto:info@benchchem.com) or [Request Quote Online](#).

## References

- 1. Trifluoperazine induces cellular apoptosis by inhibiting autophagy and targeting NUPR1 in multiple myeloma - PMC [[pmc.ncbi.nlm.nih.gov](https://pubmed.ncbi.nlm.nih.gov/)]
- 2. Dissecting the Anticancer Mechanism of Trifluoperazine on Pancreatic Ductal Adenocarcinoma - PMC [[pmc.ncbi.nlm.nih.gov](https://pubmed.ncbi.nlm.nih.gov/)]
- 3. Frontiers | Antipsychotic Drug Trifluoperazine Suppresses Colorectal Cancer by Inducing G0/G1 Arrest and Apoptosis [[frontiersin.org](https://www.frontiersin.org/)]
- 4. The antipsychotic agent trifluoperazine hydrochloride suppresses triple-negative breast cancer tumor growth and brain metastasis by inducing G0/G1 arrest and apoptosis - PubMed [[pubmed.ncbi.nlm.nih.gov](https://pubmed.ncbi.nlm.nih.gov/)]
- 5. [mdpi.com](https://www.mdpi.com/) [[mdpi.com](https://www.mdpi.com/)]

- [6. Antipsychotic Drug Trifluoperazine Suppresses Colorectal Cancer by Inducing G0/G1 Arrest and Apoptosis - PMC \[pmc.ncbi.nlm.nih.gov\]](#)
- [7. Molecular mechanism of trifluoperazine induces apoptosis in human A549 lung adenocarcinoma cell lines - PubMed \[pubmed.ncbi.nlm.nih.gov\]](#)
- [8. Antipsychotic Drug Trifluoperazine Suppresses Colorectal Cancer by Inducing G0/G1 Arrest and Apoptosis - PubMed \[pubmed.ncbi.nlm.nih.gov\]](#)
- [9. Repurposing of the Antipsychotic Trifluoperazine Induces SLC7A11/GPX4- Mediated Ferroptosis of Oral Cancer via the ROS/Autophagy Pathway \[ijbs.com\]](#)
- [10. Trifluoperazine Inhibits Mesangial Cell Proliferation by Arresting Cell Cycle-Dependent Mechanisms - PubMed \[pubmed.ncbi.nlm.nih.gov\]](#)
- [11. researchgate.net \[researchgate.net\]](#)
- [To cite this document: BenchChem. \[Application Notes and Protocols: Utilizing Trifluoperazine Dimaleate in Cancer Cell Line Studies\]. BenchChem, \[2026\]. \[Online PDF\]. Available at: \[https://www.benchchem.com/product/b1239252/docs#application-notes-and-protocols-utilizing-trifluoperazine-dimaleate-in-cancer-cell-line-studies\]](#)

---

### Disclaimer & Data Validity:

The information provided in this document is for Research Use Only (RUO) and is strictly not intended for diagnostic or therapeutic procedures. While BenchChem strives to provide accurate protocols, we make no warranties, express or implied, regarding the fitness of this product for every specific experimental setup.

**Technical Support:** The protocols provided are for reference purposes. Unsure if this reagent suits your experiment?

**Need Industrial/Bulk Grade?** [Request Custom Synthesis Quote](#)

## BenchChem

Our mission is to be the trusted global source of essential and advanced chemicals, empowering scientists and researchers to drive progress in science and industry.

### Contact

Address: 3281 E Guasti Rd

Ontario, CA 91761, United States

Phone: (601) 213-4426

Email: [info@benchchem.com](mailto:info@benchchem.com)

Contact our Ph.D. Support Team for a compatibility check