

interpreting unexpected results from Cbl-b-IN-15 experiments

Author: BenchChem Technical Support Team. **Date:** April 2026

Compound of Interest

Compound Name: Cbl-b-IN-15

Cat. No.: B12389905

[Get Quote](#)

Cbl-b-IN-15 Technical Support Center

Welcome to the technical support resource for **Cbl-b-IN-15**. This guide is designed for researchers, scientists, and drug development professionals to help interpret and troubleshoot unexpected results during their experiments.

Frequently Asked Questions (FAQs)

Q1: What is the primary mechanism of action for **Cbl-b-IN-15**?

A1: **Cbl-b-IN-15** is a small molecule inhibitor that targets the E3 ubiquitin ligase activity of Casitas B-lineage lymphoma-b (Cbl-b).[1][2] Cbl-b negatively regulates T-cell and NK-cell activation by ubiquitinating key signaling proteins, marking them for degradation.[1][3][4] By inhibiting the E3 ligase function of Cbl-b, **Cbl-b-IN-15** is expected to block this degradation, leading to increased activation of immune cells.[1][2]

Q2: In which cell types is **Cbl-b-IN-15** expected to be most active?

A2: Cbl-b is highly expressed in various immune cells, particularly T-cells and Natural Killer (NK) cells.[4][5] Therefore, the most significant effects of **Cbl-b-IN-15** are anticipated in these

cell types. Effects in other immune cells like B-cells and myeloid cells are also possible, as Cbl-b plays a regulatory role in these lineages as well.[4][6]

Q3: What are some known downstream targets of the Cbl-b signaling pathway?

A3: Cbl-b has several known downstream targets involved in regulating immune cell activation. In T-cells, key targets for ubiquitination include proteins in the T-cell receptor (TCR) and CD28 co-stimulatory pathways, such as the p85 subunit of PI3K, Vav1, and PLC- γ 2.[6][7][8] Cbl-b also regulates the stability of SMAD7, a negative regulator of TGF- β signaling.[2][4]

Troubleshooting Unexpected Experimental Results

Scenario 1: No Observed Increase in T-Cell Activation

Question: I have treated activated T-cells with **Cbl-b-IN-15**, but I am not observing the expected increase in proliferation or cytokine production (e.g., IL-2). What could be the issue?

Possible Causes and Troubleshooting Steps:

- Inhibitor Potency and Integrity:
 - Action: Verify the concentration and stability of your **Cbl-b-IN-15** stock. Small molecule inhibitors can degrade over time, especially with improper storage or multiple freeze-thaw cycles.
 - Experiment: Perform a dose-response curve to ensure you are using an effective concentration. Compare your results with the expected IC50 values from the literature, if available.
- Cell Health and Activation Status:
 - Action: Ensure your T-cells are healthy and properly activated. The inhibitory effect of Cbl-b is most prominent in the context of T-cell activation signals.
 - Experiment: Check cell viability using a Trypan Blue exclusion assay or a viability dye with flow cytometry. Confirm T-cell activation by measuring early activation markers like CD69 or CD25 expression via flow cytometry.

- Suboptimal Experimental Conditions:
 - Action: The timing of inhibitor addition relative to T-cell activation can be critical.
 - Experiment: Try pre-incubating the T-cells with **Cbl-b-IN-15** for 1-2 hours before adding the activation stimulus (e.g., anti-CD3/CD28 beads).
- Direct Target Engagement:
 - Action: Confirm that **Cbl-b-IN-15** is engaging its target, Cbl-b, in your cellular context.
 - Experiment: Perform a Western blot to assess the ubiquitination status of a known Cbl-b substrate. A decrease in substrate ubiquitination upon treatment with the inhibitor would confirm target engagement.

Table 1: Example Data for Troubleshooting T-Cell Activation

Condition	T-Cell Proliferation (CFSE Dilution %)	IL-2 Production (pg/mL)	p-Akt (Ser473) Level (Fold Change)
Unstimulated T-cells	< 5%	< 10	1.0
Stimulated T-cells (α CD3/CD28)	60%	500	5.0
Stimulated + Vehicle Control	58%	480	4.8
Expected: Stimulated + Cbl-b-IN-15 (1 μ M)	> 80%	> 800	> 7.0
Unexpected: Stimulated + Cbl-b-IN-15 (1 μ M)	62%	510	5.1

Scenario 2: Unexpected Cytotoxicity

Question: I am observing significant cell death at concentrations of **Cbl-b-IN-15** that are supposed to be non-toxic. Why is this happening?

Possible Causes and Troubleshooting Steps:

- Off-Target Effects:
 - Action: At higher concentrations, small molecule inhibitors can have off-target effects that may lead to cytotoxicity.[\[9\]](#)
 - Experiment: Perform a comprehensive dose-response analysis for cytotoxicity using a sensitive assay (e.g., Annexin V/PI staining by flow cytometry). Determine the concentration at which toxicity is observed and compare it to the effective concentration for Cbl-b inhibition. Use the lowest effective concentration in your experiments.[\[10\]](#)
- Solvent Toxicity:
 - Action: The vehicle used to dissolve **Cbl-b-IN-15** (e.g., DMSO) can be toxic to cells at certain concentrations.
 - Experiment: Include a vehicle-only control at the same final concentration used in your experimental conditions to assess the toxicity of the solvent itself.
- Cell Line Sensitivity:
 - Action: Different cell lines or primary cell types can have varying sensitivities to chemical compounds.
 - Experiment: If possible, test the inhibitor on a different cell line known to be responsive to Cbl-b inhibition to see if the cytotoxicity is cell-type specific.

Table 2: Example Data for Assessing Cytotoxicity

Condition	Concentration (μM)	Cell Viability (%)	Apoptosis (Annexin V+ %)
Untreated Control	0	98%	< 5%
Vehicle Control (0.1% DMSO)	N/A	97%	< 5%
Cbl-b-IN-15	0.1	96%	< 5%
Cbl-b-IN-15	1.0	95%	6%
Unexpected: Cbl-b-IN-15	10.0	60%	35%
Unexpected: Cbl-b-IN-15	50.0	25%	70%

Experimental Protocols

Protocol 1: Western Blot for Phosphorylated Akt (p-Akt)

This protocol is used to assess the activation of the PI3K/Akt pathway, which is negatively regulated by Cbl-b. Inhibition of Cbl-b is expected to increase Akt phosphorylation.

- Cell Treatment: Plate 2×10^6 T-cells per well. Pre-treat with **Cbl-b-IN-15** or vehicle for 1 hour.
- Cell Stimulation: Stimulate cells with anti-CD3/CD28 antibodies for 15 minutes.
- Lysis: Pellet cells and lyse in RIPA buffer containing protease and phosphatase inhibitors.
- Quantification: Determine protein concentration using a BCA assay.
- SDS-PAGE: Load 20 μg of protein per lane onto a 10% polyacrylamide gel.
- Transfer: Transfer proteins to a PVDF membrane.
- Blocking: Block the membrane with 5% BSA in TBST for 1 hour at room temperature.

- Primary Antibody Incubation: Incubate with primary antibodies against p-Akt (Ser473), total Akt, and a loading control (e.g., GAPDH) overnight at 4°C.
- Secondary Antibody Incubation: Wash the membrane and incubate with HRP-conjugated secondary antibodies for 1 hour at room temperature.
- Detection: Visualize bands using an ECL substrate and an imaging system. Quantify band intensity using densitometry software.

Protocol 2: In Vitro Cbl-b Autoubiquitination Assay

This biochemical assay directly measures the E3 ligase activity of Cbl-b and can be used to confirm the inhibitory action of **Cbl-b-IN-15**.[\[11\]](#)

- Reaction Setup: In a microcentrifuge tube, combine the following components:
 - Recombinant E1 activating enzyme (100 nM)
 - Recombinant E2 conjugating enzyme (UbcH5b, 500 nM)
 - Biotinylated-Ubiquitin (5 μM)
 - Recombinant Cbl-b (200 nM)
 - ATP (2 mM)
 - Varying concentrations of **Cbl-b-IN-15** or vehicle control.
 - Assay buffer to final volume.
- Incubation: Incubate the reaction mixture at 37°C for 60 minutes.
- Quenching: Stop the reaction by adding SDS-PAGE loading buffer.
- Western Blot Analysis:
 - Run the samples on an SDS-PAGE gel and transfer to a PVDF membrane.
 - Probe the membrane with Streptavidin-HRP to detect biotinylated-ubiquitin.

- The appearance of high molecular weight smears or bands indicates polyubiquitinated Cbl-b.
- Analysis: A potent inhibitor will show a dose-dependent decrease in the ubiquitination signal.

Visualizations

Signaling Pathways and Workflows

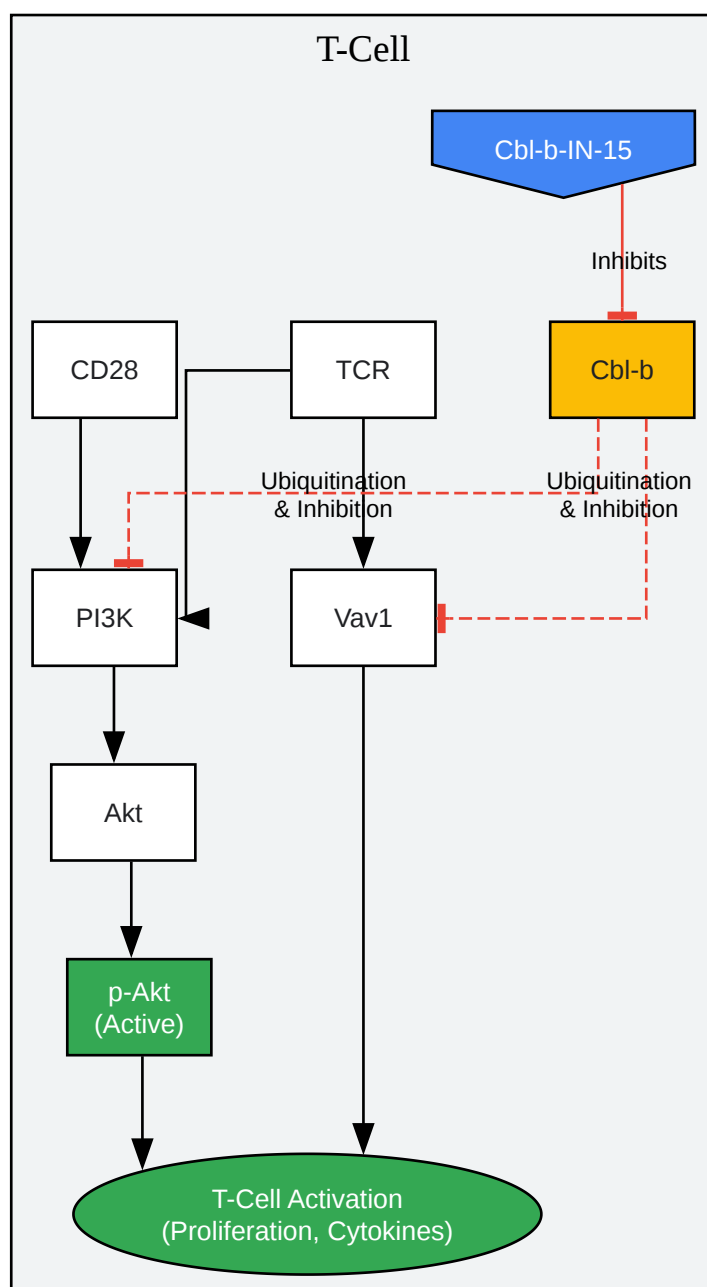

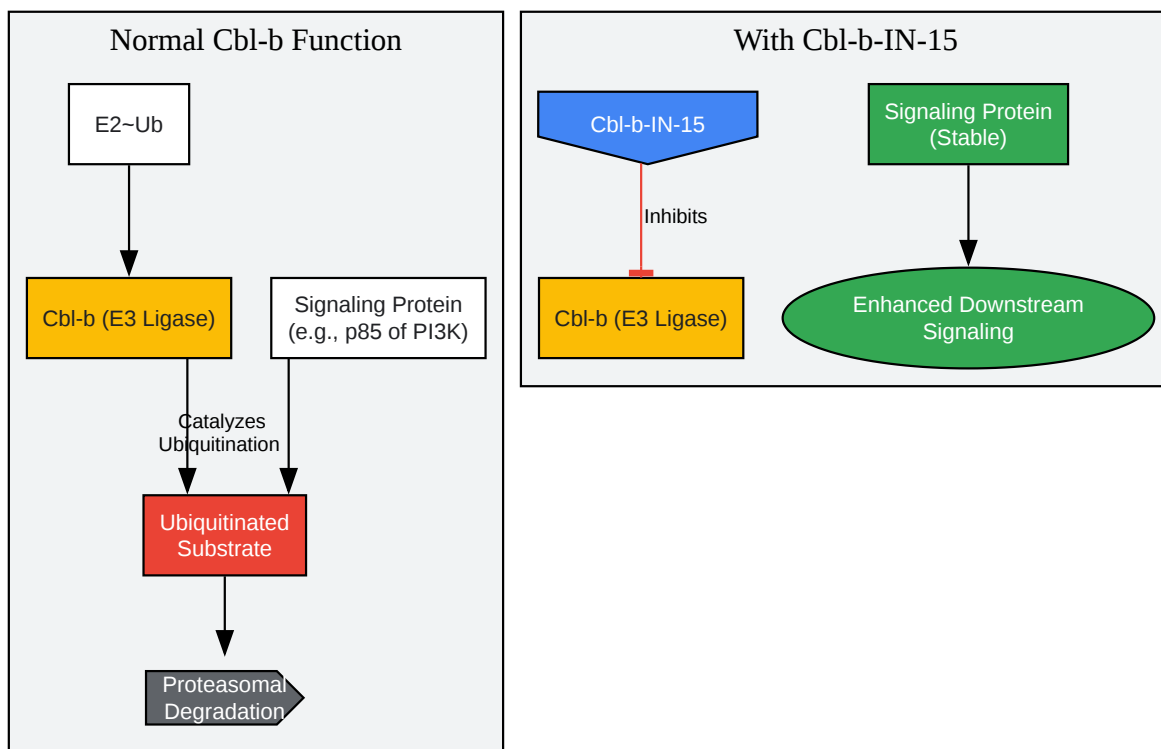

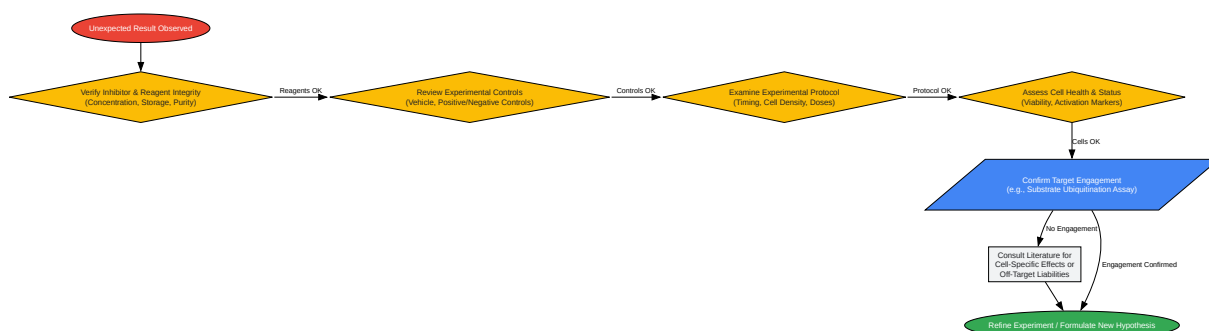

[Click to download full resolution via product page](#)

Need Custom Synthesis?

BenchChem offers custom synthesis for rare earth carbides and specific isotopic labeling.

Email: info@benchchem.com or [Request Quote Online](#).

References

- 1. What are Cbl-b inhibitors and how do they work? [synapse.patsnap.com]
- 2. jitc.bmj.com [jitc.bmj.com]

- [3. bpsbioscience.com \[bpsbioscience.com\]](https://bpsbioscience.com)
- [4. Frontiers | Modulation of Immune Cell Functions by the E3 Ligase Cbl-b \[frontiersin.org\]](https://www.frontiersin.org)
- [5. Cbl-b is upregulated and plays a negative role in activated human NK cells - PMC \[pmc.ncbi.nlm.nih.gov\]](https://pubmed.ncbi.nlm.nih.gov)
- [6. E3 ubiquitin ligase Cbl-b in innate and adaptive immunity - PMC \[pmc.ncbi.nlm.nih.gov\]](https://pubmed.ncbi.nlm.nih.gov)
- [7. c-Cbl and Cbl-b ubiquitin ligases: substrate diversity and the negative regulation of signalling responses - PMC \[pmc.ncbi.nlm.nih.gov\]](https://pubmed.ncbi.nlm.nih.gov)
- [8. aacrjournals.org \[aacrjournals.org\]](https://aacrjournals.org)
- [9. PROTACs to Address the Challenges Facing Small Molecule Inhibitors - PMC \[pmc.ncbi.nlm.nih.gov\]](https://pubmed.ncbi.nlm.nih.gov)
- [10. resources.biomol.com \[resources.biomol.com\]](https://resources.biomol.com)
- [11. promega.com \[promega.com\]](https://promega.com)
- To cite this document: BenchChem. [interpreting unexpected results from Cbl-b-IN-15 experiments]. BenchChem, [2026]. [Online PDF]. Available at: [\[https://www.benchchem.com/product/b12389905/docs#interpreting-unexpected-results-from-cbl-b-in-15-experiments\]](https://www.benchchem.com/product/b12389905/docs#interpreting-unexpected-results-from-cbl-b-in-15-experiments)

Disclaimer & Data Validity:

The information provided in this document is for Research Use Only (RUO) and is strictly not intended for diagnostic or therapeutic procedures. While BenchChem strives to provide accurate protocols, we make no warranties, express or implied, regarding the fitness of this product for every specific experimental setup.

Technical Support: The protocols provided are for reference purposes. Unsure if this reagent suits your experiment?

Need Industrial/Bulk Grade? [Request Custom Synthesis Quote](#)

BenchChem

Our mission is to be the trusted global source of essential and advanced chemicals, empowering scientists and researchers to drive progress in science and industry.

Contact

Address: 3281 E Guasti Rd

Ontario, CA 91761, United States

Phone: (601) 213-4426

Email: info@benchchem.com

[Contact our Ph.D. Support Team for a compatibility check](#)