

# PV-1019 assay interference and mitigation

**Author:** BenchChem Technical Support Team. **Date:** April 2026

## Compound of Interest

Compound Name: PV-1019  
Cat. No.: B12389911

[Get Quote](#)

## PV-1019 Technical Support Center

This technical support center provides troubleshooting guides and frequently asked questions (FAQs) for researchers, scientists, and drug development professionals working with **PV-1019**, a potent and selective Chk2 inhibitor.

### Frequently Asked Questions (FAQs)

Q1: What is **PV-1019** and what is its primary mechanism of action?

**PV-1019** is a potent and selective inhibitor of Checkpoint Kinase 2 (Chk2), a key protein in the DNA damage response pathway.<sup>[1][2]</sup> It functions as an ATP-competitive inhibitor, binding to the ATP pocket of Chk2 and preventing its kinase activity.<sup>[1][2][3]</sup> This inhibition prevents the autophosphorylation of Chk2 and the subsequent phosphorylation of its downstream targets, such as Cdc25C, which can lead to cell cycle arrest and apoptosis.<sup>[1][2][4]</sup>

Q2: What are the common assays used to measure the activity of **PV-1019**?

Common assays to evaluate **PV-1019** activity include:

- In vitro kinase assays: To determine the direct inhibitory effect on Chk2 activity, often using a substrate like histone H1 or a specific peptide.

- Western Blot analysis: To measure the inhibition of Chk2 autophosphorylation (e.g., at Ser516) and the phosphorylation of downstream targets like Cdc25C in cell lysates.[4][5]
- Cell viability and proliferation assays: To assess the antiproliferative effects of **PV-1019**, alone or in combination with DNA damaging agents.[5]
- Apoptosis assays: To determine the induction of apoptosis, for instance by measuring the sub-G1 cell population via flow cytometry.[5]

Q3: What are the reported IC50 values for **PV-1019**?

The IC50 value for **PV-1019** can vary depending on the assay conditions. Reported values include:

- 24 nM for Chk2 inhibition in a cell-free kinase assay.[3][5]
- 138 nM for inhibiting Chk2 autophosphorylation and histone H1 phosphorylation.[5]
- 260 nM for inhibiting Chk2-dependent phosphorylation of Cdc25C.[3]
- 2.8  $\mu$ M for inhibiting topotecan-induced Chk2 autophosphorylation in OVCAR-5 cells.[5]

## Troubleshooting Guides

### Issue 1: Inconsistent IC50 values in in vitro kinase assays.

Possible Cause 1: High ATP Concentration. Since **PV-1019** is an ATP-competitive inhibitor, high concentrations of ATP in the kinase assay reaction can compete with **PV-1019** binding and lead to an overestimation of the IC50 value.[2][3]

Mitigation Strategy:

- Optimize ATP Concentration: Use an ATP concentration that is at or near the Km for Chk2. This will ensure that the assay is sensitive to competitive inhibition.
- Control Consistency: Ensure the ATP concentration is consistent across all experiments and all wells of an assay plate.

Possible Cause 2: Reagent Instability. **PV-1019**, like many small molecules, may be sensitive to storage conditions and freeze-thaw cycles.

Mitigation Strategy:

- Proper Storage: Store **PV-1019** as a powder at -20°C for long-term storage (up to 3 years). In solvent, store at -80°C for up to 6 months or at -20°C for up to 1 month.[5]
- Aliquoting: Prepare single-use aliquots of **PV-1019** solutions to minimize freeze-thaw cycles.

## Issue 2: Weak or no inhibition of Chk2 autophosphorylation in cellular assays.

Possible Cause 1: Insufficient DNA Damage. Chk2 is activated in response to DNA damage. If the DNA damaging agent (e.g., topotecan, ionizing radiation) is not used at a sufficient concentration or for a sufficient duration, Chk2 activation will be minimal, and the inhibitory effect of **PV-1019** will not be apparent.

Mitigation Strategy:

- Titrate DNA Damaging Agent: Perform a dose-response and time-course experiment with the DNA damaging agent to determine the optimal conditions for robust Chk2 autophosphorylation.
- Positive Controls: Include a positive control with a known inducer of Chk2 phosphorylation to ensure the cellular system is responsive.

Possible Cause 2: Cell Line Resistance. Different cell lines may have varying levels of Chk2 expression or may have alterations in the DNA damage response pathway that make them less sensitive to Chk2 inhibition.

Mitigation Strategy:

- Cell Line Screening: Test **PV-1019** in a panel of cell lines to identify those with a sensitive phenotype. The NCI-60 screen has been used to identify cancer cells with high Chk2 expression that are sensitive to **PV-1019**. [2]

- Characterize Cell Lines: Before extensive experiments, confirm Chk2 expression levels in your chosen cell line via Western Blot or other methods.

### Issue 3: High background or false positives in immunogenicity assays.

While specific interference for **PV-1019** is not documented, general principles of assay interference can be applied. Soluble drug targets can sometimes interfere with anti-drug antibody (ADA) bridging assays, leading to false-positive results.[\[6\]](#)[\[7\]](#)[\[8\]](#)[\[9\]](#)

**Possible Cause:** Presence of soluble drug targets in samples. In the context of biotherapeutics, soluble targets can cross-link assay reagents. While less common for small molecules like **PV-1019**, interactions with cellular components could theoretically cause interference.

**Mitigation Strategy:**

- **Sample Dilution:** Diluting the sample can sometimes reduce the concentration of the interfering substance below the level of detection.
- **Use of Blocking Agents:** The addition of anti-target antibodies or other blocking reagents can sequester the interfering substance.[\[6\]](#)[\[7\]](#)
- **Adjusting Assay pH:** Modifying the pH of the assay buffer can sometimes disrupt the interactions causing the interference.[\[6\]](#)

## Quantitative Data Summary

Parameter	Value	Assay Conditions	Reference
IC50 (Chk2 inhibition)	24 nM	Cell-free kinase assay	[3][5]
IC50 (Chk2 autophosphorylation)	138 nM	In vitro	[5]
IC50 (Cdc25C phosphorylation)	260 nM	In vitro	[3]
IC50 (Topotecan-induced Chk2 autophosphorylation)	2.8 $\mu$ M	OVCAR-5 cells	[5]

## Experimental Protocols

### Protocol 1: In Vitro Chk2 Kinase Assay

- Prepare Reagents:
  - Chk2 enzyme
  - Kinase buffer (containing MgCl<sub>2</sub> and ATP)
  - Substrate (e.g., Histone H1 or a specific peptide)
  - **PV-1019** serial dilutions
  - Detection reagent (e.g., ADP-Glo™ Kinase Assay)
- Assay Procedure:
  - Add kinase buffer, Chk2 enzyme, and substrate to a 96-well plate.
  - Add serial dilutions of **PV-1019** or vehicle control.
  - Initiate the reaction by adding ATP.
  - Incubate at 30°C for the desired time (e.g., 60 minutes).

- Stop the reaction and measure the kinase activity using the detection reagent according to the manufacturer's instructions.
- Data Analysis:
  - Plot the percentage of inhibition against the log concentration of **PV-1019**.
  - Calculate the IC50 value using a non-linear regression curve fit.

## Protocol 2: Western Blot for Chk2 Phosphorylation in Cells

- Cell Culture and Treatment:
  - Plate cells (e.g., OVCAR-5) and allow them to adhere overnight.
  - Pre-treat cells with various concentrations of **PV-1019** for 1 hour.[5]
  - Induce DNA damage by adding a DNA damaging agent (e.g., topotecan) and incubate for the desired time.
- Cell Lysis:
  - Wash cells with ice-cold PBS.
  - Lyse cells in RIPA buffer supplemented with protease and phosphatase inhibitors.
  - Clarify the lysate by centrifugation.
- Protein Quantification and Electrophoresis:
  - Determine the protein concentration of the lysates using a BCA assay.
  - Denature equal amounts of protein by boiling in Laemmli buffer.
  - Separate proteins by SDS-PAGE.
- Western Blotting:

- Transfer proteins to a PVDF membrane.
- Block the membrane with 5% non-fat milk or BSA in TBST.
- Incubate the membrane with a primary antibody against phospho-Chk2 (Ser516).
- Wash the membrane and incubate with an HRP-conjugated secondary antibody.
- Detect the signal using an enhanced chemiluminescence (ECL) substrate.
- Strip the membrane and re-probe for total Chk2 and a loading control (e.g., GAPDH).

## Visualizations

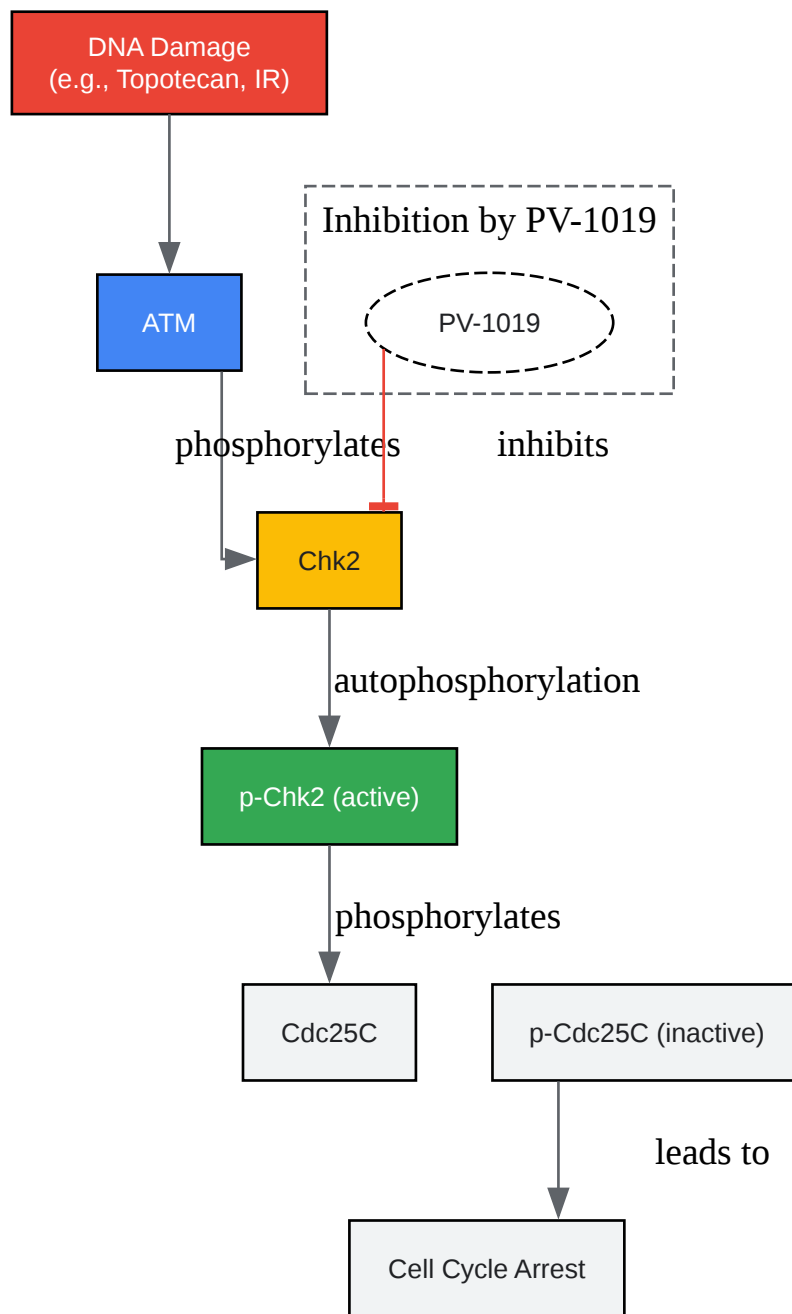

[Click to download full resolution via product page](#)

Caption: **PV-1019** inhibits the Chk2 signaling pathway.



[Click to download full resolution via product page](#)

Caption: Workflow for Western Blot analysis of Chk2 phosphorylation.

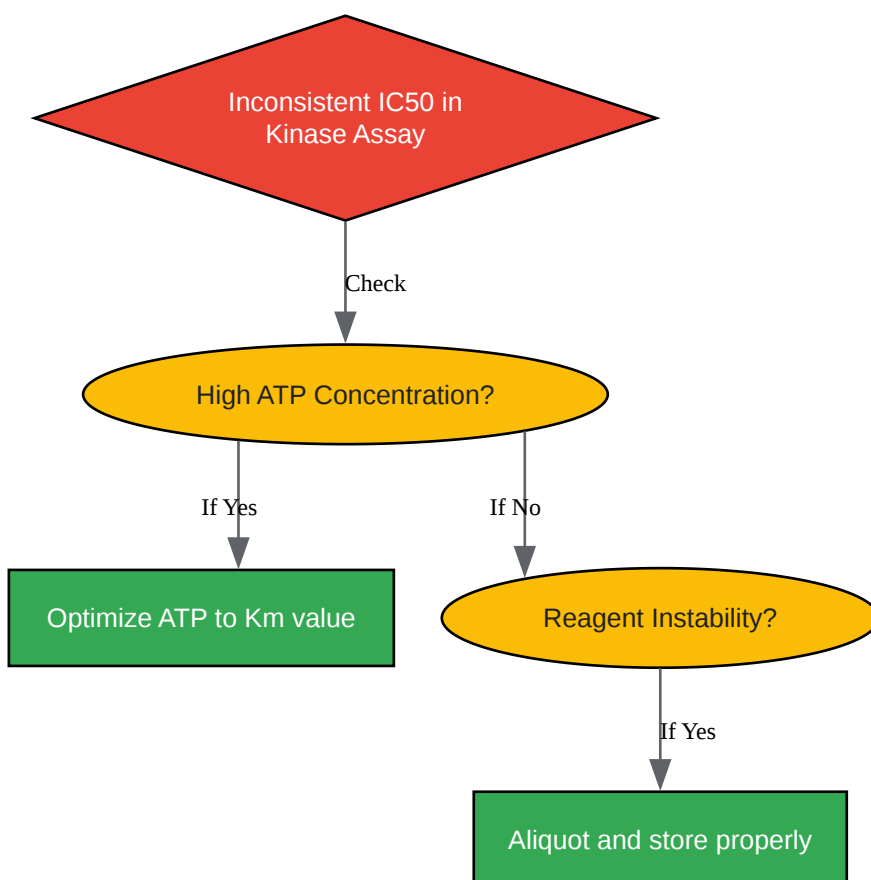

[Click to download full resolution via product page](#)

Caption: Troubleshooting logic for inconsistent kinase assay results.

### Need Custom Synthesis?

BenchChem offers custom synthesis for rare earth carbides and specific isotopic labeling.

Email: [info@benchchem.com](mailto:info@benchchem.com) or [Request Quote Online](#).

## References

- 1. PV-1019 - Drug Targets, Indications, Patents - Synapse [[synapse.patsnap.com](http://synapse.patsnap.com)]

- 2. Cellular inhibition of checkpoint kinase 2 (Chk2) and potentiation of camptothecins and radiation by the novel Chk2 inhibitor PV1019 [7-nitro-1H-indole-2-carboxylic acid {4-[1-(guanidinohydrazono)-ethyl]-phenyl}-amide] - PubMed [pubmed.ncbi.nlm.nih.gov]
- 3. researchgate.net [researchgate.net]
- 4. researchgate.net [researchgate.net]
- 5. medchemexpress.com [medchemexpress.com]
- 6. Mitigating target interference in bridging immunogenicity assay with target-blocking reagents and mild basic pH - PubMed [pubmed.ncbi.nlm.nih.gov]
- 7. researchgate.net [researchgate.net]
- 8. Mitigating target interference challenges in bridging immunogenicity assay to detect anti-tocilizumab antibodies - PMC [pmc.ncbi.nlm.nih.gov]
- 9. Drug Target Interference in Immunogenicity Assays: Recommendations and Mitigation Strategies - PubMed [pubmed.ncbi.nlm.nih.gov]
- To cite this document: BenchChem. [PV-1019 assay interference and mitigation]. BenchChem, [2026]. [Online PDF]. Available at: [https://www.benchchem.com/product/b12389911/docs#pv-1019-assay-interference-and-mitigation]

---

### Disclaimer & Data Validity:

The information provided in this document is for Research Use Only (RUO) and is strictly not intended for diagnostic or therapeutic procedures. While BenchChem strives to provide accurate protocols, we make no warranties, express or implied, regarding the fitness of this product for every specific experimental setup.

**Technical Support:** The protocols provided are for reference purposes. Unsure if this reagent suits your experiment?

**Need Industrial/Bulk Grade?** [Request Custom Synthesis Quote](#)

# BenchChem

Our mission is to be the trusted global source of essential and advanced chemicals, empowering scientists and researchers to drive progress in science and industry.

## Contact

Address: 3281 E Guasti Rd

Ontario, CA 91761, United States

Phone: (601) 213-4426

Email: [info@benchchem.com](mailto:info@benchchem.com)

[Contact our Ph.D. Support Team for a compatibility check](#)