

# Application Note: Cbl-b-IN-15 T Cell Proliferation Assay

**Author:** BenchChem Technical Support Team. **Date:** April 2026

## Compound of Interest

Compound Name: Cbl-b-IN-15

Cat. No.: B12389905

[Get Quote](#)

Audience: Researchers, scientists, and drug development professionals.

## Introduction

Casitas B-lineage lymphoma-b (Cbl-b) is an E3 ubiquitin ligase that functions as a critical intracellular immune checkpoint, negatively regulating T cell activation, proliferation, and anti-tumor immunity.[1][2][3] It acts as a gatekeeper, setting the threshold for T cell activation and enforcing the need for co-stimulatory signals, such as through CD28.[4][5] By ubiquitinating key components of the T cell receptor (TCR) signaling pathway, Cbl-b attenuates downstream signals, leading to immune tolerance.[6][7] Inhibition of Cbl-b has emerged as a promising therapeutic strategy in immuno-oncology to enhance T cell effector functions.[3][8] **Cbl-b-IN-15** is a small molecule inhibitor designed to target Cbl-b, thereby lowering the T cell activation threshold and promoting a robust anti-tumor immune response.[9]

This application note provides a detailed protocol for assessing the effect of **Cbl-b-IN-15** on T cell proliferation using a Carboxyfluorescein Succinimidyl Ester (CFSE) dilution assay, a standard method for tracking cell divisions via flow cytometry.[10]

## Cbl-b Signaling Pathway in T Cell Activation

Upon engagement of the T Cell Receptor (TCR) and the co-stimulatory receptor CD28, a signaling cascade is initiated, leading to T cell activation and proliferation. Cbl-b acts as a negative regulator in this pathway by targeting key signaling proteins like Phospholipase C gamma 1 (PLCγ1) and the p85 subunit of Phosphoinositide 3-kinase (PI3K) for ubiquitination and degradation.[3][6][11] The inhibitor **Cbl-b-IN-15** blocks this E3 ligase activity, preventing the degradation of these signaling molecules. This leads to sustained downstream signaling through pathways like MAPK/ERK and PI3K/Akt, resulting in enhanced T cell activation, cytokine production (e.g., IL-2), and proliferation.[3][12]

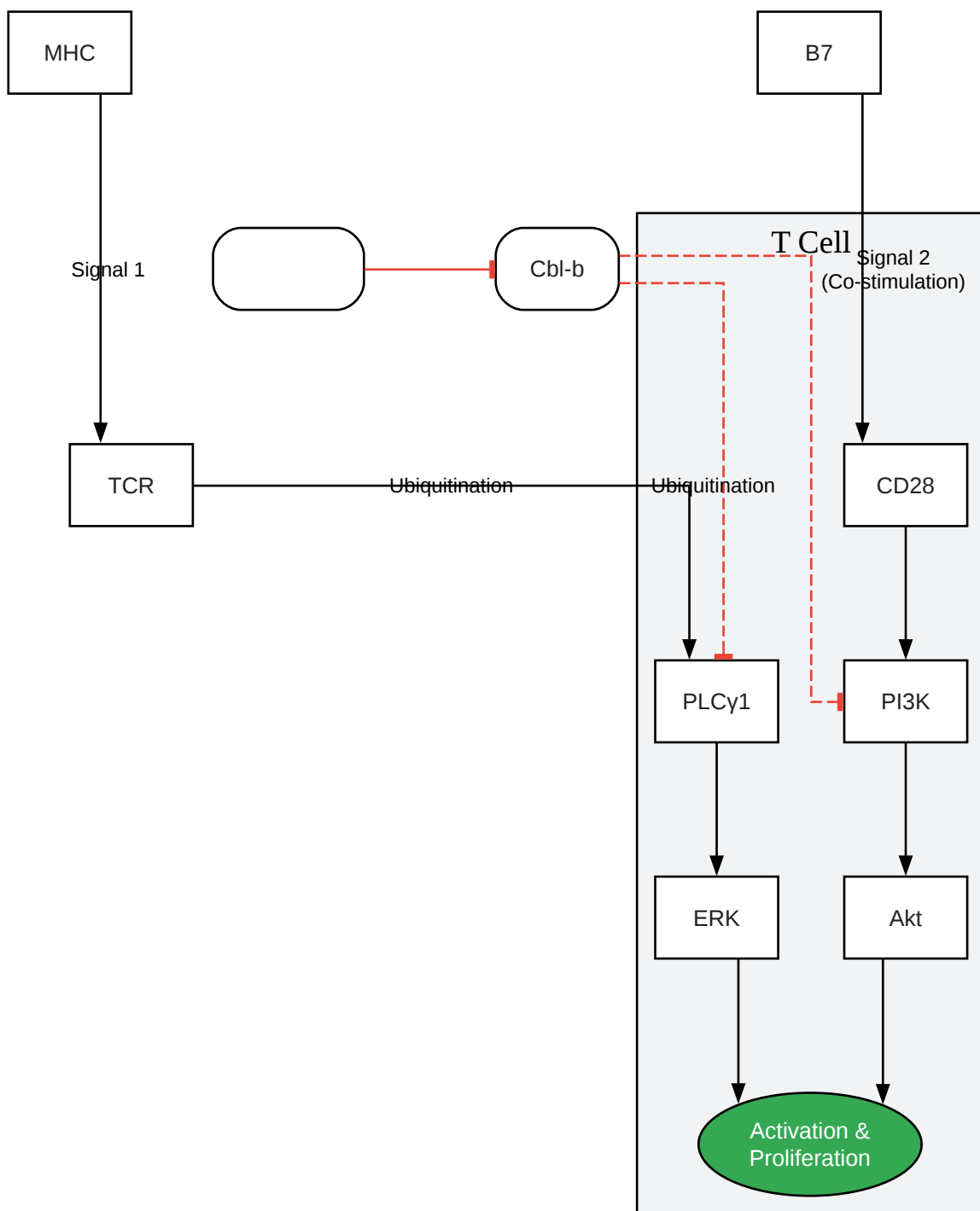

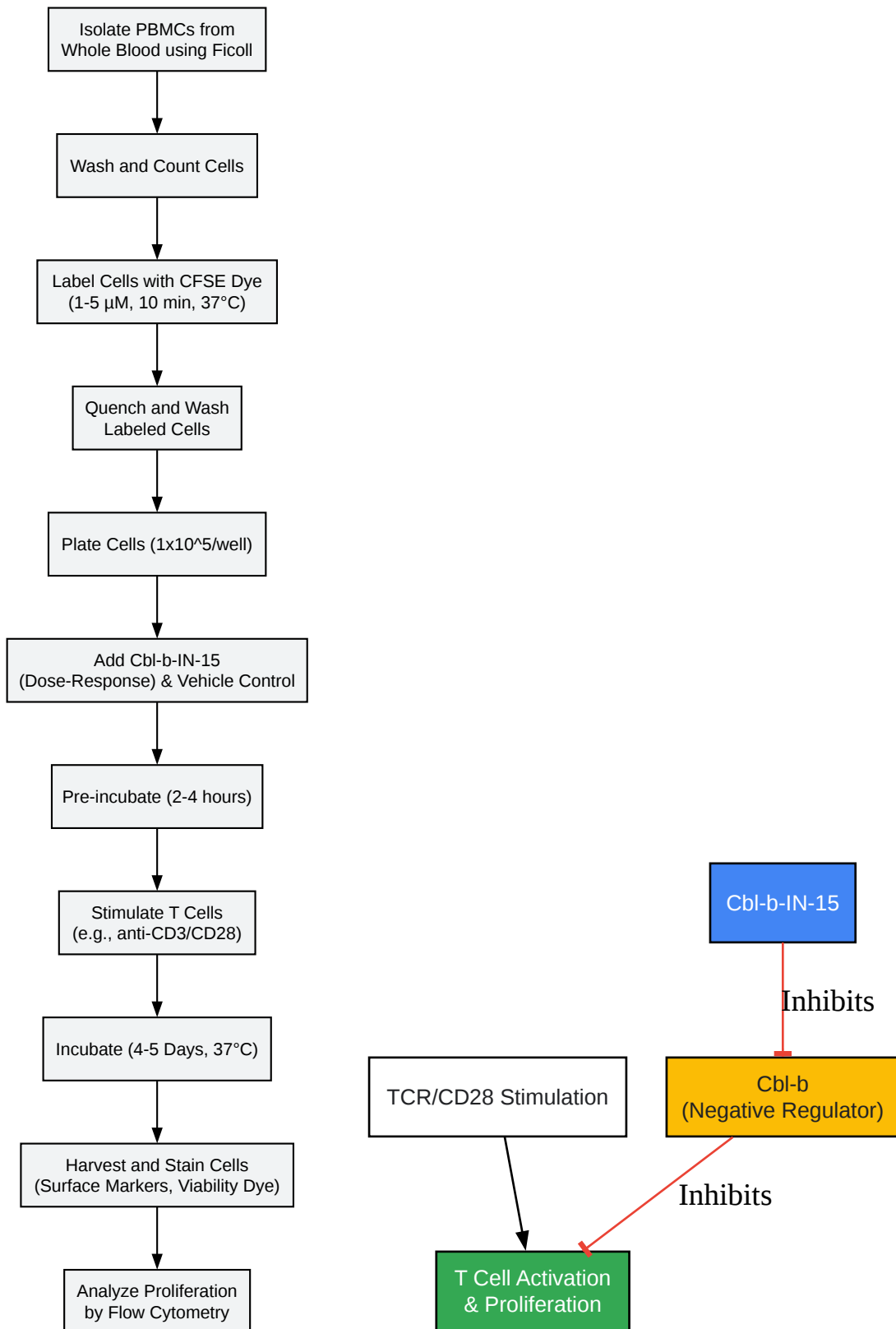

[Click to download full resolution via product page](#)

**Need Custom Synthesis?**

BenchChem offers custom synthesis for rare earth carbides and specific isotopic labeling.

Email: [info@benchchem.com](mailto:info@benchchem.com) or [Request Quote Online](#).

## References

- [1. jtc.bmj.com](http://jtc.bmj.com) [jtc.bmj.com]
- [2. Frontiers | Modulation of Immune Cell Functions by the E3 Ligase Cbl-b](http://frontiersin.org) [frontiersin.org]
- [3. jtc.bmj.com](http://jtc.bmj.com) [jtc.bmj.com]
- [4. researchgate.net](http://researchgate.net) [researchgate.net]
- [5. Cbl-b in T-cell activation - PubMed](http://pubmed.ncbi.nlm.nih.gov) [pubmed.ncbi.nlm.nih.gov]
- [6. Mechanisms of Cbl-Mediated Ubiquitination of Proteins in T and Natural Killer Cells and Effects on Immune Cell Functions - PMC](http://pmc.ncbi.nlm.nih.gov) [pmc.ncbi.nlm.nih.gov]
- [7. researchgate.net](http://researchgate.net) [researchgate.net]
- [8. investing.com](http://investing.com) [investing.com]
- [9. nurixtx.com](http://nurixtx.com) [nurixtx.com]
- [10. CFSE dilution to study human T and NK cell proliferation in vitro - PubMed](http://pubmed.ncbi.nlm.nih.gov) [pubmed.ncbi.nlm.nih.gov]
- [11. Cbl-b: Roles in T Cell Tolerance, Proallergic T Cell Development, and Cancer Immunity - PMC](http://pmc.ncbi.nlm.nih.gov) [pmc.ncbi.nlm.nih.gov]
- [12. ohiostate.elsevierpure.com](http://ohiostate.elsevierpure.com) [ohiostate.elsevierpure.com]
- To cite this document: BenchChem. [Application Note: Cbl-b-IN-15 T Cell Proliferation Assay]. BenchChem, [2026]. [Online PDF]. Available at: [\[https://www.benchchem.com/product/b12389905/docs#application-note-cbl-b-in-15-t-cell-proliferation-assay\]](https://www.benchchem.com/product/b12389905/docs#application-note-cbl-b-in-15-t-cell-proliferation-assay)

---

**Disclaimer & Data Validity:**

The information provided in this document is for Research Use Only (RUO) and is strictly not intended for diagnostic or therapeutic procedures. While BenchChem strives to provide

accurate protocols, we make no warranties, express or implied, regarding the fitness of this product for every specific experimental setup.

**Technical Support:** The protocols provided are for reference purposes. Unsure if this reagent suits your experiment?

**Need Industrial/Bulk Grade?** [Request Custom Synthesis Quote](#)

## BenchChem

Our mission is to be the trusted global source of essential and advanced chemicals, empowering scientists and researchers to drive progress in science and industry.

### Contact

Address: 3281 E Guasti Rd  
Ontario, CA 91761, United States  
Phone: (601) 213-4426  
Email: [info@benchchem.com](mailto:info@benchchem.com)

[Contact our Ph.D. Support Team for a compatibility check](#)