

# Technical Support Center: Enhancing Thermoelectric Generator (TEG) Efficiency

**Author:** BenchChem Technical Support Team. **Date:** April 2026

## Compound of Interest

Compound Name: G43-C3-TEG

Cat. No.: B12388539

[Get Quote](#)

This technical support center provides researchers, scientists, and drug development professionals with comprehensive troubleshooting guides and frequently asked questions (FAQs) to address common challenges encountered during thermoelectric generator (TEG) experimentation. Our goal is to help you optimize your experimental setup and improve the overall efficiency of your thermoelectric systems.

## Troubleshooting Guide

This guide is designed to help you diagnose and resolve common issues that may arise during your TEG experiments, leading to improved efficiency and more accurate results.

**Question:** Why is the measured power output of my TEG significantly lower than the manufacturer's specifications?

**Answer:**

Several factors can contribute to a lower-than-expected power output. Follow these troubleshooting steps to identify and address the root cause:

- Inadequate Temperature Differential ( $\Delta T$ ): The power output of a TEG is directly proportional to the square of the temperature difference across it.
  - Verification: Use thermocouples to accurately measure the hot-side ( $T_h$ ) and cold-side ( $T_c$ ) temperatures directly on the surfaces of the TEG module. Do not rely on the setpoints of your heating or cooling equipment.
  - Solution:
    - Improve the thermal contact between the heat source/sink and the TEG module using thermal grease or graphite sheets.
    - Ensure your heat source can supply sufficient thermal energy and that your heat sink can effectively dissipate heat. For high-power applications, consider active cooling solutions like fans or liquid cooling.[1]
- High Thermal and Electrical Contact Resistance: Poor contact at the interfaces between the TEG and the hot/cold plates can significantly impede performance.
  - Verification: This is often diagnosed by observing a large temperature drop between the heat source/sink and the TEG surface. Simulations that exclude contact resistances will significantly over-predict both heat flow and power output.[2]
  - Solution:
    - Ensure uniform and adequate clamping pressure across the module's surface. Uneven pressure can lead to poor thermal contact and even damage the module. A clamping pressure of 8.0 kg/cm<sup>2</sup> to 9.6 kg/cm<sup>2</sup> has been shown to be sufficient in some cases.
    - Use high-quality thermal interface materials (TIMs) to fill microscopic gaps between surfaces.
- Impedance Mismatch: Maximum power is transferred from the TEG to the external load when the load resistance ( $R_L$ ) matches the internal resistance ( $R_{TEG}$ ) of the generator.
  - Verification: Measure the internal resistance of your TEG module. Then, measure the resistance of your external load.

- Solution: Adjust the external load resistance to match the TEG's internal resistance. This can be achieved using a variable resistor or a maximum power point tracking (MPPT) system for dynamic loads.
- Material Degradation: Prolonged exposure to high temperatures, especially beyond the material's recommended operating range, can lead to degradation of the thermoelectric material's properties.
  - Verification: This can be difficult to assess without specialized equipment. Signs include a gradual and irreversible decline in performance under consistent operating conditions.
  - Solution: Operate the TEG within its specified temperature limits. For high-temperature applications, select materials with high thermal stability.

Question: My TEG's performance is inconsistent across different experiments, even under seemingly identical conditions. What could be the cause?

Answer:

Inconsistent performance is often due to subtle variations in the experimental setup. Consider the following:

- Non-Uniform Temperature Distribution: Hot or cold spots across the surface of the TEG can lead to suboptimal performance.
  - Verification: Use multiple thermocouples or an infrared camera to map the temperature distribution on both the hot and cold sides of the module.
  - Solution: Redesign your heating and cooling blocks to ensure a more uniform temperature distribution. For fluid-based heat exchangers, ensure proper flow distribution.
- Variable Clamping Pressure: Inconsistent application of pressure between experiments can alter the thermal contact resistance.
  - Solution: Use a torque wrench or a pressure sensor to apply a consistent and measurable clamping force for every experiment.

- Ambient Temperature Fluctuations: Changes in the ambient temperature can affect the performance of the cold-side heat sink, thereby altering the temperature differential.
  - Solution: Conduct experiments in a temperature-controlled environment. If this is not possible, record the ambient temperature for each experiment and consider it in your analysis.

## Frequently Asked Questions (FAQs)

Q1: How can I improve the intrinsic efficiency of my thermoelectric material?

A1: The efficiency of a thermoelectric material is quantified by its dimensionless figure of merit, ZT, where  $ZT = (S^2\sigma T)/\kappa$ .<sup>[3][4]</sup> Here, S is the Seebeck coefficient,  $\sigma$  is the electrical conductivity, T is the absolute temperature, and  $\kappa$  is the thermal conductivity. To improve ZT, one must:

- Increase the Seebeck Coefficient (S): This enhances the voltage generated for a given temperature difference.
- Increase the Electrical Conductivity ( $\sigma$ ): This minimizes Joule heating losses.
- Decrease the Thermal Conductivity ( $\kappa$ ): This helps maintain a large temperature gradient across the device.<sup>[4]</sup>

Strategies to achieve this include nanostructuring the material to scatter phonons more effectively than electrons (thereby reducing thermal conductivity more than electrical conductivity), and doping the material to optimize carrier concentration.

Q2: What is the importance of the figure of merit (ZT) and what are typical values for common materials?

A2: The ZT value is the primary indicator of a thermoelectric material's performance. A higher ZT leads to a higher potential energy conversion efficiency. The ZT of a material is temperature-dependent. Below is a table summarizing typical ZT values for common thermoelectric materials at different temperatures.

Material Family	Common Compositions	Peak ZT (approx.)	Optimal Temperature Range (°C)
Bismuth Telluride	$\text{Bi}_2\text{Te}_3$ , $(\text{Bi,Sb})_2\text{Te}_3$	~1.0 - 1.4	25 - 200
Lead Telluride	$\text{PbTe}$	~1.5 - 2.2	300 - 600
Skutterudites	$\text{CoSb}_3$ -based	~1.0 - 1.8	400 - 700
Silicon-Germanium	$\text{SiGe}$	~1.0	600 - 1000

Note: These are representative values. Actual ZT can vary significantly with material synthesis, processing, and doping.

Q3: How does the geometry of the thermoelectric elements affect the generator's performance?

A3: The geometry of the p-n legs in a TEG module is crucial for optimizing performance under specific thermal and electrical conditions.

- **Length of the Elements:** Longer elements can support a larger temperature difference but also have higher electrical and thermal resistance. Shorter elements have lower resistance but may be less effective at maintaining a large  $\Delta T$ .
- **Cross-Sectional Area:** A larger cross-sectional area reduces electrical and thermal resistance, allowing for higher current and heat flow. The optimal geometry depends on the properties of the thermoelectric material and the external thermal and electrical resistances. Multi-objective genetic algorithms and other computational methods have been used to optimize leg geometry, with studies showing that such optimization can increase power output by over 50%.

Q4: Can I connect multiple TEG modules together to increase the power output?

A4: Yes, TEG modules can be connected in series, parallel, or a combination of both to achieve the desired voltage and current output.

- **Series Connection:** Increases the output voltage while the current remains the same as that of a single module.
- **Parallel Connection:** Increases the output current while the voltage remains the same as that of a single module.

It is important to note that the maximum output power is not affected by the connection pattern, but the output voltage and current are. When connecting modules, ensure they have similar characteristics and are subjected to similar temperature gradients to avoid performance degradation.

## Experimental Protocols

### Protocol 1: Measurement of Seebeck Coefficient and Electrical Resistivity

This protocol describes a standard method for characterizing the fundamental properties of a thermoelectric material.

**Objective:** To determine the Seebeck coefficient ( $S$ ) and electrical resistivity ( $\rho$ ) of a bulk thermoelectric sample as a function of temperature.

#### Apparatus:

- Sample holder with two heater blocks and electrical contacts.
- Two T-type thermocouples.
- DC power supply.
- Voltmeter and Ammeter (or a source measure unit).
- Vacuum chamber or inert gas environment to prevent oxidation at high temperatures.

#### Procedure:

- **Sample Preparation:** Cut the thermoelectric material into a rectangular bar of known dimensions.

- Mounting the Sample: Mount the sample between the two heater blocks in the sample holder. Ensure good thermal and electrical contact.
- Thermocouple Placement: Attach the two thermocouples at two distinct points along the length of the sample. The thermocouple wires will be used to measure both the temperature and the voltage difference.
- Establishing a Temperature Gradient:
  - Heat the entire sample holder to the desired base temperature.
  - Activate the small heater on one of the blocks to create a small temperature gradient (typically a few Kelvin) along the sample.
- Seebeck Coefficient Measurement:
  - Record the temperatures ( $T_1$  and  $T_2$ ) at the two thermocouple locations.
  - Measure the voltage difference ( $\Delta V$ ) between the two positive leads of the thermocouples.
  - The Seebeck coefficient is calculated as  $S = -\Delta V / (T_1 - T_2)$ .
- Electrical Resistivity Measurement (Four-Probe Method):
  - Pass a known DC current ( $I$ ) through the length of the sample using the outer contacts.
  - Measure the voltage drop ( $V$ ) across the two inner thermocouple contacts.
  - The resistance ( $R$ ) is calculated using Ohm's law:  $R = V / I$ .
  - The electrical resistivity ( $\rho$ ) is then calculated as  $\rho = R * (A / L)$ , where  $A$  is the cross-sectional area of the sample and  $L$  is the distance between the inner voltage probes.
- Data Collection: Repeat steps 4-6 for a range of desired temperatures.

## Protocol 2: Characterization of TEG Module Efficiency

Objective: To determine the power output and conversion efficiency of a complete TEG module.

#### Apparatus:

- Controlled heat source (e.g., electric heater, hot plate).
- Heat sink (air-cooled or water-cooled).
- Two thermocouples.
- Variable electronic load.
- Voltmeter and Ammeter.
- Heat flux sensor (optional, for direct efficiency measurement).

#### Procedure:

- TEG Setup:
  - Apply a thin layer of thermal grease to both sides of the TEG module.
  - Place the TEG between the heat source and the heat sink.
  - Apply a uniform and measurable clamping pressure.
  - Attach one thermocouple to the hot side and one to the cold side of the TEG.
- Open-Circuit Voltage ( $V_{oc}$ ) Measurement:
  - Set the heat source to a desired temperature and allow the system to reach thermal equilibrium.
  - Record the hot-side ( $T_h$ ) and cold-side ( $T_c$ ) temperatures.
  - With the electronic load disconnected, measure the voltage across the TEG terminals. This is the open-circuit voltage.
- Power Output Measurement:
  - Connect the variable electronic load to the TEG.

- Vary the load resistance ( $R_L$ ) in steps.
- At each resistance step, allow the system to stabilize and record the voltage ( $V$ ) across the load and the current ( $I$ ) flowing through it.
- Calculate the power output ( $P$ ) at each step using  $P = V * I$ .
- Finding Maximum Power Point:
  - Plot the power output as a function of the load resistance.
  - The peak of this curve represents the maximum power output ( $P_{max}$ ) for that temperature difference, which occurs when the load resistance matches the internal resistance of the TEG.
- Efficiency Calculation:
  - Method 1 (with Heat Flux Sensor): Place a heat flux sensor between the heat source and the TEG. The efficiency ( $\eta$ ) is calculated as  $\eta = P_{max} / Q_{in}$ , where  $Q_{in}$  is the heat flux measured by the sensor.
  - Method 2 (without Heat Flux Sensor): The heat input can be estimated by measuring the temperature difference across a material of known thermal conductance placed in series with the TEG. This method is more complex and prone to errors.
- Data Analysis: Repeat the experiment for different hot-side temperatures to generate a performance map of the TEG module.

## Visualizations

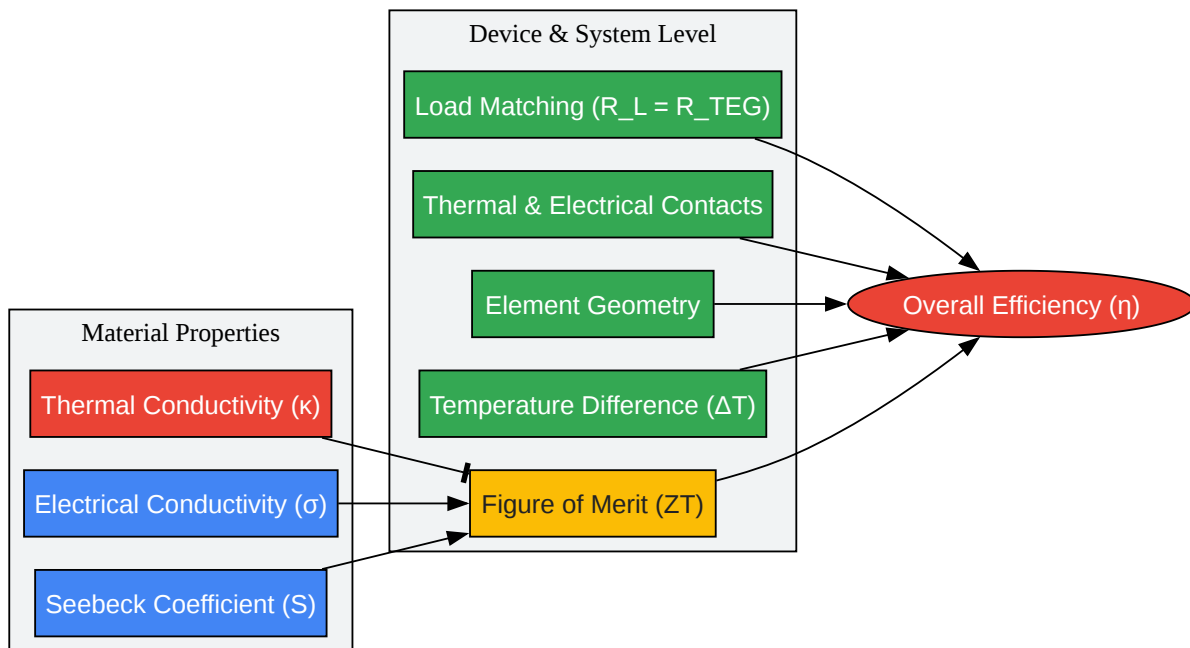

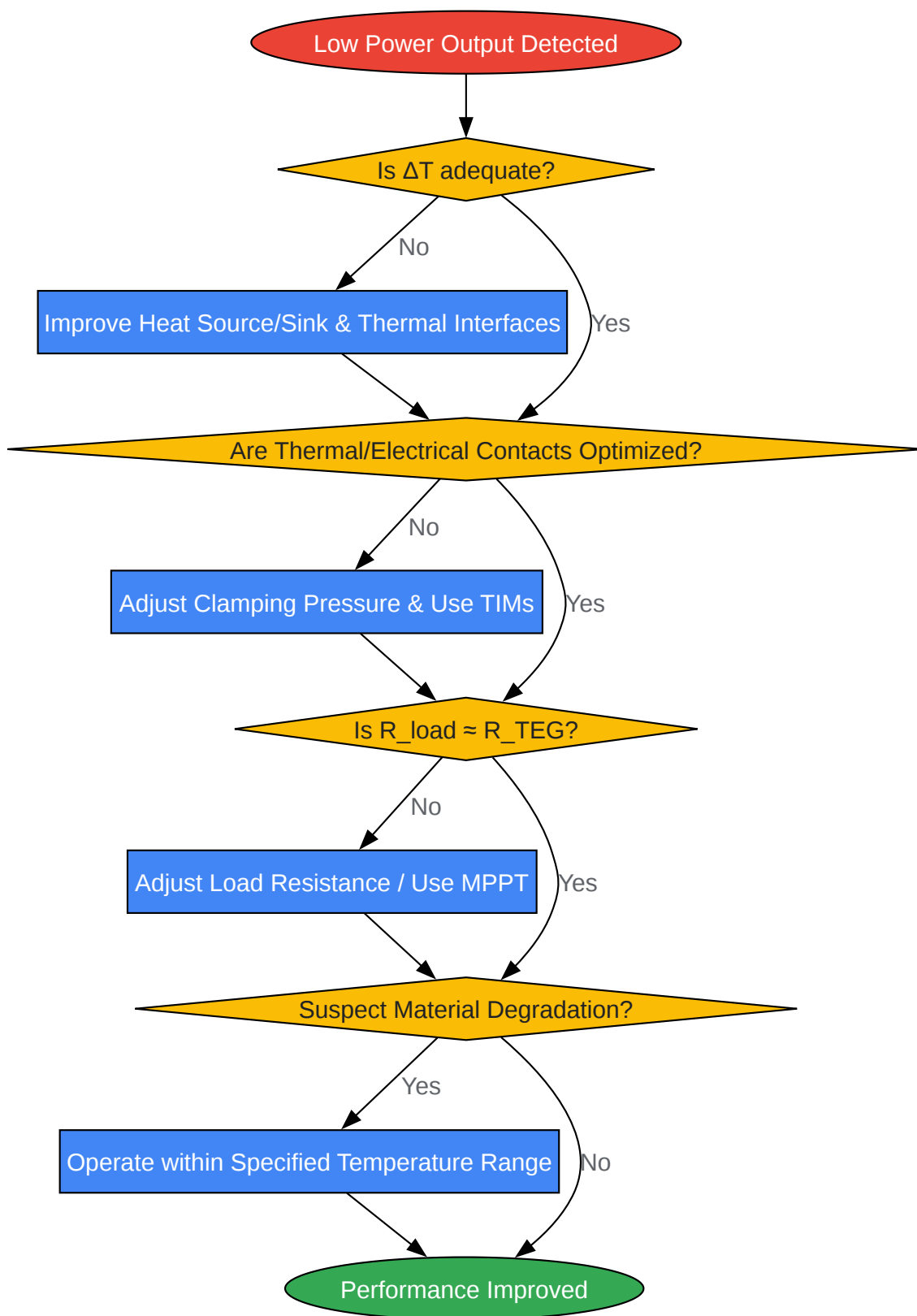

[Click to download full resolution via product page](#)

### Need Custom Synthesis?

BenchChem offers custom synthesis for rare earth carbides and specific isotopic labeling.

Email: [info@benchchem.com](mailto:info@benchchem.com) or [Request Quote Online](#).

## References

- [1. researchgate.net \[researchgate.net\]](https://www.researchgate.net)
- [2. pubs.aip.org \[pubs.aip.org\]](https://pubs.aip.org)
- [3. nplindia.in \[nplindia.in\]](https://nplindia.in)
- [4. Thermoelectrics \[thermoelectrics.matsci.northwestern.edu\]](https://thermoelectrics.matsci.northwestern.edu)
- To cite this document: BenchChem. [Technical Support Center: Enhancing Thermoelectric Generator (TEG) Efficiency]. BenchChem, [2026]. [Online PDF]. Available at: [\[https://www.benchchem.com/product/b12388539/docs#technical-support-center-enhancing-thermoelectric-generator-teg-efficiency\]](https://www.benchchem.com/product/b12388539/docs#technical-support-center-enhancing-thermoelectric-generator-teg-efficiency)

---

### Disclaimer & Data Validity:

The information provided in this document is for Research Use Only (RUO) and is strictly not intended for diagnostic or therapeutic procedures. While BenchChem strives to provide accurate protocols, we make no warranties, express or implied, regarding the fitness of this product for every specific experimental setup.

**Technical Support:** The protocols provided are for reference purposes. Unsure if this reagent suits your experiment?

**Need Industrial/Bulk Grade?** [Request Custom Synthesis Quote](#)

# BenchChem

Our mission is to be the trusted global source of essential and advanced chemicals, empowering scientists and researchers to drive progress in science and industry.

## Contact

Address: 3281 E Guasti Rd

Ontario, CA 91761, United States

Phone: (601) 213-4426

Email: [info@benchchem.com](mailto:info@benchchem.com)

[Contact our Ph.D. Support Team for a compatibility check](#)