

Navigating the Landscape of Thermoelectric Generation: A Cost-Performance Comparison

Author: BenchChem Technical Support Team. **Date:** April 2026

Compound of Interest

Compound Name: G43-C3-TEG

Cat. No.: B12388539

[Get Quote](#)

For researchers, scientists, and drug development professionals seeking to harness waste heat or develop novel power sources, Thermoelectric Generators (TEGs) offer a solid-state solution for direct energy conversion. This guide provides a comparative analysis of various TEG technologies, focusing on their cost-performance ratio, supported by experimental data and detailed methodologies.

Thermoelectric generators operate on the Seebeck effect, where a temperature difference across a semiconductor material generates an electric voltage. The efficiency of this conversion is primarily determined by the material's dimensionless figure of merit (ZT), which is a function of the Seebeck coefficient (S), electrical conductivity (σ), and thermal conductivity (κ) at a specific absolute temperature (T): $ZT = S^2\sigma T/\kappa$. [1][2] A higher ZT value indicates a more efficient thermoelectric material. However, the practical application and commercial viability of TEG technologies hinge not only on their efficiency but also on their cost per watt of power generated.

Comparative Analysis of TEG Technologies

The selection of a TEG technology is often a trade-off between performance and cost, largely dictated by the operating temperature of the heat source. Different materials exhibit optimal ZT

values at different temperature ranges. The following table summarizes the key performance and cost metrics for prominent TEG materials and commercially available modules.

TEG Technology/Material	Optimal Operating Temperature (°C)	Peak ZT Value (approx.)	Module Power Output (W)	Module Cost (USD)	System Cost (\$/W)	Key Applications
Bismuth Telluride (Bi_2Te_3) & Alloys	25 - 250	1.0 - 1.4 ^[3] [4]	1 - 22 ^[5]	\$12 - \$57	>10 (system)	Low-grade waste heat recovery, cooling, wearable devices.
Lead Telluride (PbTe) & Alloys	300 - 600	~1.5 - 2.0	Custom modules	Higher than Bi_2Te_3	<1 (material, at >275°C)	Mid-to-high temperature waste heat recovery (e.g., automotive exhaust).
Skutterudites (e.g., CoSb_3 -based)	400 - 700	~1.2 - 1.8	Custom modules	High	<1 (material, at >275°C)	High-temperature industrial waste heat, deep space missions (in RTGs).
Half-Heusler Alloys	500 - 800	~1.0 - 1.5	Custom modules	High	<1 (material, at >275°C)	Automotive and industrial waste heat recovery.

Commercial TEG Modules (General)	Varies	Varies	1 - 100+	\$12 - \$718+	\$4 - \$14+ (system)	Wood stoves, off- grid power, industrial sensors.
---	--------	--------	----------	------------------	-------------------------	---

Note: Module costs are based on retail prices for individual units and can vary significantly with volume and supplier. System costs are estimates and are heavily influenced by the cost of heat exchangers and other balance-of-system components, which can dominate the overall price.

The Seebeck Effect: The Engine of Thermoelectric Generation

The fundamental principle underlying all TEG technologies is the Seebeck effect. When a temperature gradient is applied across a thermoelectric material, charge carriers (electrons or holes) diffuse from the hot side to the cold side, creating a net charge buildup and, consequently, an electric potential.

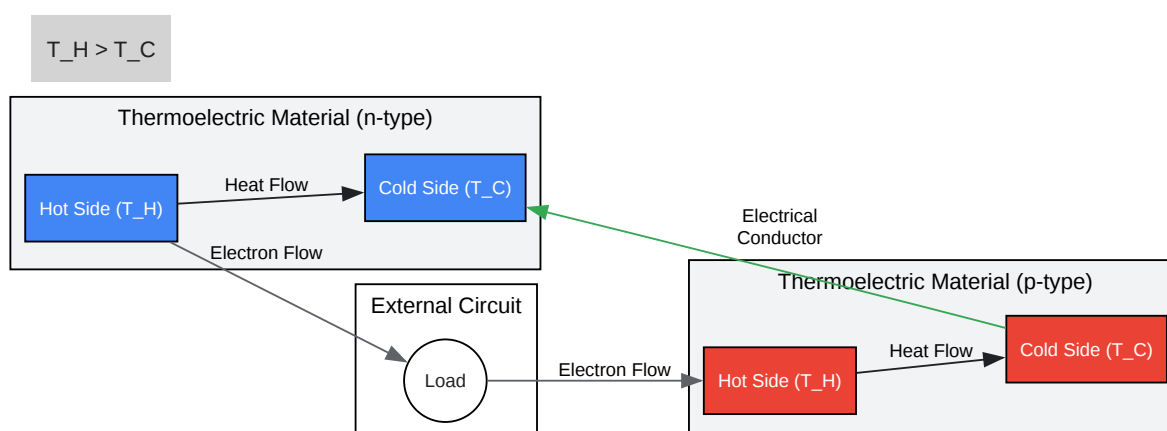

[Click to download full resolution via product page](#)

The Seebeck Effect in a TEG Module.

Experimental Protocols for TEG Performance Characterization

Objective and accurate characterization of TEG performance is crucial for research and development. Below is a generalized protocol for evaluating the key performance metrics of a TEG module.

Objective: To measure the power output and efficiency of a TEG module under varying temperature gradients and load resistances.

Materials and Equipment:

- TEG module to be tested
- Controlled heat source (e.g., electric hot plate, cartridge heater)
- Heat sink (air-cooled or water-cooled) for the cold side
- K-type thermocouples for temperature measurement
- Data acquisition system (for logging temperature, voltage, and current)
- Variable electronic load
- Thermal paste or graphite sheets for ensuring good thermal contact
- Insulating material to minimize heat loss

Procedure:

- **Module Preparation:** Apply a thin, uniform layer of thermal paste or place graphite sheets on both the hot and cold sides of the TEG module.
- **Experimental Setup Assembly:**
 - Place the TEG module on the heat source.
 - Mount the heat sink on the cold side of the TEG module.

- Attach thermocouples to the surfaces of the hot and cold sides of the TEG, ensuring they are as close to the module's ceramic plates as possible.
- Connect the TEG's output leads to the variable electronic load and the data acquisition system for voltage and current measurement.
- Connect the thermocouples to the data acquisition system.
- Insulate the setup to minimize convective heat losses to the surroundings.
- Data Acquisition:
 - Set the heat source to a specific temperature and allow the system to reach thermal equilibrium (i.e., when temperature readings are stable).
 - Vary the electronic load resistance across a wide range, from a short circuit to an open circuit.
 - At each resistance value, record the steady-state hot-side temperature (T_H), cold-side temperature (T_C), output voltage (V), and output current (I).
- Calculations:
 - Power Output (P): $P = V * I$. The maximum power output (P_{max}) occurs when the load resistance matches the internal resistance of the TEG module.
 - Efficiency (η): $\eta = P / Q_H$, where Q_H is the heat absorbed at the hot side. Accurately measuring Q_H is challenging and often requires more complex setups like a guarded hot plate or a heat flux sensor.

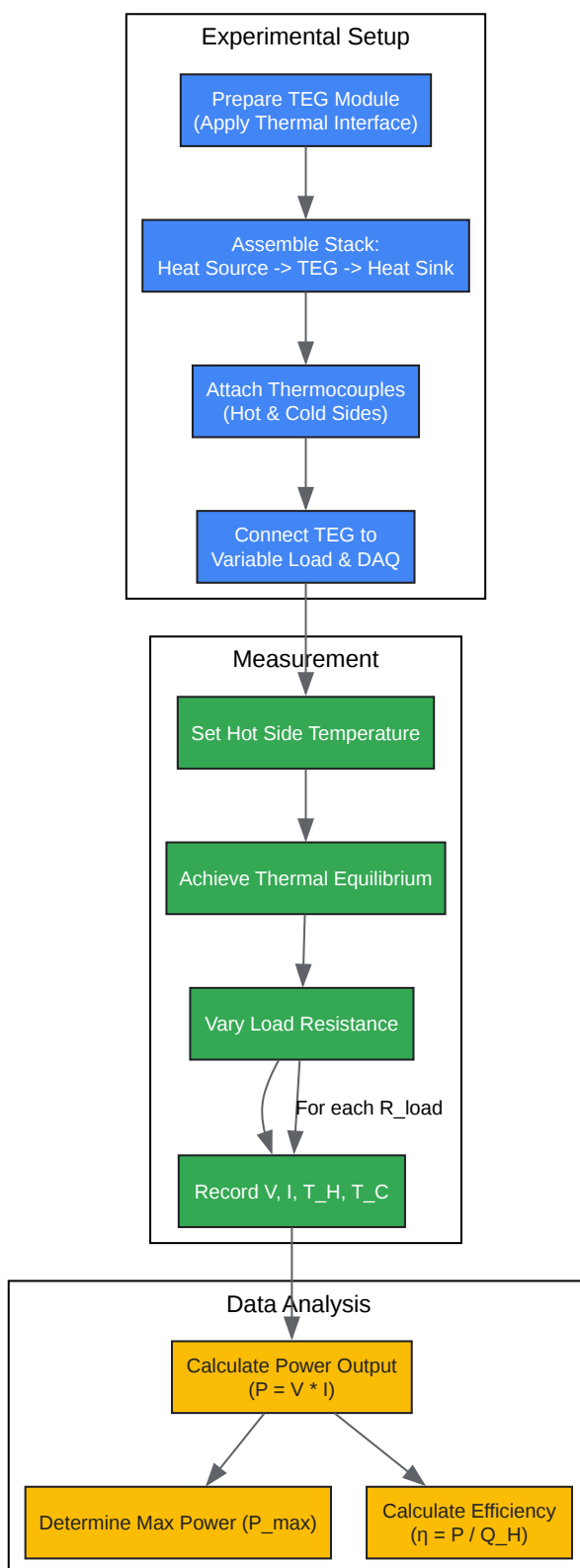

[Click to download full resolution via product page](#)

Workflow for TEG Performance Characterization.

Factors Influencing the Cost-Performance Ratio

The cost-performance ratio of a TEG system is not solely dependent on the thermoelectric material itself. A holistic view reveals a complex interplay of material properties, manufacturing processes, and system-level components.

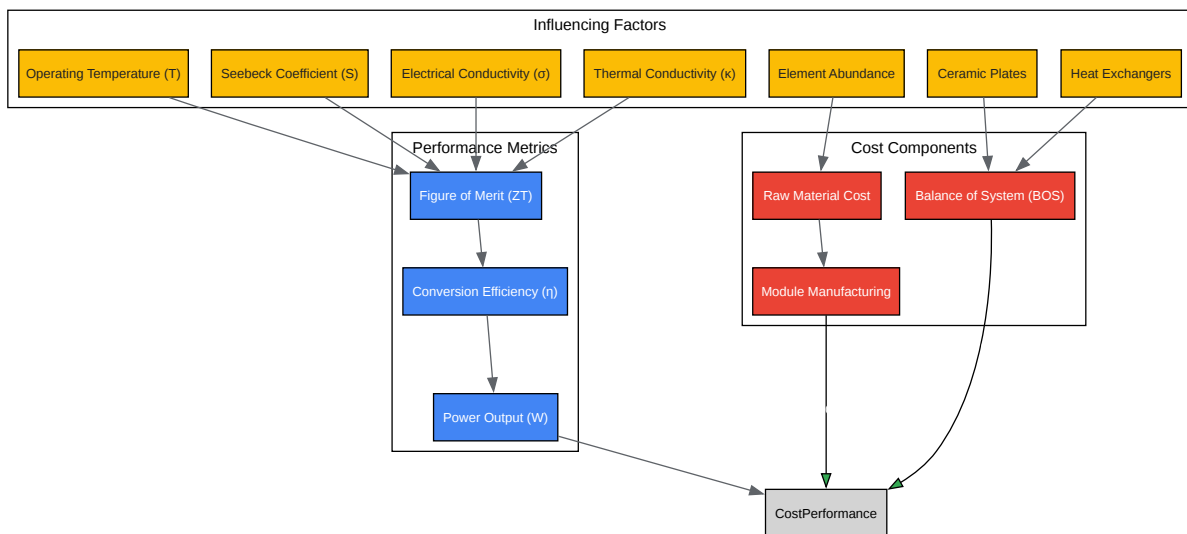

[Click to download full resolution via product page](#)

Key Factors Determining TEG Cost-Performance.

As the diagrams and data illustrate, while high-ZT materials are crucial for achieving high efficiency, the overall system cost, particularly for heat exchangers, can be a major barrier to widespread adoption. Future advancements in both materials science and system integration

will be critical in improving the cost-performance ratio of TEG technologies, unlocking their potential in a wider range of applications.

Need Custom Synthesis?

BenchChem offers custom synthesis for rare earth carbides and specific isotopic labeling.

Email: info@benchchem.com or [Request Quote Online](#).

References

- [1. TEGmart - Thermoelectric Generator Products \[tegmart.com\]](#)
- [2. web.mit.edu \[web.mit.edu\]](#)
- [3. Bismuth Telluride and Its Alloys as Materials for Thermoelectric Generation - PMC \[pmc.ncbi.nlm.nih.gov\]](#)
- [4. Thermoelectric Modules - TEGmart \[tegmart.com\]](#)
- [5. leblanclab.com \[leblanclab.com\]](#)
- To cite this document: BenchChem. [Navigating the Landscape of Thermoelectric Generation: A Cost-Performance Comparison]. BenchChem, [2026]. [Online PDF]. Available at: [<https://www.benchchem.com/product/b12388539/docs#navigating-the-landscape-of-thermoelectric-generation-a-cost-performance-comparison>]

Disclaimer & Data Validity:

The information provided in this document is for Research Use Only (RUO) and is strictly not intended for diagnostic or therapeutic procedures. While BenchChem strives to provide accurate protocols, we make no warranties, express or implied, regarding the fitness of this product for every specific experimental setup.

Technical Support: The protocols provided are for reference purposes. Unsure if this reagent suits your experiment?

Need Industrial/Bulk Grade? [Request Custom Synthesis Quote](#)

BenchChem

Our mission is to be the trusted global source of essential and advanced chemicals, empowering scientists and researchers to drive progress in science and industry.

Contact

Address: 3281 E Guasti Rd

Ontario, CA 91761, United States

Phone: (601) 213-4426

Email: info@benchchem.com

[Contact our Ph.D. Support Team for a compatibility check](#)