

Methodology for Assessing MSN8C Efficacy In Vivo: Application Notes and Protocols

Author: BenchChem Technical Support Team. **Date:** April 2026

Compound of Interest

Compound Name: MSN8C
Cat. No.: B12388120

[Get Quote](#)

For Researchers, Scientists, and Drug Development Professionals

Introduction

MSN8C, an analog of mansonone E, has emerged as a promising novel catalytic inhibitor of human DNA topoisomerase II (Topo II).[1][2][3] Unlike Topo II poisons such as etoposide, which stabilize the enzyme-DNA cleavage complex, **MSN8C** inhibits the catalytic activity of Topo II, potentially by competing with ATP for its binding site on the enzyme.[1] This mechanism of action prevents the re-ligation of DNA double-strand breaks, ultimately leading to tumor cell apoptosis and regression.[2] **MSN8C** has demonstrated significant antiproliferative activity against a range of human tumor cell lines in vitro and has shown potent antitumor efficacy in vivo, particularly in models resistant to conventional Topo II poisons.[1][2][3]

These application notes provide detailed protocols for assessing the in vivo efficacy of **MSN8C** using a human tumor xenograft model in immunodeficient mice. The described methodologies cover animal model selection, tumor cell implantation, treatment administration, and endpoint analysis, offering a comprehensive guide for preclinical evaluation of **MSN8C** and similar Topo II catalytic inhibitors.

Data Presentation

Table 1: In Vivo Efficacy of **MSN8C** in A549 Human Lung Carcinoma Xenograft Model

Treatment Group	Dose	Administration Route	Schedule	Tumor Weight Inhibition (TWI) (%)
Vehicle Control	-	Intraperitoneal (i.p.)	Every two days for 2 weeks	0
MSN8C	10 mg/kg	Intraperitoneal (i.p.)	Every two days for 2 weeks	74.2
Adriamycin (ADR)	2.5 mg/kg	Intraperitoneal (i.p.)	Every two days for 2 weeks	76.5

Data summarized from in vivo studies demonstrating the anti-tumor effects of **MSN8C**.

Experimental Protocols

Human Tumor Xenograft Model Establishment

This protocol outlines the procedure for establishing a subcutaneous human tumor xenograft model in nude mice, a commonly used model for evaluating the efficacy of anti-cancer agents. [\[4\]](#)[\[5\]](#)

Materials:

- Human cancer cell line (e.g., A549 human lung carcinoma)
- Female athymic nude mice (BALB/c-nu/nu), 5-6 weeks old
- Complete cell culture medium (e.g., RPMI-1640 with 10% FBS)
- Phosphate-buffered saline (PBS), sterile
- Trypsin-EDTA

- Hemocytometer or automated cell counter
- 1 ml syringes with 27-gauge needles
- Laminar flow hood
- Animal housing facility with appropriate caging and environmental controls

Procedure:

- Cell Culture: Culture A549 cells in RPMI-1640 medium supplemented with 10% fetal bovine serum and 1% penicillin-streptomycin at 37°C in a humidified atmosphere of 5% CO₂.
- Cell Harvesting: When cells reach 80-90% confluency, wash them with PBS and detach using trypsin-EDTA. Neutralize the trypsin with complete medium and centrifuge the cell suspension at 1,000 rpm for 5 minutes.
- Cell Viability and Counting: Resuspend the cell pellet in serum-free medium or PBS. Determine cell viability and count using a hemocytometer and trypan blue exclusion or an automated cell counter.
- Cell Suspension Preparation: Adjust the cell concentration to 1×10^7 viable cells per 0.1 ml in serum-free medium or PBS. Keep the cell suspension on ice to maintain viability.
- Tumor Cell Implantation:
 - Anesthetize the mice using an appropriate method (e.g., isoflurane inhalation).
 - Disinfect the injection site on the right flank of the mouse with 70% ethanol.
 - Subcutaneously inject 0.1 ml of the cell suspension (1×10^7 cells) into the right flank of each mouse using a 1 ml syringe with a 27-gauge needle.
- Tumor Growth Monitoring:
 - Monitor the animals twice weekly for tumor appearance.

- Once tumors are palpable, measure the tumor dimensions (length and width) using digital calipers every two to three days.[6]
- Calculate the tumor volume using the formula: Tumor Volume (mm³) = (length x width²) / 2. [6][7]
- Animals are typically ready for treatment when the tumor volume reaches approximately 100-150 mm³.

Intraperitoneal (i.p.) Administration of MSN8C

This protocol details the procedure for intraperitoneal injection of **MSN8C** in mice.

Materials:

- **MSN8C** compound
- Vehicle solution (e.g., sterile saline with 5% DMSO and 5% Tween 80)
- Adriamycin (ADR) as a positive control
- 1 ml syringes with 27-gauge needles
- Animal scale

Procedure:

- Drug Preparation:
 - Prepare a stock solution of **MSN8C** in a suitable solvent (e.g., DMSO).
 - On the day of injection, dilute the **MSN8C** stock solution with sterile saline to the final desired concentration for a 10 mg/kg dose. The final injection volume should be approximately 0.1 ml per 20g mouse.
 - Prepare the Adriamycin (ADR) solution in sterile saline for a 2.5 mg/kg dose.
 - Prepare the vehicle control solution.

- Animal Restraint:
 - Weigh each mouse to accurately calculate the injection volume.
 - Restrain the mouse by grasping the loose skin over the neck and back, ensuring the animal is secure but can breathe comfortably.
 - Tilt the mouse to a slight head-down position to allow the abdominal organs to shift cranially.
- Injection:
 - Locate the injection site in the lower right quadrant of the abdomen to avoid the cecum and bladder.[8]
 - Insert a 27-gauge needle at a 30-45 degree angle into the peritoneal cavity.[9][10]
 - Gently aspirate to ensure the needle has not entered a blood vessel or organ.[9]
 - Slowly inject the calculated volume of the **MSN8C** solution, control drug, or vehicle.
 - Withdraw the needle and return the mouse to its cage.
- Treatment Schedule: Administer the treatments intraperitoneally every two days for a total of two weeks.

Efficacy Evaluation and Endpoint Analysis

This protocol describes the procedures for monitoring treatment efficacy and collecting samples at the end of the study.

Materials:

- Digital calipers
- Animal scale
- Euthanasia equipment (e.g., CO2 chamber, isoflurane)

- Surgical instruments for tissue collection
- 10% neutral buffered formalin
- Cryovials for snap-freezing tissues

Procedure:

- Monitoring:
 - Measure tumor volume and body weight every two to three days throughout the treatment period.[\[6\]](#)
 - Monitor the animals for any signs of toxicity, such as weight loss, lethargy, or ruffled fur.
- Humane Endpoints: Euthanize animals if the tumor volume exceeds 2000 mm³, the tumor becomes ulcerated, or the animal shows signs of significant distress or more than 20% weight loss.[\[6\]](#)[\[7\]](#)
- Study Termination and Sample Collection:
 - At the end of the two-week treatment period (or when humane endpoints are reached), euthanize the mice using an approved method (e.g., CO₂ asphyxiation followed by cervical dislocation).[\[11\]](#)[\[12\]](#)
 - Immediately following euthanasia, dissect the tumors and weigh them.
 - Calculate the Tumor Weight Inhibition (TWI) using the formula: $TWI (\%) = [1 - (\text{Average tumor weight of treated group} / \text{Average tumor weight of control group})] \times 100$.
 - Collect tumors and other organs of interest (e.g., liver, kidneys, heart) for further analysis.
 - For histological analysis, fix a portion of the tumor and organs in 10% neutral buffered formalin.
 - For molecular analysis (e.g., Western blot, PCR), snap-freeze a portion of the tumor and organs in liquid nitrogen and store at -80°C.

Visualizations

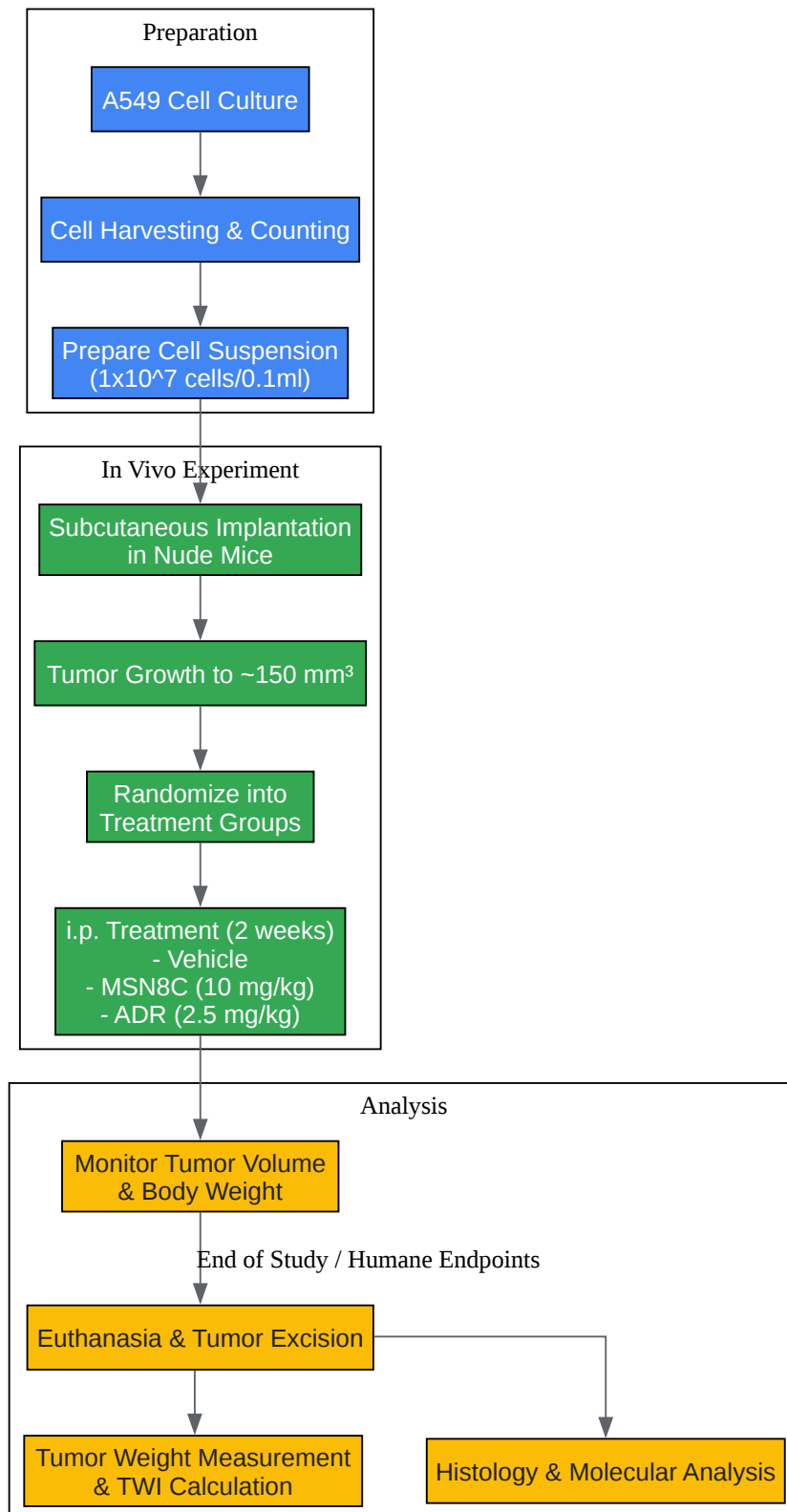

[Click to download full resolution via product page](#)

Caption: Experimental workflow for assessing **MSN8C** in vivo efficacy.

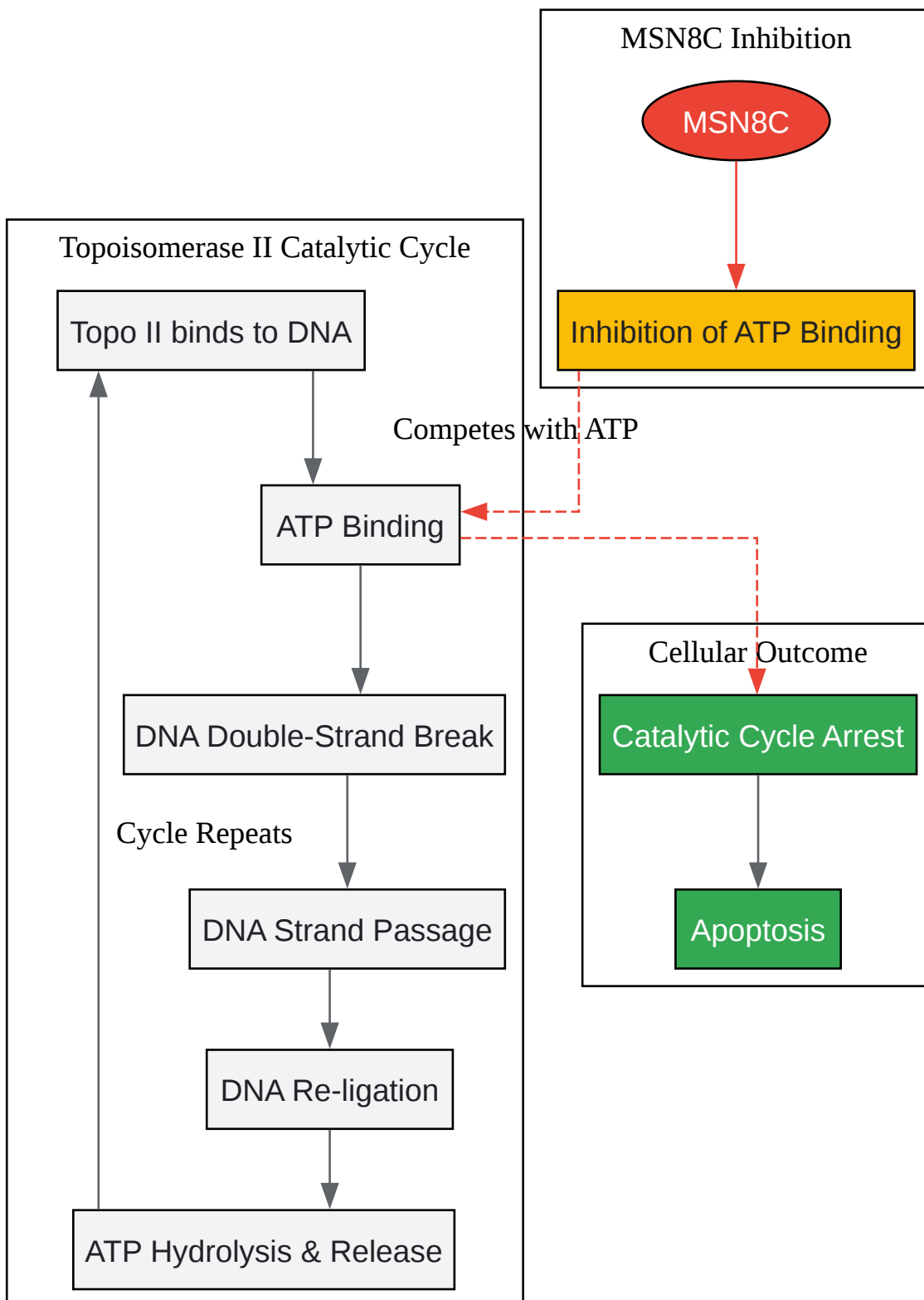

[Click to download full resolution via product page](#)

Caption: Proposed mechanism of **MSN8C** action on the Topoisomerase II signaling pathway.

Need Custom Synthesis?

BenchChem offers custom synthesis for rare earth carbides and specific isotopic labeling.

Email: info@benchchem.com or [Request Quote Online](#).

References

- 1. MSN8C: A Promising Candidate for Antitumor Applications as a Novel Catalytic Inhibitor of Topoisomerase II - PMC [[pmc.ncbi.nlm.nih.gov](https://pubmed.ncbi.nlm.nih.gov/)]
- 2. cancer-research-network.com [cancer-research-network.com]
- 3. MSN8C: A Promising Candidate for Antitumor Applications as a Novel Catalytic Inhibitor of Topoisomerase II - PubMed [pubmed.ncbi.nlm.nih.gov]
- 4. Challenges in pre-clinical testing of anti-cancer drugs in cell culture and in animal models - PMC [[pmc.ncbi.nlm.nih.gov](https://pubmed.ncbi.nlm.nih.gov/)]
- 5. Tumorigenicity Assay in Nude Mice - PMC [[pmc.ncbi.nlm.nih.gov](https://pubmed.ncbi.nlm.nih.gov/)]
- 6. iacuc.wsu.edu [iacuc.wsu.edu]
- 7. Article - Standard on Tumor Productio... [policies.unc.edu]
- 8. Intraperitoneal Injection in Mice | Animals in Science [queensu.ca]
- 9. ltk.uzh.ch [ltk.uzh.ch]
- 10. uac.arizona.edu [uac.arizona.edu]
- 11. 300 Multiple Choices [umaryland.edu]
- 12. research.unc.edu [research.unc.edu]
- To cite this document: BenchChem. [Methodology for Assessing MSN8C Efficacy In Vivo: Application Notes and Protocols]. BenchChem, [2026]. [Online PDF]. Available at: [<https://www.benchchem.com/product/b12388120/docs#methodology-for-assessing-msn8c-efficacy-in-vivo-application-notes-and-protocols>]

Disclaimer & Data Validity:

The information provided in this document is for Research Use Only (RUO) and is strictly not intended for diagnostic or therapeutic procedures. While BenchChem strives to provide accurate protocols, we make no warranties, express or implied, regarding the fitness of this product for every specific experimental setup.

Technical Support: The protocols provided are for reference purposes. Unsure if this reagent suits your experiment?

Need Industrial/Bulk Grade? [Request Custom Synthesis Quote](#)

BenchChem

Our mission is to be the trusted global source of essential and advanced chemicals, empowering scientists and researchers to drive progress in science and industry.

Contact

Address: 3281 E Guasti Rd
Ontario, CA 91761, United States
Phone: (601) 213-4426
Email: info@benchchem.com

[Contact our Ph.D. Support Team for a compatibility check](#)