

In Vitro Anti-Cancer Profiling of Ganoderic

Author: BenchChem Technica

Compound of Interest

Compound Name: *Lanosta-7,9(11),23,25(27)-tetraen-26-oic acid, 23,27-epoxy-3-oxo-*

Cat. No.: B12388074

[Get Quote](#)

Introduction: The Therapeutic Potential of Ganoderic Acid Y in Oncology

Ganoderic acids, a class of highly oxygenated lanostane-type triterpenoids derived from the medicinal mushroom *Ganoderma lucidum*, have garnered as a promising candidate for anti-cancer drug development. Numerous studies have indicated that ganoderic acids can exert potent anti-tumor and ar (programmed cell death), arrest of the cell cycle at critical checkpoints, and modulation of key signaling pathways that govern cell proliferation and su

This comprehensive application note provides a detailed, step-by-step guide for researchers, scientists, and drug development professionals to rigor integrity and reproducibility. We will delve into the causality behind experimental choices, offering insights honed from extensive experience in the field invasive potential.

Experimental Design & Workflow

A systematic approach is crucial for elucidating the anti-cancer profile of a novel compound. The following workflow provides a logical progression fro

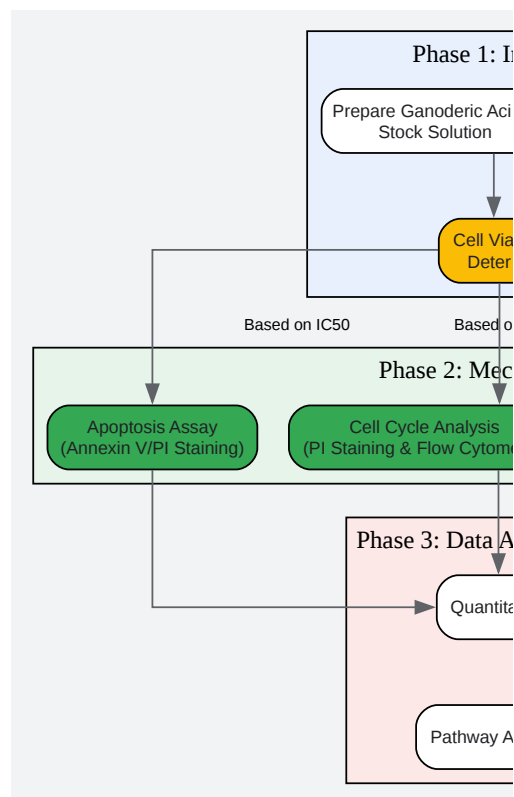

[Click to download full re](#)

Caption: Experimental workflow for in vitro anti-cancer evaluation of Ganoderic acid Y.

PART I: Foundational Protocols & Methodologies

Preparation of Ganoderic Acid Y Stock Solution

The solubility of the test compound is a critical first step. Ganoderic acids generally exhibit poor aqueous solubility.[5][6] Therefore, a suitable organic

- Recommended Solvent: Anhydrous Dimethyl Sulfoxide (DMSO).[7][8]
- Protocol:
 - Prepare a high-concentration stock solution (e.g., 50-100 mM) of Ganoderic acid Y in sterile, anhydrous DMSO.
 - Gently warm and vortex or sonicate to ensure complete dissolution.[9]
 - Aliquot the stock solution into smaller volumes to avoid repeated freeze-thaw cycles.
 - Store at -20°C or -80°C for long-term stability.
- Causality & Expertise: Using anhydrous DMSO is crucial as moisture can reduce the solubility of many compounds.[7] Aliquoting prevents degradation should not exceed 0.1% (v/v) to avoid solvent-induced cytotoxicity.

Cell Culture

The choice of cancer cell line(s) will depend on the research focus. It is advisable to use well-characterized cell lines from a reputable source like ATCC

- General Protocol:
 - Culture cells in the recommended medium supplemented with 10% Fetal Bovine Serum (FBS) and 1% Penicillin-Streptomycin.
 - Maintain cells in a humidified incubator at 37°C with 5% CO₂.
 - Ensure cells are in the exponential growth phase and have high viability (>95%) before seeding for experiments.

PART II: Core Anti-Cancer Assays

Cell Viability and Cytotoxicity (MTT Assay)

The MTT assay is a widely used colorimetric method to assess cell metabolic activity, which serves as an indicator of cell viability, proliferation, and cell

- Principle: Metabolically active cells possess mitochondrial dehydrogenase enzymes that reduce the yellow tetrazolium salt, 3-(4,5-dimethylthiazol-2-yl)-2,5-diphenyltetrazolium bromide (MTT) to a purple formazan product of viable cells.[9]
- Detailed Protocol:
 - Cell Seeding: Seed cancer cells in a 96-well plate at an optimized density (e.g., 5,000-10,000 cells/well) in 100 µL of complete culture medium.[1]
 - Treatment: Prepare serial dilutions of Ganoderic acid Y in culture medium from the DMSO stock. The final DMSO concentration should be constant and triplicate.
 - Incubation: Incubate the plate for specified periods (e.g., 24, 48, or 72 hours).[15][16]
 - MTT Addition: Add 10-20 µL of MTT solution (5 mg/mL in PBS) to each well and incubate for 3-4 hours at 37°C.[13]
 - Solubilization: Carefully aspirate the medium and add 150 µL of DMSO to each well to dissolve the formazan crystals.[9][13]
 - Absorbance Measurement: Shake the plate on an orbital shaker for 15 minutes to ensure complete dissolution.[13] Measure the absorbance at 550 nm.
 - Data Analysis: Calculate the percentage of cell viability relative to the vehicle control. Plot a dose-response curve to determine the half-maximal inhibitory concentration (IC₅₀).

- Data Presentation: Cytotoxic Activity of Ganoderic Acid Y

Cell Line	Treatment Duration (hr)
MCF-7 (Breast)	24
48	55.7
72	38.1
A549 (Lung)	24
48	63.9
72	45.3
HepG2 (Liver)	24
48	51.2
72	35.8

Table 1: Hypothetical IC50 values for Ganoderic acid Y against various cancer cell lines.

Apoptosis Assay (Annexin V-FITC/Propidium Iodide Staining)

This flow cytometry-based assay is a standard method for detecting apoptosis.

- Principle: During early apoptosis, phosphatidylserine (PS) translocates from the inner to the outer leaflet of the plasma membrane.^[17] Annexin V, and Propidium Iodide (PI) is a fluorescent nucleic acid dye that cannot cross the membrane of live or early apoptotic cells, but it can stain the nucleus of apoptotic, and necrotic cells.^[19]
- Detailed Protocol:
 - Cell Seeding and Treatment: Seed cells in 6-well plates and treat with Ganoderic acid Y at concentrations around the determined IC50 value (e.g.
 - Cell Harvesting: Collect both adherent and floating cells. For adherent cells, use gentle trypsinization.^[19] Wash the cells with cold PBS.
 - Cell Staining: Resuspend approximately $1-5 \times 10^5$ cells in 1X Annexin V Binding Buffer.^{[17][19]} Add 5 μ L of Annexin V-FITC and 5 μ L of PI (50 μ g
 - Incubation: Incubate the cells for 15 minutes at room temperature in the dark.^[20]
 - Flow Cytometry Analysis: Add 400 μ L of 1X Binding Buffer to each tube and analyze the stained cells by flow cytometry within one hour.^{[18][20]}
- Data Presentation: Apoptosis Induction by Ganoderic Acid Y

Treatment	Live Cells (%)	Early Apoptotic (%)
Control	95.1 \pm 2.3	2.5 \pm 0.8
GA-Y (0.5x IC50)	75.4 \pm 3.1	12.8 \pm 1.5
GA-Y (1x IC50)	48.2 \pm 4.5	25.7 \pm 2.9
GA-Y (2x IC50)	22.6 \pm 3.8	38.9 \pm 3.5

Table 2: Hypothetical data showing the percentage of cells in different stages after treatment with Ganoderic acid Y.

Cell Cycle Analysis (Propidium Iodide Staining)

This assay determines the effect of a compound on the progression of cells through the different phases of the cell cycle.

- Principle: Propidium Iodide (PI) stoichiometrically binds to DNA. The fluorescence intensity of PI-stained cells is directly proportional to the DNA content.
- Detailed Protocol:
 - Cell Seeding and Treatment: Seed cells in 6-well plates and treat with Ganoderic acid Y as described for the apoptosis assay.
 - Cell Harvesting: Harvest the cells and wash with cold PBS.
 - Fixation: Resuspend the cell pellet in ice-cold 70% ethanol while gently vortexing to prevent clumping.[23] Fix the cells overnight or for at least 2 hours.
 - Staining: Centrifuge the fixed cells and wash with PBS to remove the ethanol. Resuspend the cell pellet in a PI staining solution containing RNase A.
 - Incubation: Incubate for 30 minutes at room temperature in the dark.
 - Flow Cytometry Analysis: Analyze the samples using a flow cytometer. The data is typically displayed as a histogram of DNA content.
- Data Presentation: Cell Cycle Distribution after Ganoderic Acid Y Treatment

Treatment	G0/G1 Phase (%)	S Phase (%)
Control	55.3 ± 2.8	28.1 ± 1.5
GA-Y (0.5x IC50)	68.9 ± 3.4	19.5 ± 1.2
GA-Y (1x IC50)	78.2 ± 4.1	12.3 ± 0.8
GA-Y (2x IC50)	85.1 ± 4.7	7.6 ± 0.5

Table 3: Hypothetical data indicating a G0/G1 phase arrest induced by Ganoderic acid Y.

Cell Migration and Invasion Assays

These assays are critical for evaluating the anti-metastatic potential of Ganoderic acid Y.[25]

This is a simple and cost-effective method to study collective cell migration.[26][27]

- Principle: A "wound" or gap is created in a confluent cell monolayer. The rate at which cells migrate to close this gap is monitored over time.[27]
- Detailed Protocol:
 - Cell Seeding: Seed cells in a 12- or 24-well plate and grow them to form a confluent monolayer.[26]
 - Scratching: Create a straight scratch in the monolayer using a sterile 200 µL pipette tip.[27]
 - Washing and Treatment: Gently wash the wells with medium to remove detached cells.[26] Add fresh medium containing sub-lethal concentrations of Ganoderic acid Y.
 - Imaging: Capture images of the scratch at 0 hours and at regular intervals (e.g., 12, 24, 48 hours) using a microscope.[27]
 - Analysis: Measure the width of the gap at different time points and calculate the percentage of wound closure. ImageJ is a commonly used software for this purpose.

This assay assesses the ability of cancer cells to invade through a simulated extracellular matrix (ECM).[28][29][30]

- Principle: The assay uses a two-chamber system (a Transwell insert) where the upper and lower chambers are separated by a porous membrane. The upper chamber contains cells in a medium with a chemoattractant (e.g., 10% FBS). Invasive cells will degrade the Matrigel and migrate through the pores towards the chemoattractant.
- Detailed Protocol:
 - Chamber Preparation: Coat the upper surface of the Transwell inserts (typically with 8 µm pores) with Matrigel and allow it to solidify.[32]
 - Cell Seeding: Resuspend cells in serum-free medium containing sub-lethal concentrations of Ganoderic acid Y and seed them into the upper chamber.

- Incubation: Add complete medium (with FBS) to the lower chamber and incubate for 24-48 hours.[32]
 - Cell Removal and Fixation: Remove the non-invading cells from the upper surface of the membrane with a cotton swab.[31][32] Fix the invading
 - Staining and Counting: Stain the fixed cells with Crystal Violet.[28] Count the number of stained cells in several microscopic fields to quantify inva
- Data Presentation: Inhibition of Migration and Invasion by Ganoderic Acid Y

Assay	Treatment
Wound Healing	Control
GA-Y (0.1x IC50)	65.2 ± 6.1
GA-Y (0.25x IC50)	38.7 ± 4.9
Transwell Invasion	Control
GA-Y (0.1x IC50)	55.4 ± 7.3
GA-Y (0.25x IC50)	29.8 ± 5.6

Table 4: Hypothetical data demonstrating the inhibitory effect of Ganoderic acid Y on cancer cell migration and invasion.

PART III: Mechanistic Insights and Pathway Analysis

Ganoderic acids have been reported to modulate several key signaling pathways involved in cancer progression, including the PI3K/Akt and MAPK p survival pathways.

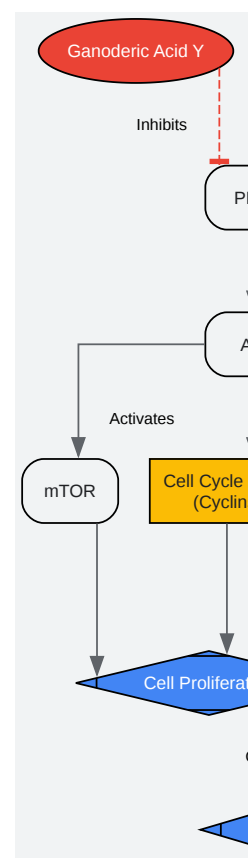

[Click to download full re](#)

Caption: Proposed signaling pathway for Ganoderic acid Y's anti-cancer effects.

Based on the hypothetical data, Ganoderic acid Y induces G0/G1 cell cycle arrest and promotes apoptosis. This aligns with findings for other ganode machinery. Furthermore, Akt is known to promote the G1/S transition, so its inhibition would logically lead to a G1 arrest. Further experiments, such as this proposed mechanism.

Conclusion

This application guide provides a robust framework for the comprehensive in vitro evaluation of Ganoderic acid Y's anti-cancer properties. By system: inhibitory effects, and anti-metastatic potential. The insights gained from these assays are crucial for advancing our understanding of Ganoderic acid

References

- Bhardwaj, A., et al. (2022). Anticancer drug screening of natural products: In vitro cytotoxicity assays, techniques, and challenges. *Journal of Applied* [redirect/AUZIYQGac_rzvpQZ9z_hlqCBFHGr2elbpt5cY5BUVURUn50pw2LcjqSj3wcWNxFOTEwMnfAIXNR7w5l243DXsgpAj9A6iC6zrBkHk_KHyByt](#)
- Abcam. (n.d.). Cell cycle analysis with flow cytometry and propidium iodide. Abcam. [https://vertexaisearch.cloud.google.com/grounding-api-redirect_OUOyV0-HtCNk3s0hfuuRZSJ1z23F0j97KDrMEf7eFYMoXL5NMBiVKnwh7n6XHq3D4Pg0NsKj_R6YLNmPf3axAdGD86AqgtBFxc3OyxayRPFd4N2LTcAp5fmLE_ZJymN0jzYa8LGi0kmYqLE__qKyBy-YeBA6LVGZruBnag_nLgtdZXqTizgf8dCnSGWSyV8UHVWQ==]
- Abcam. (n.d.). Annexin V staining assay protocol for apoptosis. Abcam. [https://vertexaisearch.cloud.google.com/grounding-api-redirect/AUZIYQGt4N2LTcAp5fmLE_ZJymN0jzYa8LGi0kmYqLE__qKyBy-YeBA6LVGZruBnag_nLgtdZXqTizgf8dCnSGWSyV8UHVWQ==]
- Liang, C. C., et al. (2007). Scratch Wound Healing Assay. *Bio-protocol*, 2(21), e279. [https://vertexaisearch.cloud.google.com/grounding-api-redirect_qVKhJPepzJToXHzhJZC8QEFe6mNyOHhXGyymN8fOJOadDY3VC135oBnc6Pgs3PuDp9gV_1234l8vrvDpbiojYmx1mgFabsZJ_cmRt]
- Sigma-Aldrich. (n.d.). The Endothelial Cell Transwell Migration and Invasion Assay. Sigma-Aldrich. [https://vertexaisearch.cloud.google.com/grounding-api-redirect/2T1k179r1A_kxYvtaA57UsHSoc81yLTtpveSW1DcRK_GZTI7ITJJ3Ttweti-pv7G_JEqcG44PgT4GKfzleV28NfkTf9UMJyEyGmSIKuT0b32K2g3axH]
- Jonkman, J. E., et al. (2014). How to do Wound Healing (Scratch) Assay for Cell Migration Analysis. *Journal of Visualized Experiments*, (84), e5120. [<https://doi.org/10.1002/1097-4644.ch44>]
- Creative Diagnostics. (n.d.). Annexin V-FITC Staining Protocol for Apoptosis Detection. Creative Diagnostics. [https://vertexaisearch.cloud.google.com/grounding-api-redirect/2lICYZJs4v7KEJoetBC9eYw6RrXmwSC3JnS1x4CNbH9hdKDZcBlSTMahEnMKHAsDvRtTvxiqiuGmQyWVt_YM7gSWUTaJx8oSHYReH331sBSvxl]
- BenchChem. (2025). Unraveling the Cytotoxic Landscape of Ganoderic Acids: A Comparative Guide. *BenchChem*. [https://vertexaisearch.cloud.google.com/grounding-api-redirect/AUZIYQEEGisp3zj8ParikyGh3v39tCL69fVA642xgYHn5pPi7UgjWELMrad1JZciNcjrvcUEcHqZ_TzjYPIZ096pIT3HGVSr1A8VMVDcyMEBGIICN]
- Corning. (n.d.). Transwell Cell Migration and Invasion Assay Guide. Corning. [https://vertexaisearch.cloud.google.com/grounding-api-redirect/AUZIYQdyPwePGcF1RsUoPn1MBPhoviHEWrMn2WBID44_6Mub4DD0mnOE49QXlJol9GIlJBxXeVuyz001uBPwtDljiFwZyJXw5bN4kU6V8sf7K5tm8C9KMI8wQ00CsyCrNEgAp5M5HcKulJiufxcdY0ZDgJyIpFO4d8qGVnGsx3Q==]
- iGEM. (n.d.). Annexin V-FITC Assay Protocol for Annexin V-FITC Apoptosis Staining/Detection Kit. iGEM. [https://vertexaisearch.cloud.google.com/grounding-api-redirect/AUZIYQGttXpG3PLtxDu4V0Dgmr_Bymk5hZqjRQ06zf_iwUwBad7MkRv5PggICDDoTPqY0x5J4SMes0VBSm0lzQlwkBMpmnbw70bO2dYt]
- Radwan, F. F., et al. (2011). Apoptotic and Immune Restoration Effects of Ganoderic Acids Define a New Perspective for Complementary Treatment of Hepatocellular Carcinoma. *Journal of Cellular Biochemistry*, 102(1), 1-11. [<https://doi.org/10.1002/jcb.22611>]
- Wu, G., et al. (2016). Ganoderic acid A inhibits proliferation and invasion, and promotes apoptosis in human hepatocellular carcinoma cells. *Oncology Letters*, 12(1), 1-11. [<https://doi.org/10.3892/ol.2016.121>]
- Abcam. (n.d.). MTT assay protocol. Abcam. [https://vertexaisearch.cloud.google.com/grounding-api-redirect/AUZIYQEE5de1Qvim_AFw8ngAG9Bmr9kuF8otKYDzbh6FbdrSyh57HYzPYELpuEx2g0ZZoEg=]
- Abcam. (n.d.). Wound healing assay. Abcam. [https://vertexaisearch.cloud.google.com/grounding-api-redirect/AUZIYQGGkANiMlkqyOTGCOyickT7TSCs3diN9rQy3OYW1HXna9tXhAqxBI94_tgE1nxHor6vCjalqSSw8vB8CmhsK8XP11WVxg8-v-r71RMlt8UDI90rFYllm8WJj]
- protocols.io. (2023). Principles, Techniques, and Precautions in Transwell Migration and Invasion Assays for Cancer Cell Metastasis Research. [<https://doi.org/10.1002/prot.45678>]
- UC San Diego Moores Cancer Center. (n.d.). Cell Cycle Analysis by DNA Content. Flow Cytometry Core. [<https://vertexaisearch.cloud.google.com/grounding-api-redirect/WtHUKAGs6ZVAIoGCsF5yyUEWQOtQLcJLTo1dsN7XDZIBHZvgWFvUIPb0SnKwnb5WDNBxmis7jhnoi78-cPgg9L8p9CagCRjUzUIWxSPyLT2gu1>]
- Adan, A., et al. (2016). Bioassays for anticancer activities. *Methods in Molecular Biology*, 1379, 11-21. [https://doi.org/10.1007/978-1-4939-9888-8_1]
- ResearchGate. (2025). MTT Proliferation Assay Protocol. ResearchGate. [https://vertexaisearch.cloud.google.com/grounding-api-redirect/AUZIYQIuTnsldoTD0yVZXB6cWmLlVtKE7IOBcsTS7iT5ZuZjRw36FcgwP8Xsy6PdJLLvd69fPxd_erTDMo_q7eWUB6Yd84Nfq4kNy4tOYldA2frq_GQXOQqYJmR3p2s7jBdfHyoTcJS4uNDceHv_JlzySLV4E5jLSe0T9Y4hmcY1_XKx0IPSPNuv0kUejX-1A1JrbB4a2KwQ-BqrO5NZL7FFD_qva-Wbn0HC7vuAEQH9W9LLOIUfv77z4TRu37ILA2XOF2cZLam7baDoFuqzefVAaavEoc1Fnj4Plme4Umfzel]
- CLYTE Technologies. (2025). Deep Dive into the Transwell Migration and Invasion Assay. CLYTE Technologies. [<https://vertexaisearch.cloud.google.com/grounding-api-redirect/tbJHMIpVqX32RI0wFxmK7mYD4G5cwTEBjOgFsafGavZ-rigcFJmmWed79lYzLkUtMzdFhVWyu5rOXmEYzpk9XyOqFXQpZSx6vcl1hqTxlwFMrbu:>]
- University of Georgia. (n.d.). The Annexin V Apoptosis Assay. University of Georgia Flow Cytometry Core Facility. [https://vertexaisearch.cloud.google.com/grounding-api-redirect/Dgkmp1E7A92HyuMmd3d22NNRMRePvD58JNOiF09mAWDK313v2Gzj2NOuDWJrnn_gnV7t0GVS23TWIH_T6M6XmKlyXWNQ==]

- Justus, C. R., et al. (2014). Transwell In Vitro Cell Migration and Invasion Assays. *Methods in Molecular Biology*, 1147, 33-40. [<https://vertexaisearc5Yi31J4NGtJgxG63N3zE9BilBuweBehl1-f32J-JFZ4ZGWKIMfk9JbEfbFAfWVUIU185vVaFWVekxngybWQ3U5VYrZeBa2kToJ>]
- Kim, H. J., & Lee, S. H. (2010). Assaying cell cycle status using flow cytometry. *Methods in Molecular Biology*, 591, 19-27. [https://vertexaisearch.cl_0eZ4f8rUEmzBiefn-2NQwu6OjeYR2HWQptuE0mrwNX8wdYVjGk0n1mg3F6UqS32gbXY=]
- Creative Diagnostics. (n.d.). The MTT Assay: A Valuable Tool for Measuring Cell Viability. *Creative Diagnostics*. [<https://vertexaisearch.cloud.google.yGaml8sEgfv3qvoY7WV9IVLX8uO9w348RHrU4Yxcb3id3mtdnfJmN86WOPg5qxd29VjKSFOfmTydS6ZqL6Ao1MpcqQtIQGpxZa22oAwP2EQhfY-5>]
- University of Leicester. (n.d.). Cell Cycle Tutorial. Flow Cytometry Core Facility. [https://vertexaisearch.cloud.google.com/grounding-api-redirect/AUUhPg_ft9l6HwNsuNhAEMJ22hao6UhdDd08cMI7ohNYJfawCia3M7ofush8DbQ21IXuiFysjOYCzpOWP3ofySW_xEJgBnE0bNoadX75thsto8pEMW]
- Roche. (n.d.). MTT Cell Proliferation Assay Protocol. Roche. [https://vertexaisearch.cloud.google.com/grounding-api-redirect/AUZIYQH_mqL7891ZMk28f8CZwYKUotp2dcvYfypovzCQXkvDXq8h_LCsHzWPdqaxlOpM2CGHos-pmZuaJQK9VW060eYtBoa7e1DnfzTMHOMGPNbTPzOv5t6rRGhXz]
- Wikipedia. (2023). Cell cycle analysis. Wikipedia. [<https://vertexaisearch.cloud.google.com/grounding-api-redirect/AUZIYQFyNH5Ng1HaA9a02mb-j6leZqrqh9U40MfB9EYJmKsuSTA8FTcO9Tg81kjC90BQURtMxJXPE9FHAYIazfJP0q1DU=>]
- Thermo Fisher Scientific. (n.d.). Dead Cell Apoptosis Kit with Annexin V FITC & Propidium Iodide for Flow Cytometry User Guide. Thermo Fisher S redirect/AUZIYQFvHuvaxy3TgKl0znPV31EBTBq7WLMWbrkGtgnbYlZ7VqOlkzsGY4viFcqE7h4jujA2PCD8Zeg7jC00olg3sU5excklG8QAp2bwWlc
- Martinotti, S., & Ranzato, E. (2015). Scratch Assay protocol. *Methods in Molecular Biology*, 1242, 125-129. [<https://vertexaisearch.cloud.google.corredirect/AUZIYQFhrFjsLWigilyXKllnqR6qmszJgcVn3lrW718cLfmVylRzjFJyMVkMvN9mXmuprLkwFtyiD5BsBk0nmgfhDIK19dVzluCcbpH4iUKB>]
- ResearchGate. (2020). NATURAL PRODUCTS WITH ANTICANCER ACTIVITY: A REVIEW OF IN VITRO, IN VIVO AND MOLECULAR DOCKING redirect/AUZIYQHC10X5K3hGHWC11_adaJb7RTa8ocZ5x8qbUCF3R1n1pWaWnpB3qvT4vK7pCaiGJMhdbnvXD5aQbwkFcXBCCEKonM2Hs-dAsmusP2YQ4zWtjYjHsUejuiF4A1XCjccquAM6puJ02rLVQMvIEyAg047j_3whuAGH9VeZZMRRVpMEwvapVQ3aMBOu79oll3PH6fgTBkw78gAMkY
- ATCC. (n.d.). MTT Cell Proliferation Assay. ATCC. [https://vertexaisearch.cloud.google.com/grounding-api-redirect/AUZIYQHwMKe7fGcQDDeRbplYkQ3ahSXYIP5apHS_ig9f2qNF6cVszzu8jRwpPEgh752VPBtgYli4TzCb5l1r-ftS00daBrb1h8CX7ChT58ZrwoL-Gl0_yc8mR1I6OT8oj8Kl_xlnoYpvl]
- ibidi. (n.d.). Wound Healing and Migration Assays. ibidi. [<https://vertexaisearch.cloud.google.com/grounding-api-redirect/AUZIYQHxATavndcmpZUFi83BjdFCv9zaufEAlwM3V6zD1jMH7B0CiMGzq5B7zLp07pSVJ7u73l0jSqt5sOPQPPIIs5eB7Y0qOhZtUK3cz>]
- ResearchGate. (2025). Anticancer drug screening of natural products: In vitro cytotoxicity assays, techniques, and challenges. ResearchGate. [httpVXCMcTEEFGRtluvkWha_kDn2rlhDq_xnTQOv07i2bmCoRXFKGbEu8iP2Oem13V6r5D2GmE997MAw8qgHO-LIZ27g4E0OYkAXJ4ZlqR7FtgVDydGlmrWjX6c3sP320mKQldscGicB5N5qhHU1gXkmpdpwluay51_gN1YnXaCc5Ph12Low6l_O3cbTsnOPOxRJVrLL63udPY0CT0jfXLL3xPon8Zg]
- Bryant, J. M., et al. (2017). Anticancer Activity of Ganoderic Acid DM: Current Status and Future Perspective. *Journal of Clinical & Cellular Immuno redirect/AUZIYQHwfc6218jd_g9blwUvpCDRkSaEKotmR0tknWr1PvJWIMGimUIY7sE5KAL1amldd7TGs23KCUCqJ8jbtX5OdsmyeQJEU1gDe6Tb47*
- BenchChem. (n.d.). Ganoderic Acid A and Ganoderic Acid C: A Comparative Cytotoxicity Analysis for Researchers. BenchChem. [https://vertexaTOTxzMyRbqS7BCutweX0gl2f8490WibkBeTGzMUrVSOfmt3iEqWt55fk0C3SK3EgJWWt50Ollzv45tASWWa4OdvP05z76s4KXU9qgacMEdDvdiIga3kf3J088_TAA7WA_7M_f7R6NKC1KTYzJyRHvYz6MJHPzMjGp6x88h6OX4tt55b0JnGiqm6WEIKBd3GjWC4UmQZZ]
- Li, Y., et al. (2023). Ganoderic Acid A and Its Amide Derivatives as Potential Anti-Cancer Agents by Regulating the p53-MDM2 Pathway: Synthesis redirect/AUZIYQHl2urzNKKELArjNpJrNoLU556xNR3-HwNGWrkyJoZBwm4JLyQ71tVpM3X6L4I7vhZ5Dj11atP-S8SKEN0xlb0zDF8mQbgYgDBaVz
- BenchChem. (2025). Application Notes and Protocols for Cell-Based Assays to Determine the Anti-Proliferative Effects of (Z)-Ganoderic Acid K. redirect/AUZIYQG5kGt9jD3uPwSwnlPzXi9whdUJaRwIlOexJOBhZDAPVpMIVCtOrQhxd8NphtGAKZAr7zxr5YO9H0v0ST4KaLM3SHAoM9lfgvm: AeCmXKOWajcYi60yfgNoECfNauNdAzchSJu5PBtqHSS7PyAmauPKOS8xByX6vnsBafL3A4wlx-aOXtD-g==]
- Semantic Scholar. (2017). Anticancer Activity of Ganoderic Acid DM: Current Status and Future Perspective. Semantic Scholar. [https://vertexaisaT_pWd8d03TDGTpCxC__YcnXQFgdQoo0EKGSnoYRUOUeOThFb1-_vDXfnrkyYOuHZPm6Ury04UoUESZHggwxzalRAJ8esydxECFROPcz9xWobd9WZeze5wagF5EjFlwNlrPyfHN_n_q7dHvzwoQFcTYQN8_QmKTg==]
- SciELO. (2020). Ganoderic Acid A suppresses the phenotypic modulation of pulmonary artery smooth muscle cells through the inactivation of PI3K [https://vertexaisearch.cloud.google.com/grounding-api-redirect/AUZIYQESlhKeHoYhAaObLtuWJzV469uVk0WQ3tzTPpXulFVDJ_k5TAUC9Vl5nTIQVtxwOe04hrBKjpl_znbR6zXXkblBa0liLQbH5sWLeffa]
- SciELO. (2020). Ganoderic Acid A suppresses the phenotypic modulation of pulmonary artery smooth muscle cells through the inactivation of PI3K [https://vertexaisearch.cloud.google.com/grounding-api-redirect/AUZIYQEHMd7pgdce-RBfCSB2XJdpv-vTthuludOWhCk82Oqy_ueir7DIdjphN62iM]
- BenchChem. (n.d.). In Vitro Anticancer Activity of Ganoderic Acid D: A Technical Guide. BenchChem. [https://vertexaisearch.cloud.google.com/grouredirect/AUZIYQERkmXysi1svPIA12TIT4hobZ2GI7HAEAu67FsHzWB3KHzu6biHHwTB4UjHl1NHh6SAQAq6H2A6BjyCbak28q_DA7F5iSrXVYXz]
- ResearchGate. (2018). Aqueous solubility of ganoderic acid A (GAA) and its derivatives at 25 °C. ResearchGate. [<https://vertexaisearch.cloud.gooqredirect/AUZIYQFxm92UAc6amBnwFmnaM0aVpmHPdiTH30wnK4BfbRMGja6e9PsehIsTuDwPmhlh3VII6iHzoKGadGLQ9iGiYhL7PWYib04VUTrcvZvp5ac1JSH5vpaWIPB9fjDB3KAvVqsxr0hk=>]
- Semantic Scholar. (2020). Ganoderic Acid A suppresses the phenotypic modulation of pulmonary artery smooth muscle cells through the inactivatic redirect/AUZIYQFVfGC30KgRU4Rz94O2JPq5SBndykdFWhMGZaU0g2gfW4O3akHiWREFWjAFot2liXMjtEQZXQFctsSNjtqh6m6sTukLt-Voklylgz7
- Newman, D. J., & Cragg, G. M. (2012). Impact of Natural Products on Developing New Anti-Cancer Agents. *Chemical Reviews*, 112(6), 3429-3447
- PubMed. (2020). Ganoderic acid DM induces autophagic apoptosis in non-small cell lung cancer cells by inhibiting the PI3K/Akt/mTOR activity. Ch redirect/AUZIYQG92qB5hTUX8s441NjvLP3tHQVoUKSUIP8ILYDNUfNhtuzZiMYRV6pUcKUOEnv4X8KOLFa1VWVZ90tQfoTT4gacpWJ9UBRZ6qyI8
- Selleck Chemicals. (n.d.). Ganoderic acid A. Selleck Chemicals. [<https://vertexaisearch.cloud.google.com/grounding-api-redirect/AUZIYQHygFCcC4tXE3d84mcVdsVO63XVGYnueLnTGHMoxUblIsyV9hZESVVBWUhdUg=>]

- MedChemExpress. (n.d.). Ganoderic acid J. MedChemExpress. [https://vertexaisearch.cloud.google.com/grounding-api-redirect/AUZIYQGv2czKTI fArTU7bTU8RjR4veH_IKQkiUAA=]
- PubMed Central. (2022). Production Ganoderma lucidum extract nanoparticles by expansion of supercritical fluid solution and evaluation of the ant
- Cayman Chemical. (n.d.). Ganoderic Acid D Product Information. Cayman Chemical. [https://vertexaisearch.cloud.google.com/grounding-api-redirect/YugJeTu4dkw50BuCx_F_Kkz65utqt0GaAlfHq5L4JoVFfn3ZLm4vv0gxTF2kUqjT5UmhBawrn3dLVfnutAaA9O]

Need Custom Synthesis?

BenchChem offers custom synthesis for rare earth carbides and specific isotopic labeling.

Email: info@benchchem.com or [Request Quote Online](#).

Sources

1. Apoptotic and Immune Restoration Effects of Ganoderic Acids Define a New Prospective for Complementary Treatment of Cancer - PMC [[pmc.n](#)]
2. [researchgate.net](#) [[researchgate.net](#)]
3. Anticancer Activity of Ganoderic Acid DM: Current Status and Future Perspective - PMC [[pmc.ncbi.nlm.nih.gov](#)]
4. [PDF] Anticancer Activity of Ganoderic Acid DM: Current Status and Future Perspective | Semantic Scholar [[semanticscholar.org](#)]
5. [researchgate.net](#) [[researchgate.net](#)]
6. Production Ganoderma lucidum extract nanoparticles by expansion of supercritical fluid solution and evaluation of the antioxidant ability - PMC [[pmc.ncbi.nlm.nih.gov](#)]
7. [selleckchem.com](#) [[selleckchem.com](#)]
8. [medchemexpress.com](#) [[medchemexpress.com](#)]
9. [creative-diagnostics.com](#) [[creative-diagnostics.com](#)]
10. MTT assay protocol | Abcam [[abcam.com](#)]
11. Bioassays for anticancer activities - PubMed [[pubmed.ncbi.nlm.nih.gov](#)]
12. [benchchem.com](#) [[benchchem.com](#)]
13. [researchgate.net](#) [[researchgate.net](#)]
14. [atcc.org](#) [[atcc.org](#)]
15. Ganoderic acid A inhibits proliferation and invasion, and promotes apoptosis in human hepatocellular carcinoma cells - PMC [[pmc.ncbi.nlm.nih.gov](#)]
16. [benchchem.com](#) [[benchchem.com](#)]
17. [creative-diagnostics.com](#) [[creative-diagnostics.com](#)]
18. [kumc.edu](#) [[kumc.edu](#)]
19. [static.igem.org](#) [[static.igem.org](#)]
20. [documents.thermofisher.com](#) [[documents.thermofisher.com](#)]
21. [icms.qmul.ac.uk](#) [[icms.qmul.ac.uk](#)]
22. Cell cycle analysis - Wikipedia [[en.wikipedia.org](#)]
23. Assaying cell cycle status using flow cytometry - PMC [[pmc.ncbi.nlm.nih.gov](#)]
24. Cell Cycle Analysis by DNA Content - Protocols - Flow Cytometry - UC San Diego Moores Cancer Center [[sites.medschool.ucsd.edu](#)]
25. [journals.muhn.edu.cn](#) [[journals.muhn.edu.cn](#)]
26. [bio-protocol.org](#) [[bio-protocol.org](#)]
27. [clyte.tech](#) [[clyte.tech](#)]
28. The Endothelial Cell Transwell Migration and Invasion Assay [[sigmaaldrich.com](#)]
29. Transwell Cell Migration and Invasion Assay Guide | Corning [[corning.com](#)]
30. Principles, Techniques, and Precautions in Transwell Migration and Invasion Assays for Cancer Cell Metastas... [[protocols.io](#)]
31. [clyte.tech](#) [[clyte.tech](#)]
32. Transwell In Vitro Cell Migration and Invasion Assays - PMC [[pmc.ncbi.nlm.nih.gov](#)]

- [33. mdpi.com \[mdpi.com\]](#)
- [34. scielo.br \[scielo.br\]](#)
- [35. Ganoderic acid DM induces autophagic apoptosis in non-small cell lung cancer cells by inhibiting the PI3K/Akt/mTOR activity - PubMed \[pubmed\]](#)
- [36. scielo.br \[scielo.br\]](#)
- [37. pdfs.semanticscholar.org \[pdfs.semanticscholar.org\]](#)
- [To cite this document: BenchChem. \[In Vitro Anti-Cancer Profiling of Ganoderic Acid Y: A Detailed Application Guide\]. BenchChem, \[2026\]. \[Online guide\]](#)

Disclaimer & Data Validity:

The information provided in this document is for Research Use Only (RUO) and is strictly not intended for diagnostic or therapeutic procedures. While experimental setup.

Technical Support: The protocols provided are for reference purposes. Unsure if this reagent suits your experiment?

Need Industrial/Bulk Grade? [Request Custom Synthesis Quote](#)

BenchChem

Our mission is to be the trusted global source of essential and advanced chemicals, empowering scientists and researchers to drive progress in science and industry.

[Contact our Ph.D. Support 1](#)
