

Fak-IN-9 solubility issues and solutions

Author: BenchChem Technical Support Team. **Date:** April 2026

Compound of Interest

Compound Name: *Fak-IN-9*
Cat. No.: *B12388619*

[Get Quote](#)

Technical Support Center: Fak-IN-9

Welcome to the technical support center for **Fak-IN-9**, a potent inhibitor of Focal Adhesion Kinase (FAK). This guide provides essential information on solubility, experimental protocols, and troubleshooting to ensure the successful use of **Fak-IN-9** in your research.

Frequently Asked Questions (FAQs) and Troubleshooting

Q1: What is the recommended solvent for preparing **Fak-IN-9** stock solutions?

A1: The recommended solvent for **Fak-IN-9** is dimethyl sulfoxide (DMSO). It is sparingly soluble in ethanol. For optimal results, prepare a high-concentration stock solution in DMSO.

Q2: My **Fak-IN-9** is not dissolving completely in DMSO. What should I do?

A2: If you encounter solubility issues in DMSO, you can try the following:

- Gentle Warming: Warm the solution briefly at 37°C.
- Vortexing/Sonication: Vortex the solution for a few minutes or sonicate the vial in a water bath for 10-30 minutes to aid dissolution.[1]

- Ensure Anhydrous DMSO: Moisture in DMSO can sometimes affect the solubility of compounds. Use high-quality, anhydrous DMSO.

Q3: Can I use solvents other than DMSO?

A3: While DMSO is the primary recommendation, **Fak-IN-9** also shows some solubility in ethanol. However, its solubility in ethanol is significantly lower than in DMSO. If your experimental setup is intolerant to DMSO, ethanol may be an alternative, but you will be limited to lower concentrations. Always ensure the final concentration of any organic solvent is non-toxic to your cells, typically below 0.5% and preferably under 0.1%.[\[1\]](#)

Q4: My **Fak-IN-9** precipitated when I diluted the DMSO stock solution into my aqueous cell culture medium. How can I prevent this?

A4: Precipitation upon dilution into aqueous buffers or media is a common issue with hydrophobic compounds. Here are some strategies to prevent this:

- Final DMSO Concentration: Ensure the final concentration of DMSO in your culture medium is as low as possible (ideally $\leq 0.1\%$) to avoid solvent effects on your cells.[\[1\]](#)
- Rapid Mixing: When adding the DMSO stock to your aqueous medium, ensure rapid and thorough mixing. Gently swirl the tube or plate as you add the stock solution.[\[1\]](#)
- Two-Step Dilution: Perform a serial dilution. First, dilute the high-concentration DMSO stock into a smaller volume of medium, vortex gently, and then add this intermediate dilution to your final volume.
- Warm the Medium: Using a pre-warmed (37°C) medium can sometimes help maintain solubility during dilution.[\[1\]](#)
- Presence of Serum/Protein: The presence of proteins, such as those in fetal bovine serum (FBS), can help stabilize the compound and prevent precipitation. Whenever possible, perform dilutions in a complete medium containing serum.

Q5: What are the recommended storage conditions for **Fak-IN-9** powder and stock solutions?

A5:

- Powder: Store the solid form of **Fak-IN-9** at -20°C for long-term stability.
- In Solvent: Once dissolved in DMSO, aliquot the stock solution into smaller, single-use vials to avoid repeated freeze-thaw cycles and store at -80°C for up to one year.[2] Before use, thaw the vial and ensure the compound is fully dissolved.

Solubility Data

The solubility of **Fak-IN-9** in common laboratory solvents is summarized below. Please note that these values are approximate and can vary between different batches and suppliers.

Solvent	Concentration (mg/mL)	Concentration (mM)
DMSO	≥ 53.33	≥ 100
Ethanol	≥ 2.67	≥ 5
PBS (pH 7.2)	Insoluble	Insoluble

Molecular Weight of **Fak-IN-9**: 533.65 g/mol

Experimental Protocols

Protocol 1: Preparation of a 100 mM **Fak-IN-9** Stock Solution in DMSO

- Preparation: Allow the vial of **Fak-IN-9** powder to equilibrate to room temperature before opening.
- Calculation: To prepare a 100 mM stock solution, you will need to add a specific volume of DMSO. For example, to a 5 mg vial of **Fak-IN-9** (MW: 533.65 g/mol), add 93.7 µL of high-quality, anhydrous DMSO.
 - Calculation: $(5 \text{ mg} / 533.65 \text{ g/mol}) / 0.1 \text{ mol/L} = 0.0937 \text{ mL} = 93.7 \text{ µL}$
- Dissolution: Add the calculated volume of DMSO to the vial. Cap the vial tightly and vortex thoroughly until the powder is completely dissolved. If necessary, use gentle warming (37°C) or sonication to aid dissolution.

- Storage: Aliquot the stock solution into single-use tubes and store at -80°C.

Protocol 2: Diluting Fak-IN-9 Stock Solution for Cell-Based Assays

- Thawing: Thaw a single-use aliquot of the 100 mM **Fak-IN-9** DMSO stock solution and allow it to reach room temperature.
- Pre-warm Medium: Warm your complete cell culture medium (containing serum, if applicable) to 37°C.
- Intermediate Dilution (Optional but Recommended): Prepare an intermediate dilution of **Fak-IN-9** in your pre-warmed medium. For example, to achieve a final concentration of 10 µM, you could first dilute the 100 mM stock 1:100 in the medium to get a 1 mM intermediate solution.
- Final Dilution: Add the required volume of the stock or intermediate solution to your cell culture plates containing pre-warmed medium to achieve the desired final concentration. Ensure that the final DMSO concentration does not exceed 0.5% (v/v) to avoid solvent toxicity.

Visualizations

Fak-IN-9 Mechanism of Action

Fak-IN-9 is a potent inhibitor of Focal Adhesion Kinase (FAK), a non-receptor tyrosine kinase that plays a crucial role in cell signaling pathways.[3][4] FAK is activated by integrins and growth factor receptors, and it regulates key cellular processes such as cell proliferation, survival, and migration.[5][6][7] By inhibiting FAK, **Fak-IN-9** disrupts these signaling cascades.

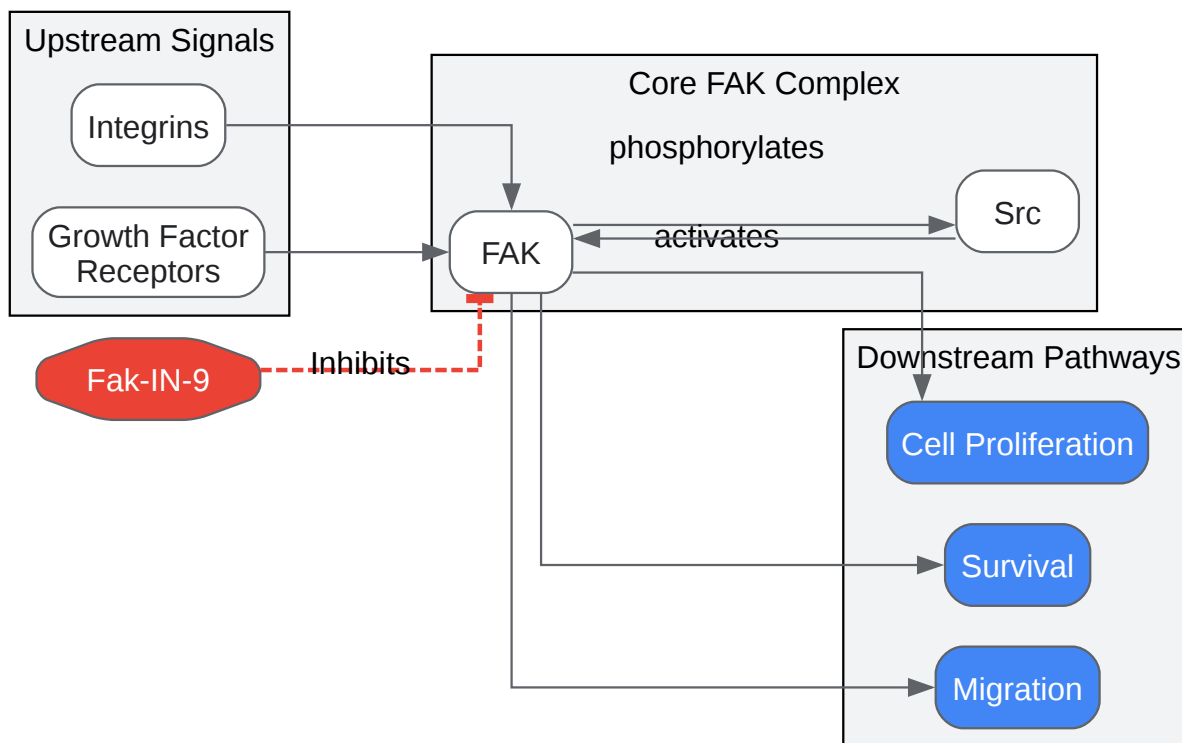

[Click to download full resolution via product page](#)

Caption: Simplified FAK signaling pathway and the inhibitory action of **Fak-IN-9**.

Troubleshooting Workflow for Solubility Issues

If you encounter issues with **Fak-IN-9** solubility, follow this troubleshooting workflow.

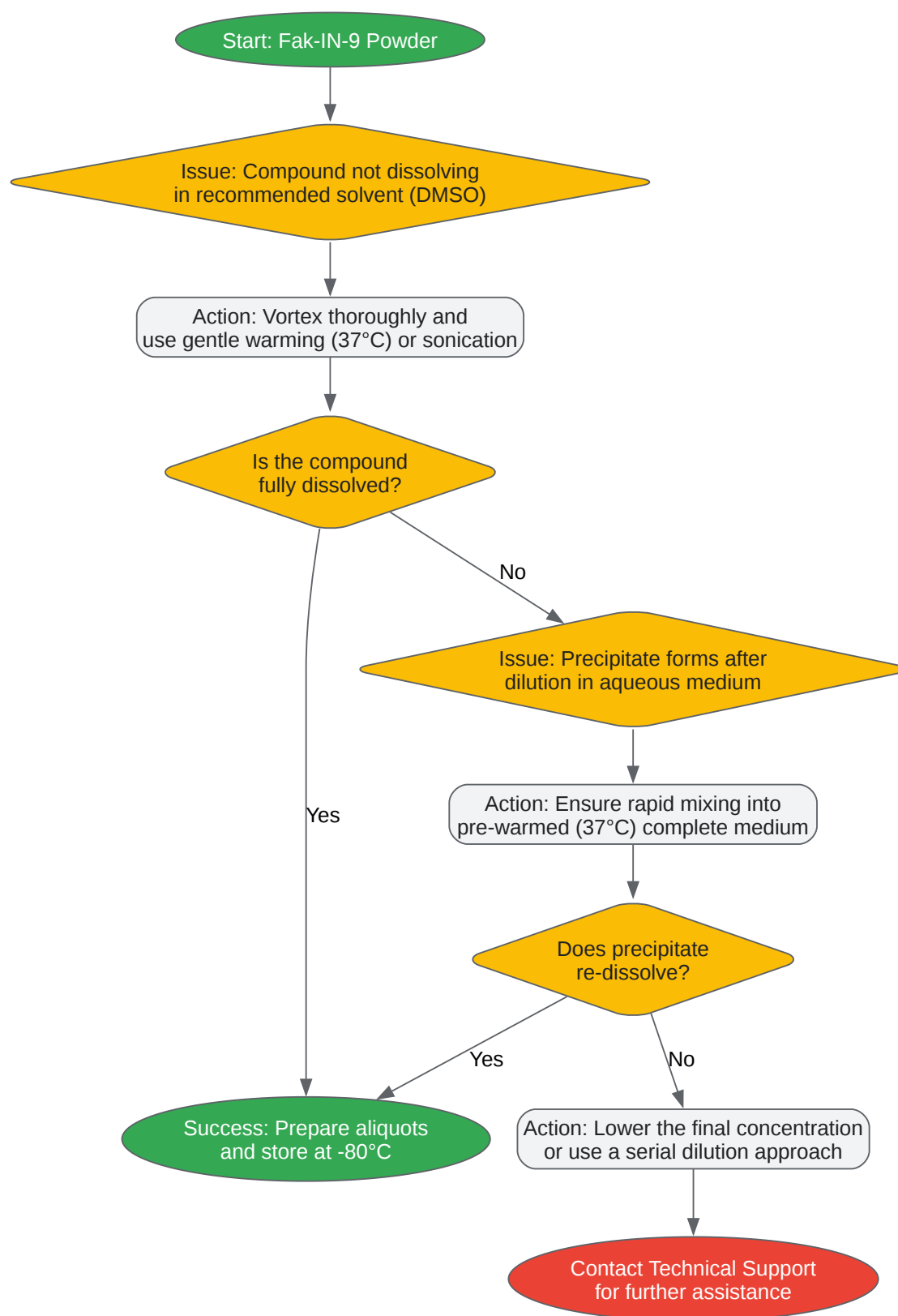

[Click to download full resolution via product page](#)

Caption: A step-by-step workflow for troubleshooting common **Fak-IN-9** solubility issues.

Need Custom Synthesis?

BenchChem offers custom synthesis for rare earth carbides and specific isotopic labeling.

Email: info@benchchem.com or [Request Quote Online](#).

References

- [1. emulatebio.com \[emulatebio.com\]](https://emulatebio.com)
- [2. FAK-IN-17_TargetMol \[targetmol.com\]](https://targetmol.com)
- [3. Signaling through focal adhesion kinase - PubMed \[pubmed.ncbi.nlm.nih.gov\]](https://pubmed.ncbi.nlm.nih.gov)
- [4. FAK-Src Signaling Pathway: Tyrosine Kinases in Cell Migration & Cancer Progression - Creative Biolabs \[creativebiolabs.net\]](https://creativebiolabs.net)
- [5. aacrjournals.org \[aacrjournals.org\]](https://aacrjournals.org)
- [6. Focal adhesion kinase and its signaling pathways in cell migration and angiogenesis - PMC \[pmc.ncbi.nlm.nih.gov\]](https://pmc.ncbi.nlm.nih.gov)
- [7. Signal Transduction Mechanisms of Focal Adhesions: Src and FAK-Mediated Cell Response \[imrpess.com\]](https://imrpess.com)
- To cite this document: BenchChem. [Fak-IN-9 solubility issues and solutions]. BenchChem, [2026]. [Online PDF]. Available at: [\[https://www.benchchem.com/product/b12388619/docs#fak-in-9-solubility-issues-and-solutions\]](https://www.benchchem.com/product/b12388619/docs#fak-in-9-solubility-issues-and-solutions)

Disclaimer & Data Validity:

The information provided in this document is for Research Use Only (RUO) and is strictly not intended for diagnostic or therapeutic procedures. While BenchChem strives to provide accurate protocols, we make no warranties, express or implied, regarding the fitness of this product for every specific experimental setup.

Technical Support: The protocols provided are for reference purposes. Unsure if this reagent suits your experiment?

Need Industrial/Bulk Grade? [Request Custom Synthesis Quote](#)

BenchChem

Our mission is to be the trusted global source of essential and advanced chemicals, empowering scientists and researchers to drive progress in science and industry.

Contact

Address: 3281 E Guasti Rd

Ontario, CA 91761, United States

Phone: (601) 213-4426

Email: info@benchchem.com

[Contact our Ph.D. Support Team for a compatibility check](#)