

Application Notes and Protocols for Thermoelectric Generators in Remote Power Generation

Author: BenchChem Technical Support Team. **Date:** April 2026

Compound of Interest

Compound Name: G43-C3-TEG

Cat. No.: B12388539

[Get Quote](#)

For Researchers, Scientists, and Drug Development Professionals

These application notes provide a comprehensive overview of the use of Thermoelectric Generators (TEGs) for remote power generation. The content covers key applications, performance data, and detailed experimental protocols for characterization and validation.

Introduction to Thermoelectric Generators (TEGs)

Thermoelectric generators are solid-state devices that convert a temperature difference (thermal energy) directly into electrical energy through a phenomenon known as the Seebeck effect.[1][2] This technology is particularly well-suited for remote power generation due to its high reliability, lack of moving parts, and long, maintenance-free operational life.[3] TEGs are employed in a variety of environments where conventional power sources are impractical, ranging from deep space to terrestrial off-grid locations.[1][3]

Key Applications in Remote Power Generation

TEGs offer a reliable power solution for a multitude of remote applications. Key areas where TEGs are currently utilized or show significant promise are detailed below.

Space Exploration: Radioisotope Thermoelectric Generators (RTGs)

RTGs are a type of nuclear battery that uses the heat from the decay of a radioactive material, typically plutonium-238, to generate electricity via thermocouples. They are a crucial power source for deep-space missions where solar panels are not a viable option.

Key Characteristics:

- **Long Lifespan:** RTGs can provide consistent power for decades, with the power output decreasing predictably with the half-life of the radioisotope fuel.
- **High Reliability:** The absence of moving parts makes them extremely reliable for long-duration, unmaintained missions.
- **Harsh Environment Operation:** RTGs are designed to operate in the vacuum of space and across a wide range of temperatures.

Terrestrial Off-Grid Power

In remote terrestrial locations, TEGs are used to power a variety of low-to-medium power devices.

TEGs are increasingly being used to power wireless sensor networks (WSNs) and Internet of Things (IoT) devices in locations where battery replacement is difficult or impossible. These applications often involve monitoring environmental conditions, industrial processes, or infrastructure.

System Configuration: A typical TEG-powered sensor system includes the TEG module, a heat source (such as waste heat from industrial equipment or natural heat gradients), a heat sink, a power management integrated circuit (PMIC), and an energy storage device (like a supercapacitor or a rechargeable battery).

TEGs provide a reliable source of DC power for impressed current cathodic protection (ICCP) systems, which are used to prevent corrosion in pipelines, wellheads, and other metal structures in remote areas. They are often fueled by natural gas tapped directly from the pipeline they are protecting.

Advantages:

- **Continuous Power:** Unlike solar power, TEGs can provide uninterrupted power, which is critical for effective corrosion prevention.
- **Low Maintenance:** Their solid-state design results in minimal maintenance requirements.

Quantitative Performance Data

The following tables summarize key performance metrics for various TEG applications and materials, providing a basis for comparison.

Table 1: Performance of Radioisotope Thermoelectric Generators (RTGs) in Space Missions

| Mission/RTG Model | Power Output at Beginning of Mission (Watts) | Design Lifetime (Years) | Spacecraft/Application | Reference(s) |
|--|--|-------------------------|---|--------------|
| SNAP-19 (Pioneer) | 40.3 | 5 | Pioneer 10 & 11 | |
| SNAP-19 (Viking) | 42.6 | 0.25 (90 days) | Viking 1 & 2 Landers | |
| SNAP-27 | 70 | 2 | Apollo Lunar Surface Experiments | |
| Multi-Hundred Watt (MHW-RTG) | 158 | >45 (operational) | Voyager 1 & 2 | |
| General Purpose Heat Source (GPHS-RTG) | 292 | >14 (operational) | Galileo, Ulysses, Cassini, New Horizons | |
| Multi-Mission (MMRTG) | ~110 | 14 | Mars Science Laboratory (Curiosity), Mars 2020 (Perseverance) | |
| Next Generation RTG (Mod 1) | ~245 (estimated) | >17 (mission dependent) | Future deep-space missions | |

Table 2: Performance of Commercial TEG Modules for Terrestrial Applications

| TEG Module/System | Hot Side Temperature (°C) | Cold Side Temperature (°C) | Power Output (Watts) | Efficiency (%) | Application | Reference(s) |
|--|---------------------------|----------------------------|----------------------|----------------|-----------------------|--------------|
| Bismuth Telluride (Bi_2Te_3) based | 150 | 50 (approx.) | 1.41 | ~4-5 | Waste Heat Recovery | |
| 6-layer TEG Apparatus | 176 | 24 | 500 | - | Geothermal Field Test | |
| 20-layer TEG Device | 80 | 20 | 150 | 1.72 | Industrial Waste Heat | |
| Forest Soil TEG | 5-15 (ΔT) | - | 0.0037 | 0.011 | Remote Sensing | |
| TEG for Ship ICCP | - | - | 4.43 V, 0.34 A | - | Cathodic Protection | |

Experimental Protocols

This section provides detailed protocols for the characterization of thermoelectric materials and the performance evaluation of TEG modules.

Characterization of Thermoelectric Material Properties

Accurate measurement of a material's thermoelectric properties is crucial for predicting its performance in a TEG. The key parameters are the Seebeck coefficient (S), electrical resistivity (ρ), and thermal conductivity (κ).

This protocol describes a common method for measuring the Seebeck coefficient and electrical resistivity of a bulk material sample.

Materials and Equipment:

- Bar-shaped sample of the thermoelectric material
- Two copper blocks with integrated heaters
- Two Type-T thermocouples
- High-precision voltmeter
- Stable DC current source
- Cryostat or furnace for temperature control
- Thermal paste

Procedure:

- **Sample Preparation:** Cut the thermoelectric material into a rectangular bar of known dimensions.
- **Mounting:** Mount the sample between the two copper blocks, ensuring good thermal contact by applying a thin layer of thermal paste.
- **Thermocouple Placement:** Attach the junctions of the two thermocouples to the sample at a known distance apart. The thermocouple wires can also serve as voltage probes.
- **Seebeck Coefficient Measurement:** a. Establish a stable base temperature for the entire setup using the cryostat or furnace. b. Activate one of the heaters to create a small temperature gradient (ΔT) of a few Kelvin across the sample. c. Measure the temperature at each thermocouple (T_1 and T_2) and the voltage difference (ΔV) between the corresponding voltage leads of the thermocouples. d. The Seebeck coefficient is calculated as $S = -\Delta V / \Delta T$.
- **Electrical Resistivity Measurement (Four-Probe Method):** a. Pass a known DC current (I) through the length of the sample via the outer two probes (current leads). b. Measure the voltage drop (V) across the inner two probes (voltage leads). c. The resistance (R) is calculated using Ohm's law: $R = V / I$. d. The electrical resistivity (ρ) is then calculated using the formula: $\rho = R * (A / L)$, where A is the cross-sectional area of the sample and L is the distance between the inner voltage probes.

Performance Evaluation of a TEG Module

This protocol outlines the procedure for testing the power output and efficiency of a complete TEG module.

Materials and Equipment:

- TEG module
- Controlled heat source (e.g., electric heater, hot plate)
- Heat sink with cooling system (e.g., fan, water block)
- K-type thermocouples
- Variable electronic load
- Multimeter or data acquisition system to measure voltage and current
- Thermal paste or graphite foil
- Clamping mechanism to apply consistent pressure

Procedure:

- Setup Assembly: a. Apply a thin, uniform layer of thermal interface material (thermal paste or graphite foil) to both the hot and cold sides of the TEG module. b. Place the TEG module between the heat source and the heat sink. c. Use the clamping mechanism to apply a consistent and uniform pressure across the module to minimize thermal contact resistance. d. Attach thermocouples to the surfaces of the hot and cold sides of the TEG module to measure the actual surface temperatures (T_h and T_c).
- Open-Circuit Voltage (V_{oc}) Measurement: a. Set the heat source to the desired temperature and activate the cooling system. b. Allow the system to reach a steady state where T_h and T_c are stable. c. Measure the voltage across the TEG output leads with no load connected. This is the open-circuit voltage.

- **Power Output Measurement under Varying Load:** a. Connect the TEG output to the variable electronic load. b. For a fixed temperature difference ($\Delta T = T_h - T_c$), vary the load resistance from a low value to a high value. c. At each resistance setting, measure the corresponding voltage (V) and current (I). d. Calculate the power output (P) at each point using the formula: $P = V * I$. e. Plot the power output as a function of the load resistance to find the maximum power point.
- **Efficiency Measurement:** a. To determine the efficiency, the heat flow through the TEG (Q_{in}) must be measured. This can be done using a heat flux sensor or by calculating the heat dissipated by the cooling system. b. The conversion efficiency (η) is calculated as: $\eta = P_{max} / Q_{in}$, where P_{max} is the maximum power output.

Field Testing Protocol for TEG Systems

This protocol provides a general framework for evaluating the performance of a TEG system in a remote field application.

Procedure:

- **Site Selection and Characterization:** a. Identify a suitable remote location with a reliable heat source (e.g., exhaust from a generator, hot pipe, geothermal vent) and a means for heat dissipation. b. Characterize the thermal environment, including the average temperature of the heat source, ambient temperature fluctuations, and air/fluid flow rates.
- **System Installation:** a. Install the TEG system, ensuring robust mechanical mounting and optimal thermal contact with the heat source and heat sink. b. Integrate the TEG with the power management electronics, energy storage system, and the intended load. c. Install sensors to monitor key parameters: hot and cold side temperatures of the TEG, ambient temperature, TEG output voltage and current, and the state of charge of the energy storage.
- **Data Logging and Performance Monitoring:** a. Implement a data acquisition system to continuously log the sensor data over an extended period (weeks or months) to capture performance under varying environmental conditions. b. Analyze the collected data to determine the total energy generated, system uptime, and the ability of the TEG to meet the power demands of the load.

- Long-Term Reliability Assessment: a. Periodically inspect the TEG system for any signs of degradation, such as corrosion, loosening of mechanical connections, or a significant drop in power output under similar thermal conditions. b. Compare the long-term field performance with the initial laboratory characterization data to assess performance degradation over time.

System Integration and Workflow Diagrams

The following diagrams, generated using Graphviz (DOT language), illustrate the logical workflows and relationships within TEG-based remote power systems.

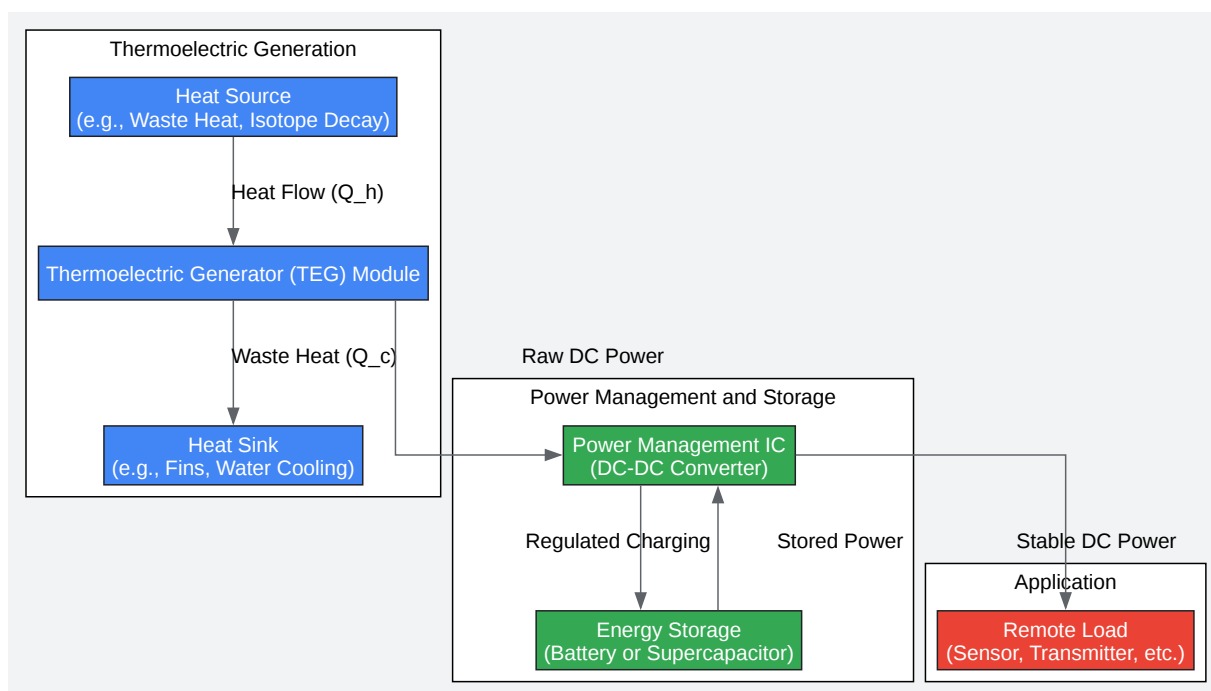

[Click to download full resolution via product page](#)

Diagram 1: Workflow of a TEG-based remote power system.

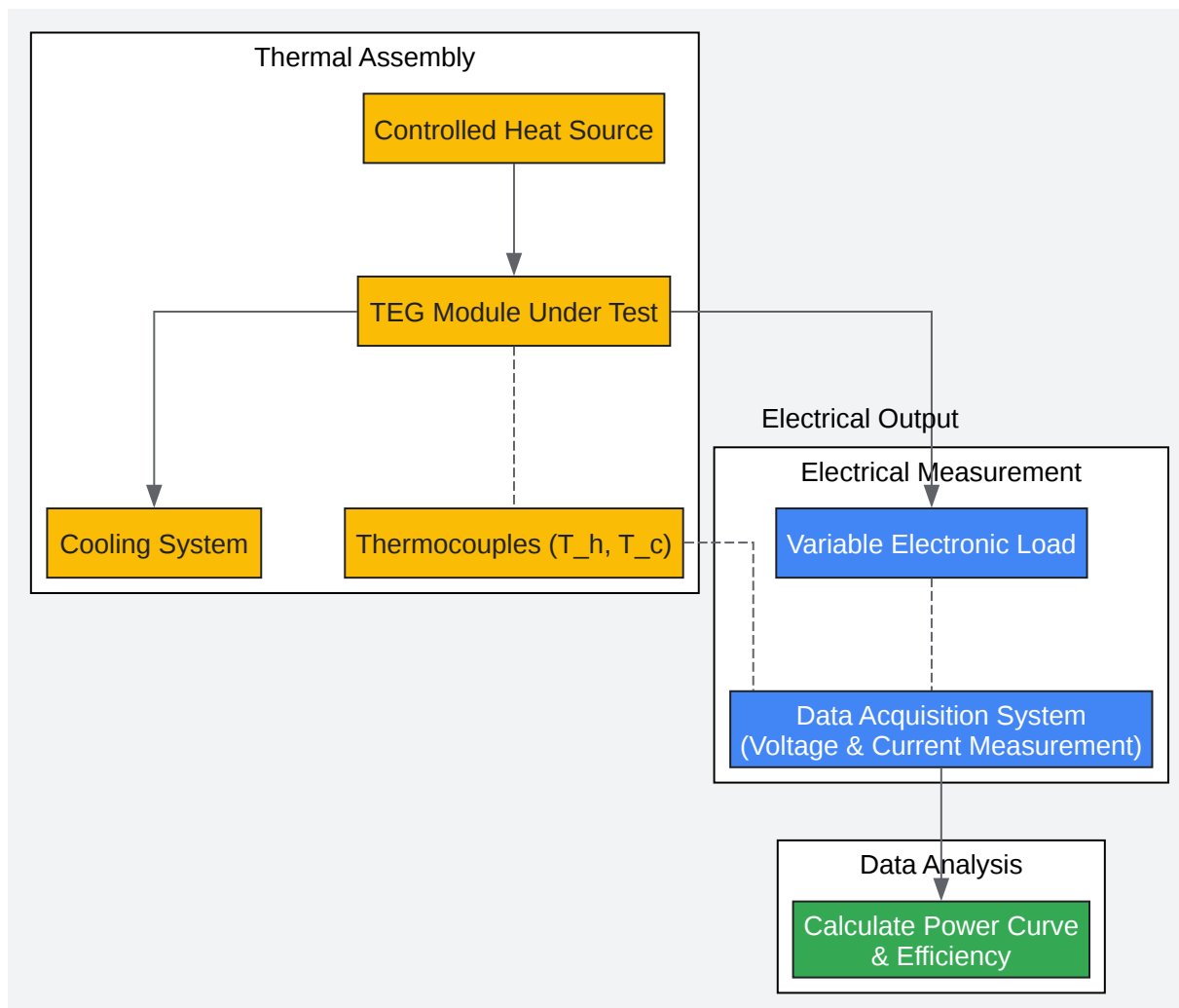

[Click to download full resolution via product page](#)

Diagram 2: Experimental workflow for TEG module characterization.

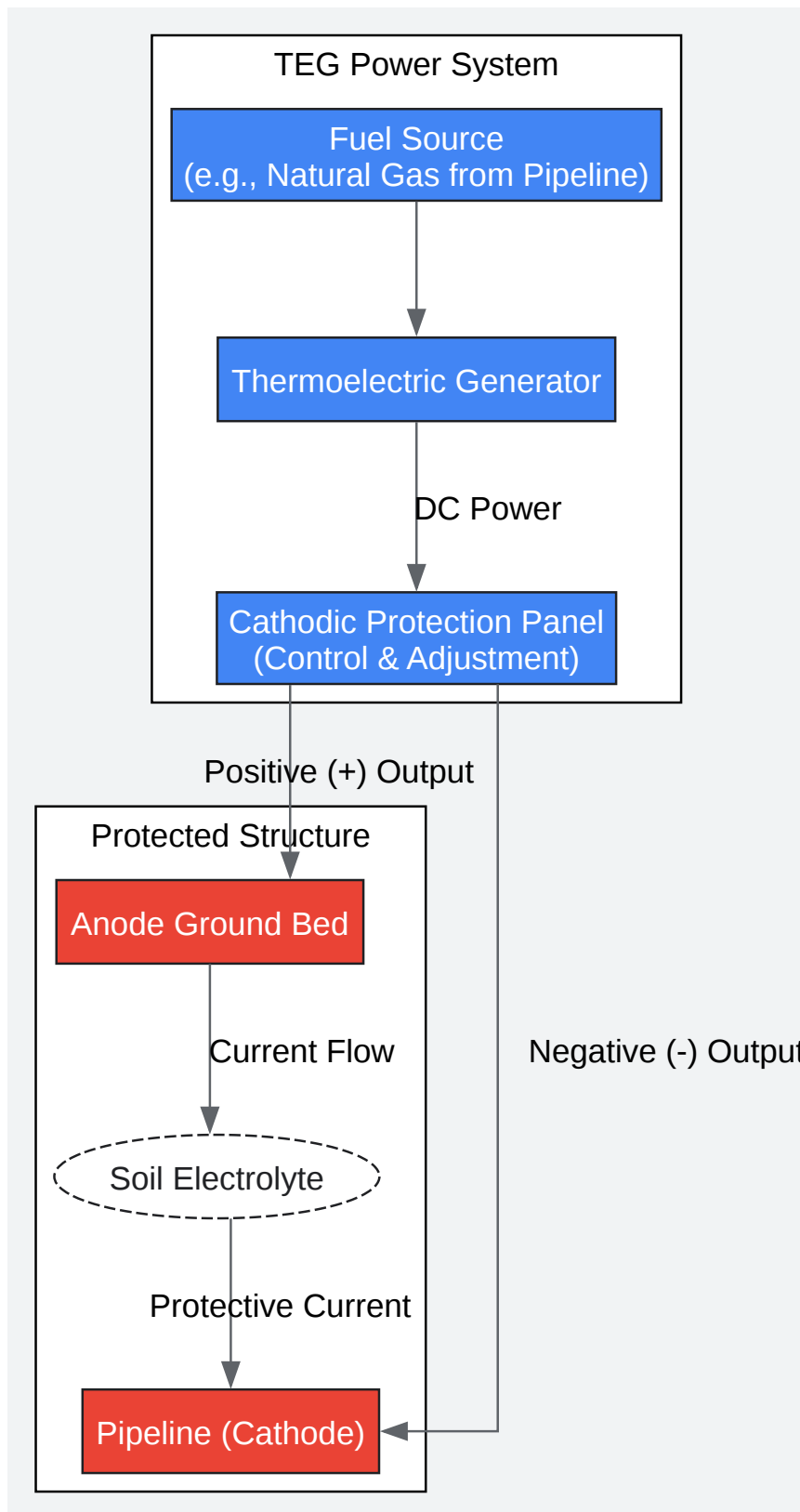

[Click to download full resolution via product page](#)

Diagram 3: Logical relationship in a TEG-powered cathodic protection system.

Need Custom Synthesis?

BenchChem offers custom synthesis for rare earth carbides and specific isotopic labeling.

Email: info@benchchem.com or [Request Quote Online](#).

References

- [1. Comparative Study of Thermoelectric Waste Recovery and Solar Panels \[eureka.patsnap.com\]](#)
- [2. Radioisotope thermoelectric generator - Wikipedia \[en.wikipedia.org\]](#)
- [3. en.eeworld.com.cn \[en.eeworld.com.cn\]](#)
- To cite this document: BenchChem. [Application Notes and Protocols for Thermoelectric Generators in Remote Power Generation]. BenchChem, [2026]. [Online PDF]. Available at: [\[https://www.benchchem.com/product/b12388539/docs#application-notes-and-protocols-for-thermoelectric-generators-in-remote-power-generation\]](https://www.benchchem.com/product/b12388539/docs#application-notes-and-protocols-for-thermoelectric-generators-in-remote-power-generation)

Disclaimer & Data Validity:

The information provided in this document is for Research Use Only (RUO) and is strictly not intended for diagnostic or therapeutic procedures. While BenchChem strives to provide accurate protocols, we make no warranties, express or implied, regarding the fitness of this product for every specific experimental setup.

Technical Support: The protocols provided are for reference purposes. Unsure if this reagent suits your experiment?

Need Industrial/Bulk Grade? [Request Custom Synthesis Quote](#)

BenchChem

Our mission is to be the trusted global source of essential and advanced chemicals, empowering scientists and researchers to drive progress in science and industry.

Contact

Address: 3281 E Guasti Rd

Ontario, CA 91761, United States

Phone: (601) 213-4426

Email: info@benchchem.com

[Contact our Ph.D. Support Team for a compatibility check](#)