

Essential Safety Protocols for Handling High pH Solutions (pH 14)

Author: BenchChem Technical Support Team. **Date:** April 2026

Compound of Interest

Compound Name: PH14
Cat. No.: B12387845

[Get Quote](#)

For Researchers, Scientists, and Drug Development Professionals

This document provides critical safety and logistical guidance for the handling and disposal of solutions with a pH of 14. A pH of 14 indicates a highly alkaline or basic solution, which is extremely corrosive and can cause severe chemical burns to skin and eyes upon contact.^{[1][2][3][4]} Adherence to these protocols is essential to ensure a safe laboratory environment.

Personal Protective Equipment (PPE)

The proper selection and use of Personal Protective Equipment (PPE) is the most critical line of defense against the hazards of high pH solutions.^{[1][5][6]} Below is a summary of the required PPE for handling a pH 14 substance.

PPE Category	Specification	Purpose
Eye Protection	Chemical splash goggles are mandatory. A face shield should be worn in addition to goggles when handling larger volumes or when there is a significant splash risk.[1]	Protects eyes from splashes, which can cause severe and permanent damage.
Hand Protection	Use gloves resistant to strong bases, such as nitrile or neoprene gloves.[1][7] Always check the manufacturer's glove compatibility chart for the specific chemical if known.	Prevents skin contact, which can lead to severe chemical burns.
Body Protection	A chemical-resistant lab coat or apron must be worn over full-length clothing.[1][8] Ensure that no skin is exposed.	Protects the body from spills and splashes.
Footwear	Closed-toe shoes, preferably made of a non-porous material, are required.	Protects feet from spills.
Respiratory	Generally not required if working in a well-ventilated area or a fume hood. If aerosols or mists may be generated, a respirator may be necessary based on a risk assessment.[1]	Protects the respiratory system from inhaling corrosive mists.

Standard Operating Procedures for Handling

1. Preparation and Handling:

- Always handle solutions with a pH of 14 within a certified chemical fume hood to minimize inhalation exposure.[1][6]
- Ensure an eyewash station and safety shower are readily accessible and unobstructed.[6]
- When preparing a diluted alkaline solution, always add the base to water, never the other way around, to avoid a violent exothermic reaction.[5]
- Use appropriate, clearly labeled containers for storage.

2. Spill Response:

- **Small Spills:** Neutralize the spill with a weak acid (e.g., citric acid or a commercial spill kit neutralizer). Absorb the neutralized mixture with an inert material (e.g., sand, vermiculite) and place it in a sealed container for disposal.
- **Large Spills:** Evacuate the immediate area. Alert laboratory personnel and contact the appropriate emergency response team.

3. First Aid:

- **Skin Contact:** Immediately flush the affected area with copious amounts of water for at least 15 minutes while removing contaminated clothing.[1][5][9] Seek immediate medical attention.
- **Eye Contact:** Immediately flush the eyes with water for at least 15 minutes, holding the eyelids open.[1][9] Seek immediate medical attention.
- **Ingestion:** Do NOT induce vomiting. Rinse the mouth with water and drink a large glass of water. Seek immediate medical attention.[4]
- **Inhalation:** Move to fresh air immediately. If breathing is difficult, administer oxygen. Seek medical attention.

Disposal Plan

Highly alkaline waste is considered hazardous and must be neutralized before disposal.[10][11]

Neutralization Protocol:

- Work in a fume hood and wear all required PPE.
- Place the alkaline waste in a large, appropriate container (e.g., borosilicate glass).
- Slowly and carefully add a weak acid (e.g., 1M hydrochloric acid or citric acid) to the alkaline solution while stirring continuously. This process is exothermic and may generate heat.
- Monitor the pH of the solution frequently using a pH meter or pH strips.
- Continue adding the weak acid until the pH is within a neutral range (typically between 6 and 8).
- Once neutralized, the solution can typically be disposed of down the drain with a large volume of water, in accordance with local regulations.[11][12] Always confirm your institution's specific disposal policies.

Safety Workflow Diagram

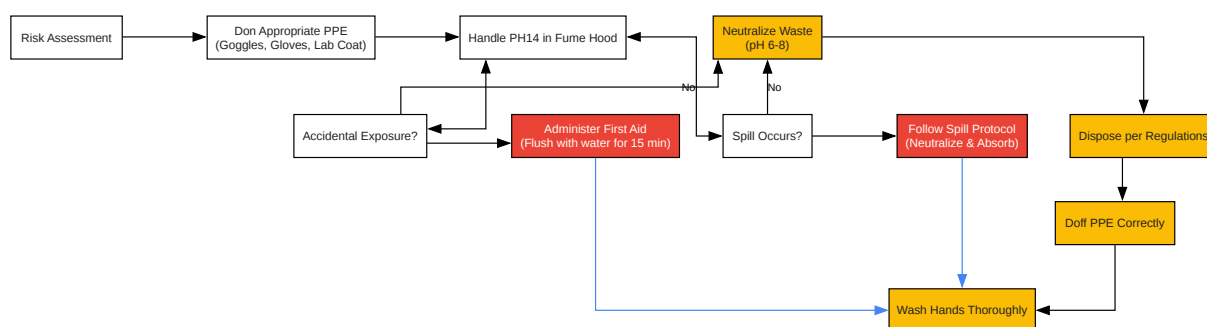

[Click to download full resolution via product page](#)

Caption: Workflow for safely handling and disposing of a pH 14 solution.

Need Custom Synthesis?

BenchChem offers custom synthesis for rare earth carbides and specific isotopic labeling.

Email: info@benchchem.com or [Request Quote Online](#).

References

- [1. Acid & Alkaline – Basic Information for The Safe Handling & Storage of Chemicals - News \[morr.com\]](#)
- [2. quora.com \[quora.com\]](#)
- [3. quora.com \[quora.com\]](#)
- [4. kemi.is \[kemi.is\]](#)
- [5. dawsonsgroup.com.au \[dawsonsgroup.com.au\]](#)
- [6. What Ppe And Environmental Controls Are Required For Corrosive Electrolytes? A Complete Safety Guide - Kintek Solution \[kindle-tech.com\]](#)
- [7. flinnsci.com \[flinnsci.com\]](#)
- [8. Your Guide to Back-to-School pH Safety Rules - Sensorex Liquid Analysis Technology \[sensorex.com\]](#)
- [9. chemistry.ucmerced.edu \[chemistry.ucmerced.edu\]](#)
- [10. Alkaline Substances: Storage, Transportation, and Recycling Guidelines \[utilvtorprom.com\]](#)
- [11. Chapter 7 - Management Procedures For Specific Waste Types \[ehs.cornell.edu\]](#)
- [12. youtube.com \[youtube.com\]](#)
- To cite this document: BenchChem. [Essential Safety Protocols for Handling High pH Solutions (pH 14)]. BenchChem, [2026]. [Online PDF]. Available at: [\[https://www.benchchem.com/product/b12387845/docs#essential-safety-protocols-for-handling-high-ph-solutions-ph-14\]](https://www.benchchem.com/product/b12387845/docs#essential-safety-protocols-for-handling-high-ph-solutions-ph-14)

Disclaimer & Data Validity:

The information provided in this document is for Research Use Only (RUO) and is strictly not intended for diagnostic or therapeutic procedures. While BenchChem strives to provide

accurate protocols, we make no warranties, express or implied, regarding the fitness of this product for every specific experimental setup.

Technical Support: The protocols provided are for reference purposes. Unsure if this reagent suits your experiment?

Need Industrial/Bulk Grade? [Request Custom Synthesis Quote](#)

BenchChem

Our mission is to be the trusted global source of essential and advanced chemicals, empowering scientists and researchers to drive progress in science and industry.

Contact

Address: 3281 E Guasti Rd

Ontario, CA 91761, United States

Phone: (601) 213-4426

Email: info@benchchem.com

[Contact our Ph.D. Support Team for a compatibility check](#)